



**OPERATING INSTRUCTIONS
AND PARTS LIST FOR
U075075
U100058
UNDERGROUND HOSE REELS**



FORM NO.: 1132-1002
REV:

IMPORTANT
**READ THIS MANUAL CAREFULLY BEFORE INSTALLING,
OPERATING, OR SERVICING THIS EQUIPMENT**

MODEL NUMBER SIGNIFICANCE

A coded model number found on the reel nameplate indicates parameters and characteristics of that particular hose reel. Use the following diagram to verify your reel.

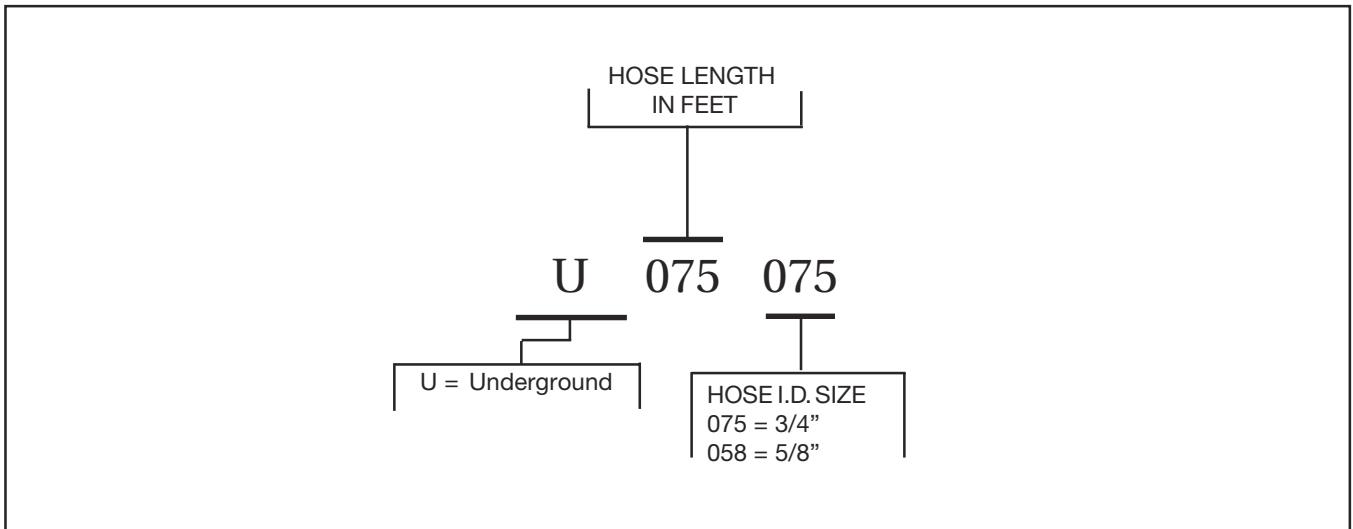

DIMENSIONAL DATA

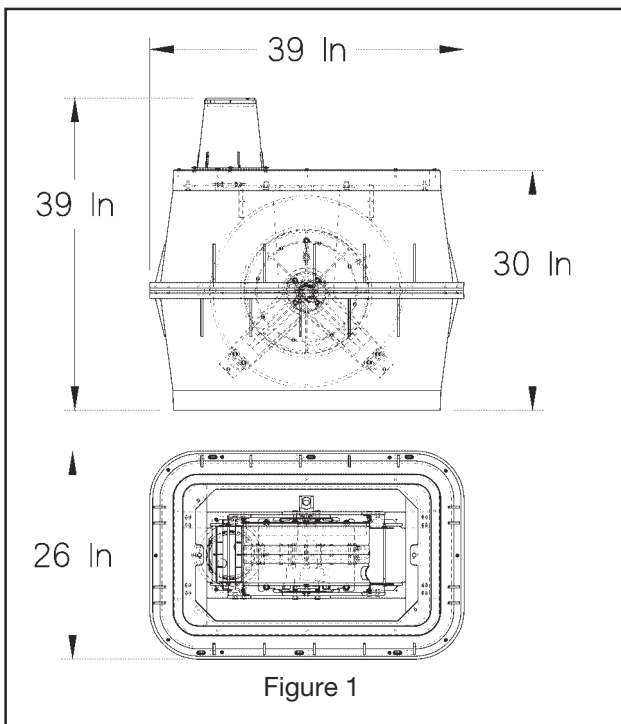

PERSONAL SAFETY

Personal injury and/or equipment damage may result if proper safety precautions are not observed.

- Ensure that reel is properly installed before connecting input and output hoses.
- Bleed water pressure from system before servicing reel.
- Before connecting reel to supply line, ensure that pressure does not exceed maximum working pressure rating of reel.
- Remember, even low pressure is very dangerous and can cause personal injury or death.
- Be aware of machinery and personnel in work area.
- If a leak occurs in the hose or reel, remove system pressure immediately.
- A high tension spring assembly is contained within the reel. Exercise extreme caution.
- Pull hose from reel by grasping the hose itself, not the control valve.
- If reel ceases to unwind or rewind, remove system pressure immediately. Do not pull or jerk on hose!
- Treat and respect the hose reel as any other piece of machinery, observing all common safety practices.
- Do not attempt to service unit through sump opening.
- Do not attempt to replace hose while unit is pressurized.

Installation and Operating Instructions for U075075 & U100058

Preparation

1. Determine a suitable location for the underground reel. An ideal location would have good soil drainage, and a level surface.
2. Remove the sod or landscaping, and dig a hole approximately 48" x 48" x 51" deep.
3. Place 12" of drainage stone on the bottom of the hole. See Figure 3.
Note: *Installing a drainage pipe is necessary in poorly drained soils. See Figure 4. The drainage pipe may be connected to an existing drainage system, a submerged dry well, or a culvert outlet. Note: Consult local construction codes and regulations before connecting to an existing drainage or storm sewer system.*
Caution: *The reel will be damaged if it becomes submerged in water. Adequate soil drainage must be provided.*
4. Add and level more drainage stone to bring the bottom of the hole to 39¼" from the top. Do not overfill the hole, it is easier to add more stone later if necessary.

Installation

5. Place reel unit in the hole and level. Compare the height of the riser opening with the finished grade, the top of the riser should be at grade level. See Figure 3. Add or remove stone to adjust the height of the riser to grade level.
6. Connect reel to the water line. See Figure 5. Use the supplied connection hose to connect the reel to water supply. Do not use rigid plumbing for the connection; this will void the warranty.
Warning: *Ensure that the supply line pressure does not exceed maximum working pressure of reel. Apply thread sealant to all pipe threaded connections. Do not over tighten connection.*
The top cover may be removed for access to the inlet hose of the reel. A hole may be cut in the reel case at any convenient point to route the hose or pipe. Seal the hole with silicon or similar sealant after the hose or pipe has been connected. As an alternative, the supply line may enter the case from the opening in the bottom if hard pipe is used. A shut off valve is recommended in the supply line in case the reel should need servicing. See Figure 5 for preferred plumbing diagram. See Figure 6 for alternate plumbing diagram for installations using existing irrigation systems.
Note: *The following parts are necessary to connect the reel to a 1½" PVC supply pipe; 1½" compression coupler, 1½" Threaded 3" nipple, 1½" brass gate valve, and 1½"x ¾" threaded reducer bushing.*
7. Check the system for leaks. If none, backfill the hole with drainage stone to the anti-flotation ring located at the center of the case. See Figure 3.
8. Replace the cover and backfill the rest of the hole with loam. Replace the sod or landscaping.

Operation

To access the hose, turn the cover until the notches in both the cover and riser line up. Pull up on the cover to remove. The hose may be pulled out to any desired length.

After use, pull or carry all of the hose back to the reel opening. The hose may damage grass or landscaping if allowed to retract unassisted. Feed the hose into the reel carefully to prevent the hose from piling up in the center of the reel. A slight side-to-side motion works best when the hose is being retracted.

Adjustment

Warning: *Use extreme caution; reel under tension. Avoid releasing latch mechanism.*

If necessary, adjust spring tension on reel by manually adding or removing wraps of hose from spool, one wrap at a time, until desired tension is obtained. Manually add wraps to increase tension. Remove wraps to decrease tension.

Caution: *When adding wraps of hose, add just enough wraps to achieve the desired tension without exceeding the drive spring winding capacity. Properly tensioned reels allow all hose to be freely removed from the spool. The drive spring will be damaged if it is over tensioned.*

Service Instructions

User servicing of the reel is limited to replacing the hose, without removing the reel from the ground. If other repairs are required, consult an authorized service person.

Hose Replacement

Shut off inlet water supply, and bleed pressure from hose. Pull all of the main hose out of the opening. The main hose is connected to a leader hose with a threaded fitting. Pull the leader hose out just until the threaded fitting is accessible, and the latch mechanism is engaged to prevent hose retraction. Remove the main hose by unthreading the connection. Attach the replacement hose to the leader hose. *Note: Thread sealant is **not** required on this connection only.* Be sure to use the hose end with tapered pipe threads for this connection. Tighten the threaded connection. Turn on water supply and check for leaks. If leaks are found, tighten threaded connection. Pull on the main hose to disengage the latch mechanism. The hose should retract normally. *Note: Replacement hoses may require some assistance in retraction for a few uses to wind onto the spool without piling or tangling.*

Reel Removal

Shut off inlet water supply, and bleed pressure from hose. Remove the sod and loam from the top cover of the reel vault. *Note: It is **not** necessary to remove the vault from the installation for repairs to the reel.* Remove the cover screws, and remove the cover. Remove the eight bolts from the cross rails. See Figure 2. Slide the reel to permit access to the inlet hose. Remove the inlet hose from the swivel. Pull reel vertically out of the vault. If necessary, the reel cover, loam, and sod may be replaced for aesthetic purposes.

Reel Replacement.

Remove sod, loam, and reel cover. Lower reel into vault, and slide to the side to allow access to the inlet hose. Connect the inlet hose using thread sealant. Position the reel so it is centered in the vault, and the mounting holes align. Secure with at least 4 bolts shown in Figure 2. *Note: The bolts shown in Figure 2 are primarily installed to prevent damage during shipment. These bolts are normally not required after installation.* Turn on the water supply to check for leaks. Bleed air out of hose. If leaks are found, tighten connections, or repair as necessary. After reel has been tested, replace the lid, using the existing screws. Replace the loam and sod.

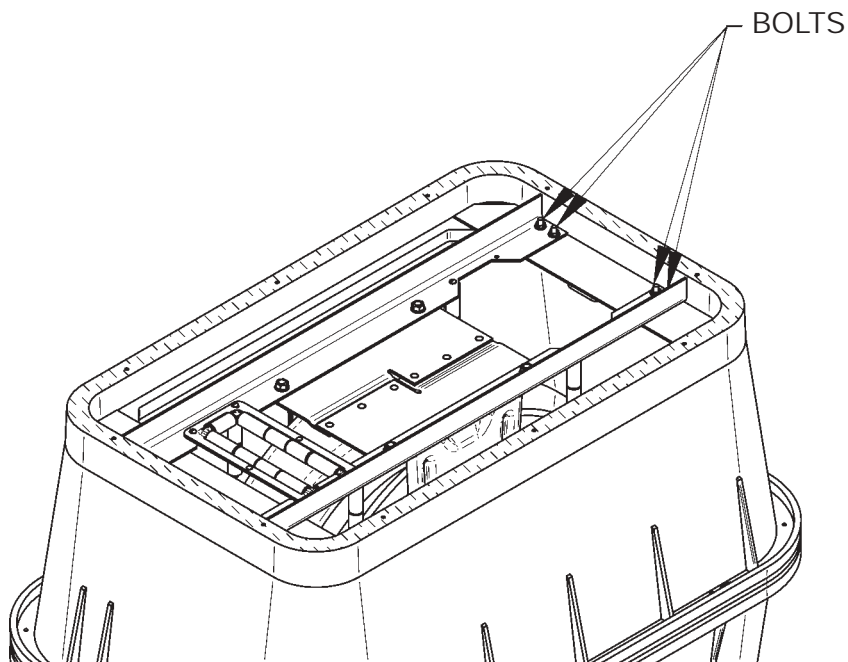

Figure 2

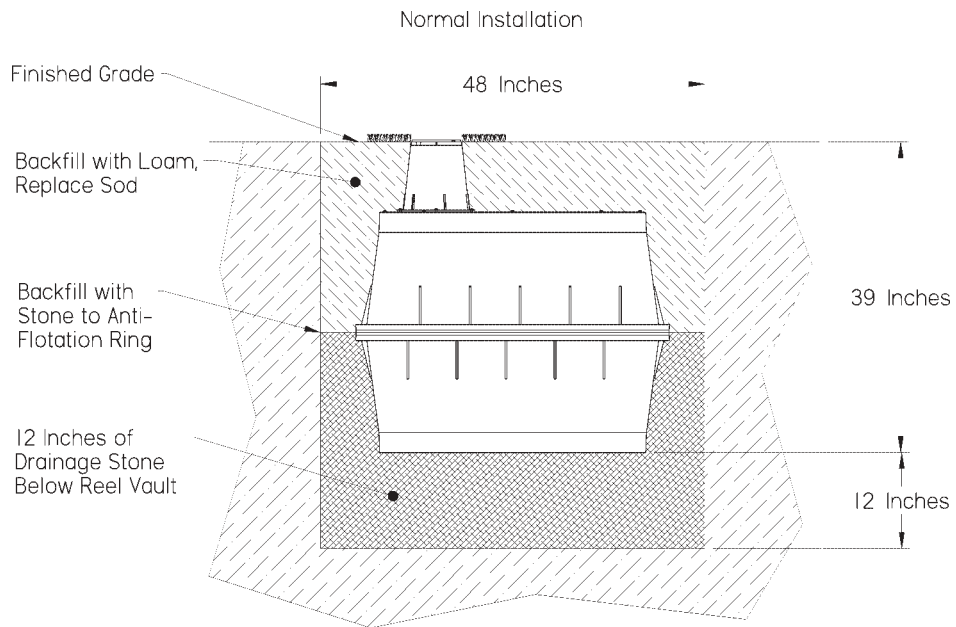

Figure 3

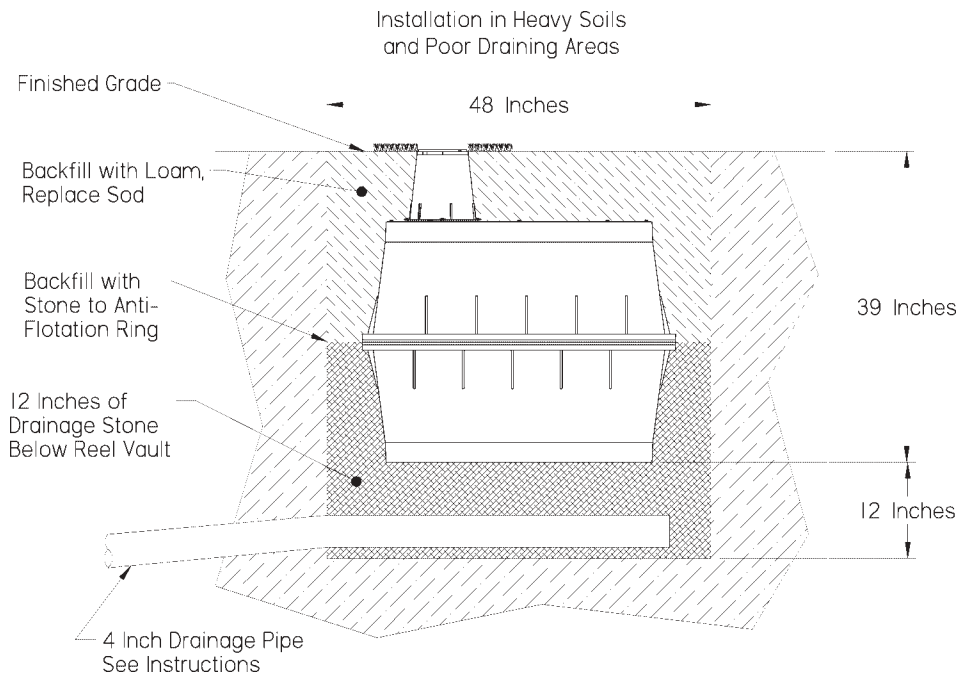

Figure 4

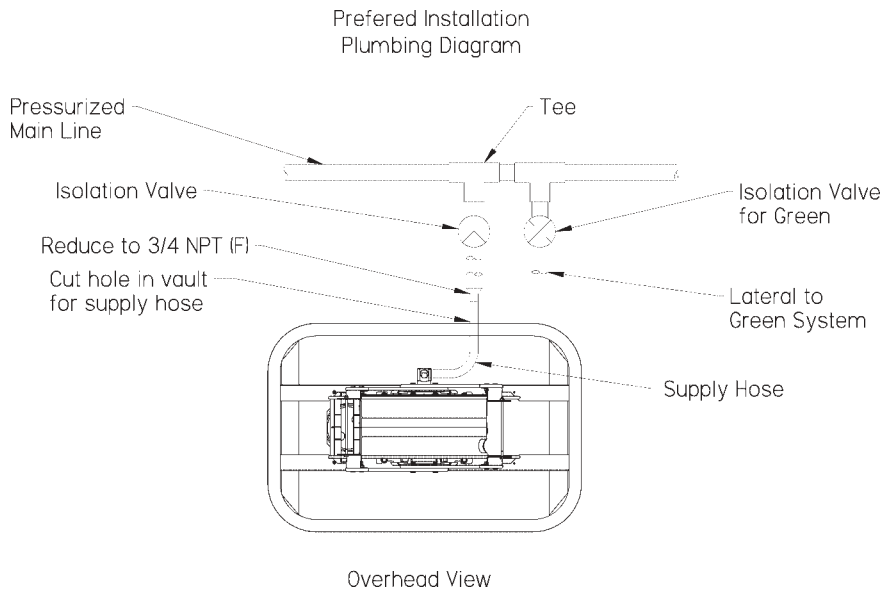

Figure 5

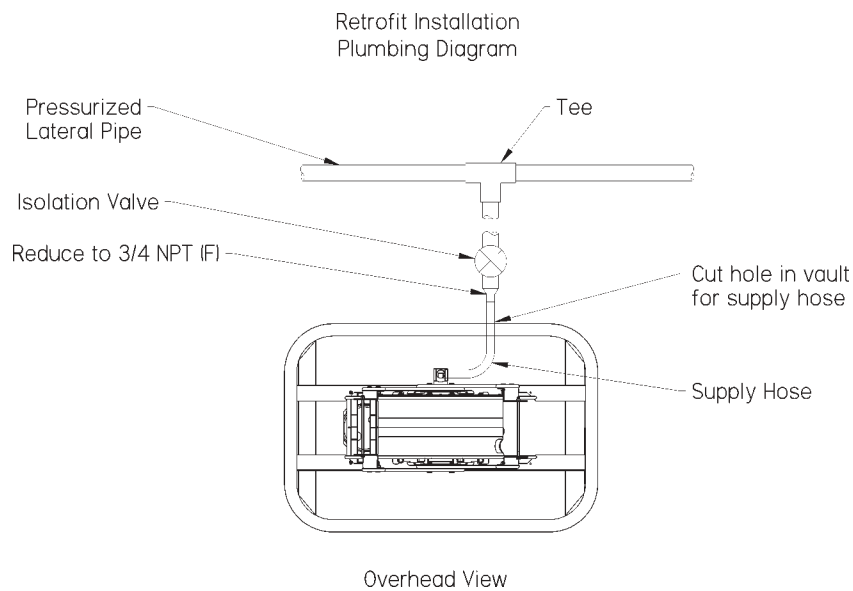

Figure 6

Item	Part No.	Description	Qty
1	300002	Machine Screw 10-32 x 1/2"	4
2	300039	Flat Washer, 5/16"	16
3	261427	Sump Riser	1
4	261487	Gasket Riser	1
5	S325-26	Hex Washer Screw, #10 x 1"	10
6	261486	Sump Cover	1
7	S20-121	Machine Screw 10-32 x 4 1/2"	4
8	S20-110	Machine Screw 10-32 x 7/8"	2
9	600738	Roller Bracket Ass'y	1
10	S281-4	Flange Nut, 1/4-20	8
11	S281-6	Flange Nut, 3/8-16	4
12	261428	Support Rail	2
13	S82-15	Nyloc Nut 10-32	10
14	117704	Guide Roller	8
15	261490	Sump Rail Support	2
16	S44-2	Hex Machine Bolt 3/8-16 x 5/8"	4
17	261425	Sump Body	2
18	S2-46	Hex Screw, 1/4-20 x 1 1/4"	8

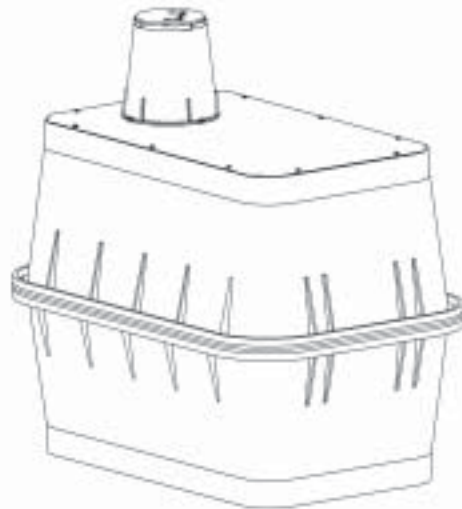

Figure 7

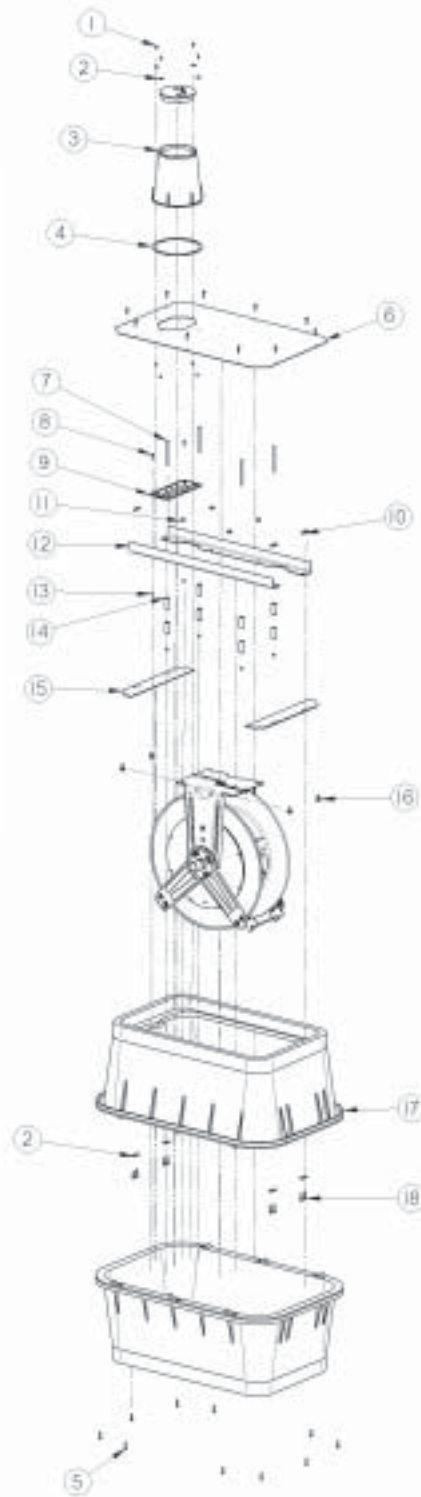

Figure 8

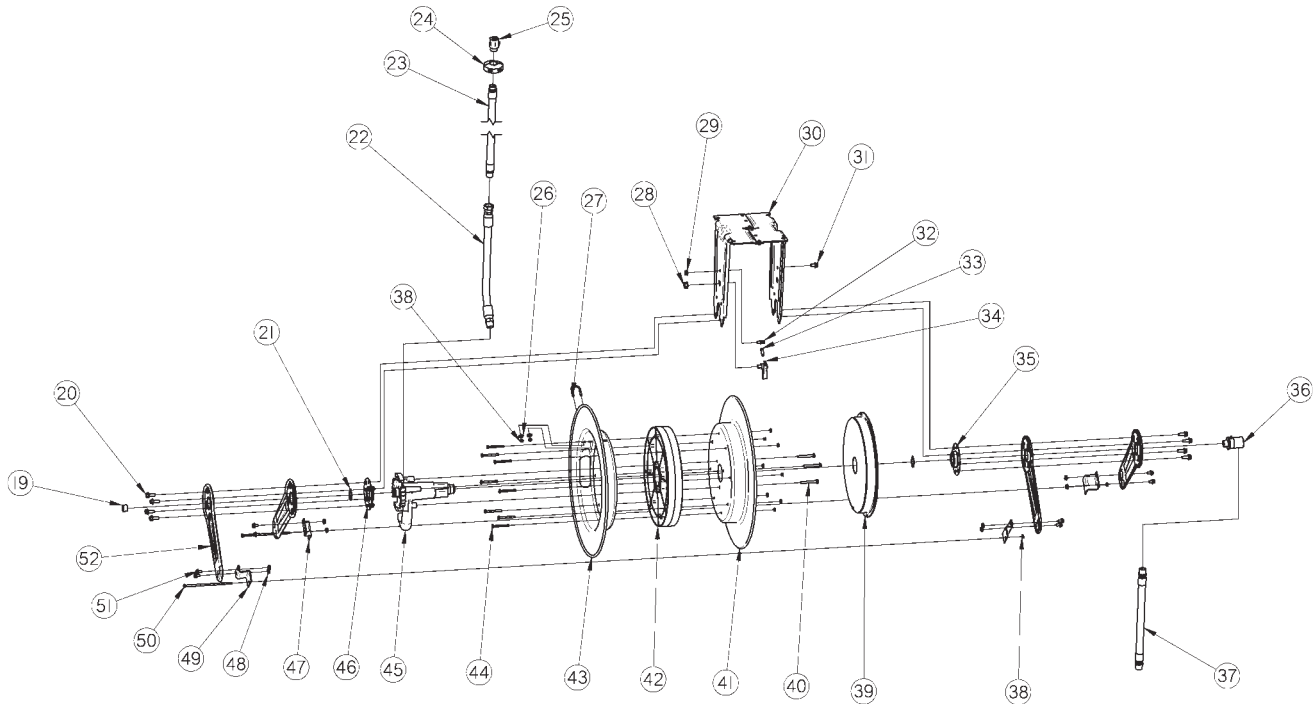

Figure 9

Item	Part No.	Description	Qty	Item	Part No.	Description	Qty
19	S183-54	Pipe Plug, 3/4"	1	36	602026	Swivel	1
20	S44-5	Hex Machine Bolt 3/8-16 x 1"	8	37	601034-3	Hose Assembly 3/4" x 3'	1
21	S140-34	Snap Ring	2	38	300070	Nyloc Nut 1/4-20	12
22	600717-4	Hose Assembly 3/4" x 4'	1	39	By Model	Spring and Case Assembly	1
23	By Model	Hose Assembly	1	40	S2-511	Hex Screw, 5/16-18 x 2 1/2"	3
24	By Model	Hose Bumper Assembly	1	41	261308	Sheave Springcase	1
25	261447	Garden Hose Valve	1	42	261393	Spool Spacer	1
26	300039	Flat Washer, 5/16"	2	43	261307	Sheave Hose Opening	1
27	5-117440	U-bolt	1	44	S2-411	Hex Screw, 1/4-20 x 2 1/2"	8
28	S280-8	Flange, Nut 1/2-20	1	45	261591-1	Flow Casting	1
29	S281-6	Flange, Nut 3/8-16	1	46	600651	Bearing Flange with Nutserts	1
30	602038	Base Assembly (D80000)	1	47	261488	Hose Guide	2
31	S44-2	Machine Screw 3/8-16 x 5/8"	1	48	300107	Hex Nut, 5/16-18	8
32	261351	Stud Latch Spring	1	49	261489	Hose Guide - Long	2
33	260067	Latch Spring	1	50	S2-425	Hex Screw, 1/4-20 x 7 1/2"	2
34	600774	Latch Pawl Assembly	1	51	S44-10	Hex Screw, 5/16-18 x 1/2"	8
35	600644	Bearing and Flange	1	52	261299	Guide Arm	4

Item	Description	Qty	U075075	U100058
23	Hose Ass'y	1	UH075075	UH100058
24	Hose Bumper Ass'y	1	A3-HR1004-3	600838
39	Spring & Case Ass'y	1	600820-3	600820-2