

ESC-1

Essential Irrigation Solutions Controller

The power of an advanced water-management tool in an easy-to-use package. The ESC-1 is a golf controller for the basic or sophisticated user. Four programs, a real-time calendar and the best customer satisfaction program in the industry help you conserve both water and money.

Features

- 12-hour watering duration for any or all stations to aid in drip compatibility
- Four independent programs with eight start times; each allow mixed irrigation applications in a single controller
- Two master valve terminals, one programmable by station, to provide better irrigation control
- Programs can overlap to maximize hydraulic efficiency and minimize watering time
- 365-day calendar with leap year intelligence for one-time date and time setting
- Event day off
- Programmable rain delay enables system to stay off for up to 99 days with auto-restart
- Upgradable to Golf Central Control
- Independent day cycle by program
- Water budget by program provides adjustments from 0-300% in 1% increments
- Programmable delay between stations provides time for water well recovery or slow closing valves
- Manual watering by station or program
- Non-volatile, 100-year memory holds program, date and time during power outages
- Diagnostic circuit breaker identifies electrical shorts, skips shorted station and continues watering remaining program
- Quick-connect terminal strip for fast installation in wall-mount model
- Universal remote ready—pre-installed connectors for addition of remote products in wall-mount model
- Heavy-duty transformer for simultaneous operation of up to nine 24 VAC, 7 VA solenoids
- Battery-programmable controller allows for programming prior to installation

- Available in two enclosures:
 - Powder-coated wall-mount steel cabinet
 - High-impact plastic pedestal

Operating Specifications

- Station timing: A, B, C & D—0 to 2 hours in one-minute increments; 2 to 12 hours in 10-minute increments
- Automatic starts: 32 starts total, eight per program per day
- Programming schedule: 1. ODD day watering, 2. EVEN day watering, 3. Variable day cycle from 1 to 99 days by program, 4. Custom day-of-the-week by program
- Test program: Variable 1 to 99 minutes
- Rain shutdown: Programmable 1 to 99 days

Electrical Specifications

- Input required: 117 VAC ± 10%, 60 Hz (International models: 220 VAC, 50 Hz)
- Output: 26.5 VAC, 3A
- Station load capacity: Up to two 24 VAC, 7 VA solenoid valves per station plus a master valve or pump start relay
- Diagnostic circuit breaker skips and indicates stations with overloaded circuits
- Power supply overload, backup fuse: 3A
- Battery backup: 9 VDC, NiCad rechargeable for programming under battery power and for maintaining active program-in-progress during a power outage
- Heavy-duty electrical surge protection for input and output

Dimensions

- Steel Wall-Mount
 - Width: 11⁵/₁₆" (28,7 cm)
 - Height: 11¹/₂" (29,2 cm)
 - Depth: 6¹/₂" (16,5 cm)
- Plastic Pedestal
 - Width: 17" (43,2 cm)
 - Height: 34³/₄" (88,0 cm)
 - Depth: 21" (53,4 cm)

Optional Features

- Pedestal Mount (PED-DD16)



How to Specify/Order:

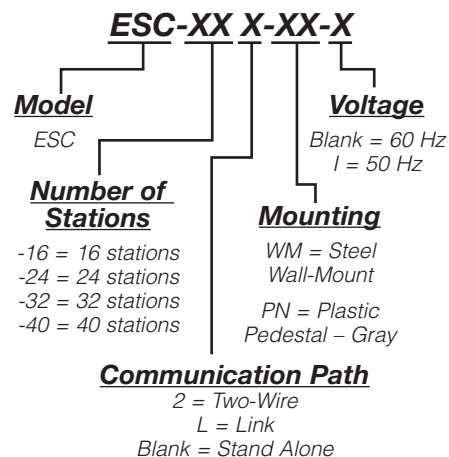



Specifications

The irrigation system controller shall be of a hybrid type that combines electro-mechanical and microprocessor-based circuitry capable of fully automatic and manual operation.

The controller shall operate on a 117 VAC \pm 10% power input and be capable of actuating up to two 24 VAC, 7 VA solenoid valves per station plus a master valve or pump start relay. The controller shall be capable of operating four stations plus the master valve simultaneously. Controller output shall be protected against severe electrical surge.

The controller shall have four separate irrigation programs (A, B, C & D) which can have different start times, watering days, day cycles and station timing. Each program shall have eight start times per day.

The controller shall have _____ stations, with each station capable of an operating time of 0 to 2 hours in one-minute increments and 2 to 12 hours in ten-minute increments. Controller station operation shall be of automatic sequential stacking to avoid overlapping operation unless programmed to overlap.

The controller shall have a 365-day calendar with day-of-the-month OFF feature. Programs will run on an ODD/EVEN day cycle, day-of-the-week ON/OFF cycle or in cycles from 1 to 99 days. In addition, the controller shall have a programmable rain shutdown from 1 to 99 days.

The controller shall have two master valve/remote pump start circuits for use with a master valve to pressurize the system when the irrigation cycle starts or to activate a remote pump start relay to run the pump during the irrigation cycle. One master valve/pump start circuit shall be programmable by station; the other shall function whenever a station is active.

The controller shall be capable of being operated manually at any time. A manual single station, a group of stations or a program can be selected to run for the programmed time without affecting the normal program. This controller shall be capable of running a variable system test program without affecting the normal program.

The controller shall be upgradable by use of a MAXI™ Interface Board.

The controller shall include a feature that allows the setting of a delay between station operation. This delay shall be set by program. This delay must be able to be set from zero seconds to nine hours.

The controller shall have an internal non-volatile memory which will retain the irrigation program and the programmed date and time for a minimum of 100 years without power. A 9 VDC rechargeable battery and recharging circuit shall also be included for counting down the program-in-progress during a power outage and shall allow programming of the controller when it is disconnected from the main power supply.

There shall be a station status indicator light and a master valve status indicator light. These lights will indicate station operation and circuit integrity.

The controller shall be available in a 16-gauge seamless steel cabinet suitable for wall-mounting or a high-impact plastic pedestal.

Rain Bird Corporation
6991 E. Southpoint Road
Tucson, AZ 85706, U.S.A.
Phone: (800) 984-2255 (520) 741-6100
Fax: (520) 741-6522
Email: rbgolf@rainbird.com

Rain Bird International, Inc.
145 North Grand Avenue
Glendora, CA 91741, U.S.A.
Phone: (626) 963-9311
Fax: (626) 963-4287

Technical Service and Support
(800) RAINBIRD (U.S. and Canada only)

www.rainbird.com

The Intelligent Use of Water™—Visit www.rainbird.com to learn more about our efforts.

© Registered Trademark of Rain Bird Corporation
© 2005 Rain Bird Corporation 12/05

D31697B