



# ***DECODER SYSTEM***

# ***MANUAL***

***DESIGN, INSTALLATION,  
OPERATION and TROUBLESHOOTING***

***Rain Bird Golf Division***  
***970 West Sierra Madre Avenue***  
***Azusa, CA 91702***  
***Phone: 800-984-2255 FAX: 800-446-5309***

This device complies with part 15 of the FCC Rules. Operation is subject to the following two conditions: (1) This device may not cause harmful interference, and (2) this device must accept any interference received, including interference that may cause undesired operation.

# TABLE OF CONTENTS

	<u>DESCRIPTION</u>	<u>PAGE</u>
Chapter <b>1</b>	<b>INTRODUCTION TO RAIN BIRD DECODER SYSTEM</b>	<b>1</b>
Chapter <b>2</b>	<b>DESIGN</b>	<b>3</b>
Chapter <b>3</b>	<b>INSTALLATION</b>	
Chapter <b>4</b>	<b>SURGE PROTECTION &amp; GROUNDING CENTRAL</b>	<b>57</b>
Chapter <b>5</b>	<b>SURGE PROTECTION &amp; GROUNDING DECODERS &amp; WIRE PATHS</b>	<b>68</b>
Chapter <b>6</b>	<b>PROGRAMMING</b>	<b>80</b>
Chapter <b>7</b>	<b>TROUBLESHOOTING</b>	<b>108</b>
	<b>ADDENDUM</b>	<b>145</b>



## **Introduction to Rain Bird Decoder Systems**

*Rain Bird Decoder Systems are Unique Irrigation Control Systems that Automate the Irrigation Process. Like all Rain Bird Systems, they offer Reliable Two-Way Communication. A Rain Bird Decoder Installation is Always Capable of being Expanded and Upgraded.*

The Rain Bird Decoder System provides dependable two-wire communication between the Rain Bird Central Control System and the Decoders in the field. This manual will provide a comprehensive overview of the design, installation, operation and troubleshooting of a Rain Bird Decoder System. This first chapter will provide a basic introduction to the Rain Bird Decoder Systems.

### **RAIN BIRD Decoder Irrigation Control System**

A Rain Bird Decoder System offers two-wire communication comparable to satellite systems. The difference is decoders, on the system, directly power the solenoids from the 2-wire path.

A Rain Bird Decoder System is programmed in the same way as any of the other Rain Bird Computerized Central Control Systems utilizing field Satellite controllers. The major exception is that instead of entering satellite and station identifications, decoder addresses are programmed into the software. Once programmed, the software communicates through the Rain Bird Decoder Interface (MDI unit) to the decoders in the field. This communication is carried through a low-voltage two-wire communication path to the numerous decoders located throughout the golf course. The decoders will directly activate the solenoids on the valve-in-head rotors and/or remote control valves. The decoders act on command from the Decoder Interface unit, or can be activated in the field using a Freedom System, communicating through

the Rain Bird Computerized Central Control System. The decoders respond to a four-digit or five-digit code. This code is used by the Central Software to address any of the decoders in the field along the two-wire path.

## **Applications of a Rain Bird Decoder System**

A Rain Bird Decoder system is an ideal irrigation control system for many applications. It is a system that provides flexible installation, almost unlimited expansion, and future compatibility for upgrading at some future date.

### **Architectural Elegance**

A Rain Bird Decoder System provides transparent automatic control of the irrigation system. There are no aboveground obstructions, making a decoder system ideal for an application in which the environmental elegance of the course is to remain undisturbed. Automatic irrigation control can be installed on a traditional Links style course without the obstruction of above ground enclosures.

### **Designed for Protection From the Elements**

The field components of a Rain Bird Decoder System are designed for underground burial, so they are all completely weatherproof. This makes a decoder system a perfect application for a golf course that is built in a flood plain. Anywhere that an automatic control system can be damaged by the elements of nature a decoder system can be buried without fear of damage.

### **Resistant to Vandal Damage**

Since all the decoders are underground, a decoder system is the solution to the problem of vandal damage on an irrigation system. On a golf course where vandalism is a concern, a decoder system allows all of the field components to be put underground and out of sight and out of reach of vandals.

### **Flexible Installation and Simple Expansion**

A Rain Bird Decoder System controls the field decoders with only a two-wire path running between all the decoders and the Central Control equipment. This two-wire path carries all the communication for the decoders as well as powering them for running the solenoids. Decoders can be added to the field in any type of layout desired. This flexible installation simplifies the installation process, and also allows the installation to be done in multiple steps. The decoder system can be installed in part of a golf course initially. When more holes are to be added, they can be connected to the rest of the system simply by splicing into the two-wire path on the existing layout. If a sprinkler head needs to be added in the future, simply connect a decoder to the existing two-wire path and add the address for this decoder to the software. This allows for installation of a Rain Bird Decoder System in multiple steps and also for simple expansion of the decoder system in the future.

## Design of a Rain Bird Decoder System

*The Design of your Rain Bird Decoder System Layout Is the Most Important Aspect of Ensuring that your Irrigation Control System Functions Correctly and is Easy to Maintain.*

The design of a Rain Bird Decoder system requires careful consideration to the layout of the decoder MAXI Two-Wire path\*. Since a decode system powers the electric solenoids through the two-wire path, the two-wire path must be able to provide enough voltage to power the solenoids. There are design specifications limiting the length of the two-wire *Critical Path*, the number of decoder addresses on a given two-wire path, and the number of simultaneous, active solenoids on a given two-wire path.

**TWO-WIRE PATH LAYOUT** – There are two types of configurations that can be used for the layout of the MAXI two-wire paths\*. The MAXI two-wire path\* can be installed as a **STAR** configuration, or as a **LOOP** configuration. The Line Termination Box will supply up to five separate two-wire paths, of the **STAR** configuration and up to two separate two-wire paths, of the **LOOP** configuration for decoders. It is preferable to separate the two-wire paths into multiple wire runs rather than install a single two-wire path throughout the golf course. These wire paths can be configured in either the **STAR** or **LOOP** layouts or a combination of the two types. Using the **STAR** configuration, the two-wire path can be branched throughout the course but is **NOT** looped back to the Line Termination Box. Using the **LOOP** configuration, the two-wire path is looped at the farthest reach of the layout, to provide for extended wire runs. For ease of troubleshooting, the **STAR** configuration is the recommended layout for the two-wire path.

\* Refer to the Addendum for complete specifications for the MAXI wire.

**STAR CONFIGURATION for TWO-WIRE PATH** – For normal installations with wire runs that are not excessively long, the recommended layout for the two-wire path is the **STAR** configuration. This is to facilitate ease of troubleshooting the system should it experience a wire fault or short. The distance of the farthest decoder from the LTB, LDI or SDI, measured along the two-wire path, is considered the **Critical Path** of the two-wire run for a **STAR** configuration. The maximum distance for the **Critical Path** is 1.5 miles for 16 AWG cable, 2.4 miles for 14 AWG cable, 3.8 miles for 12 AWG cable and 6.1 miles for 10AWG cable. For metric cable the maximum distance for the **Critical Path** is 3.0 Kilometers for 2.5 mm<sup>2</sup> cable. **Refer to TABLE 2.1** for complete data. A diagram of the **STAR** configuration layout is presented below.

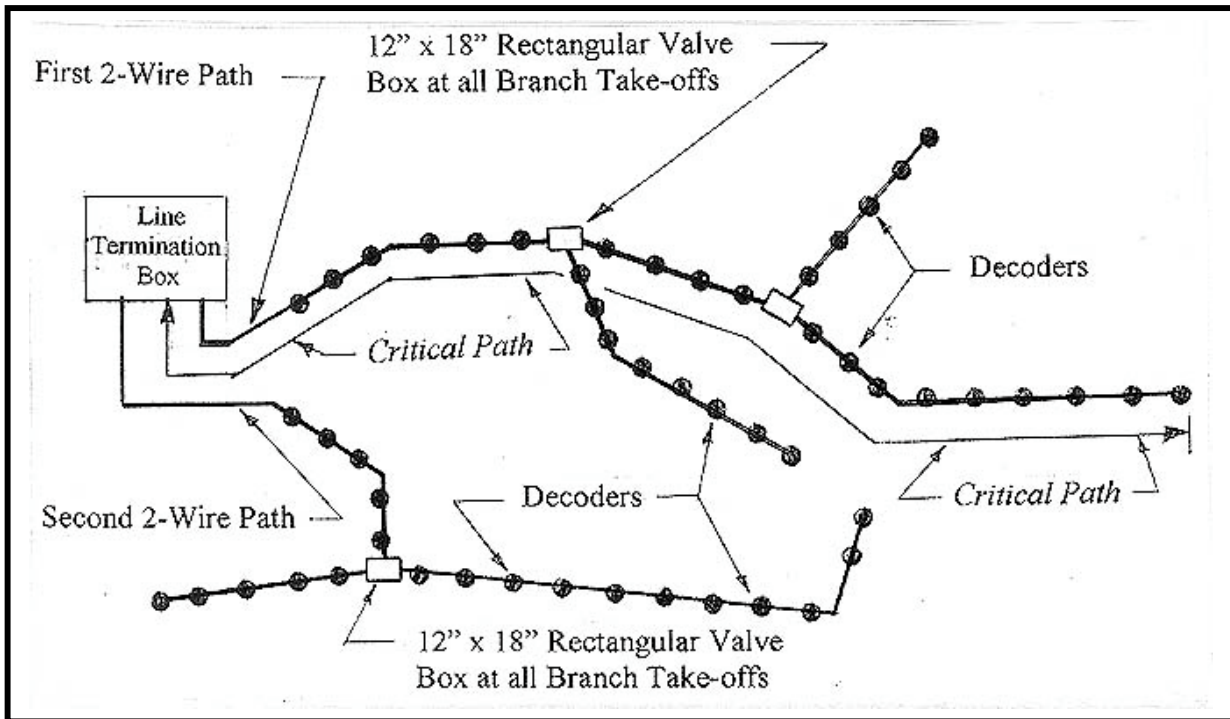

**FIGURE: 2.1**

MAXIMUM CRITICAL PATH LENGTHS FOR TWO-WIRE PATHS					
Nominal Wire Size	Ohms per 1000' Or Ohms per Km	MAX. LENGTH FOR CRITICAL PATH			
		LOOP		STAR	
		Km	Miles	Km	Miles
2.5 mm <sup>2</sup>	15.0 Ohms/Km	12.0	7.5	3.0	1.8
*16 AWG	4.09 Ohms/1000'	9.6	6.0	2.4	1.5
14 AWG	2.58 Ohms/1000'	15.2	9.6	3.8	2.4
12 AWG	1.62 Ohms/1000'	24.4	15.2	6.1	3.8
10 AWG	1.02 Ohms/1000'	39.2	24.4	9.8	6.1

**TABLE: 2.1**

\* These sizes are not recommended due to insufficient physical strength of the wire.

**LOOP CONFIGURATION for TWO-WIRE PATH** – If the installation requires longer wire runs, than are possible with the *STAR* configuration, then a *LOOP* configuration may be used. A *LOOP* configuration requires looping back the two-wire path from the farthest reach back to the central location and connecting to a terminal in the Line Terminal Box. The main two-wire path can be looped, and any branch paths from the main two-wire path can also be looped, from the main line back to the main line. In a *LOOP* configuration, the *Critical Path* is the distance measured by following the two-wire path around the loop out to the farthest decoder and back to the central. The maximum distance for the *Critical Path*, for a *LOOP* configuration is 6.0 miles for 16 AWG cable, 9.6 miles for 14 AWG cable, 15.2 miles for 12 AWG cable and 24.4 miles for 10 AWG cable. For metric cable the maximum distance for the *Critical Path* is 12.0 Kilometers for 2.5 mm<sup>2</sup> cable. A diagram of the *LOOP* configuration layout is presented in Figure 2.2.

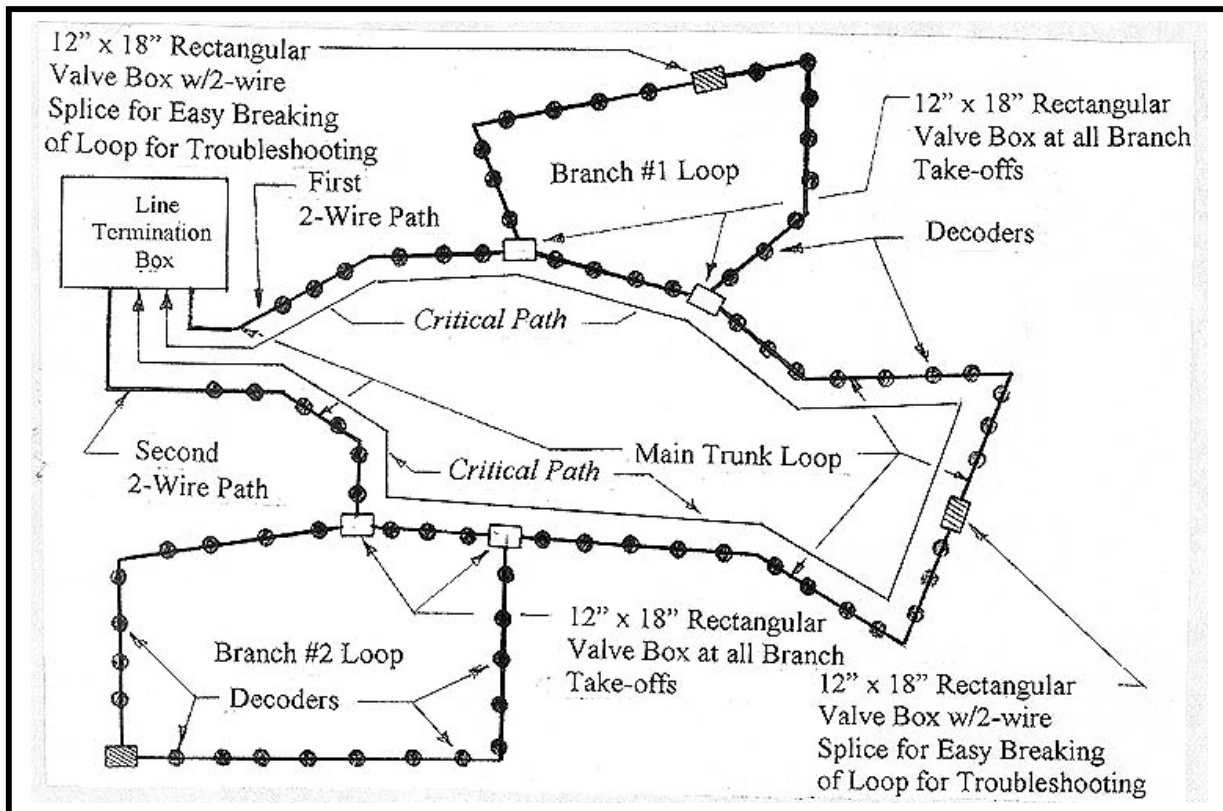

**FIGURE: 2.2**

**SPLICES IN TWO-WIRE PATH** – In all splicing locations of the two-wire path, for both the **STAR** configuration and the **LOOP** configuration, all wires shall be clearly marked with permanent type markings. The wire path should be marked to indicate the trunk wire coming from the central, the trunk wire continuing out from the splice location and the branch wire off of the trunk wire. For a **LOOP** configuration the branch marking should indicate branch **LOOP** number. Near the center of each **LOOP**, in a **LOOP** configuration layout, make a splice and place it in a 12" x 18" rectangular valve box. Provide three to four feet of excess wire in the valve box so that splice may be easily brought above ground for working with it. This is required for troubleshooting, so that the **LOOP** may be easily broken, otherwise it will be impossible to troubleshoot this **LOOP** to find a short, etc. this method of breaking the wire **LOOP** and the marking of all wires, at each splice location, are *absolutely necessary* to be able to successfully and easily troubleshoot the system. (Refer to **FIGURE; 2.3** below).

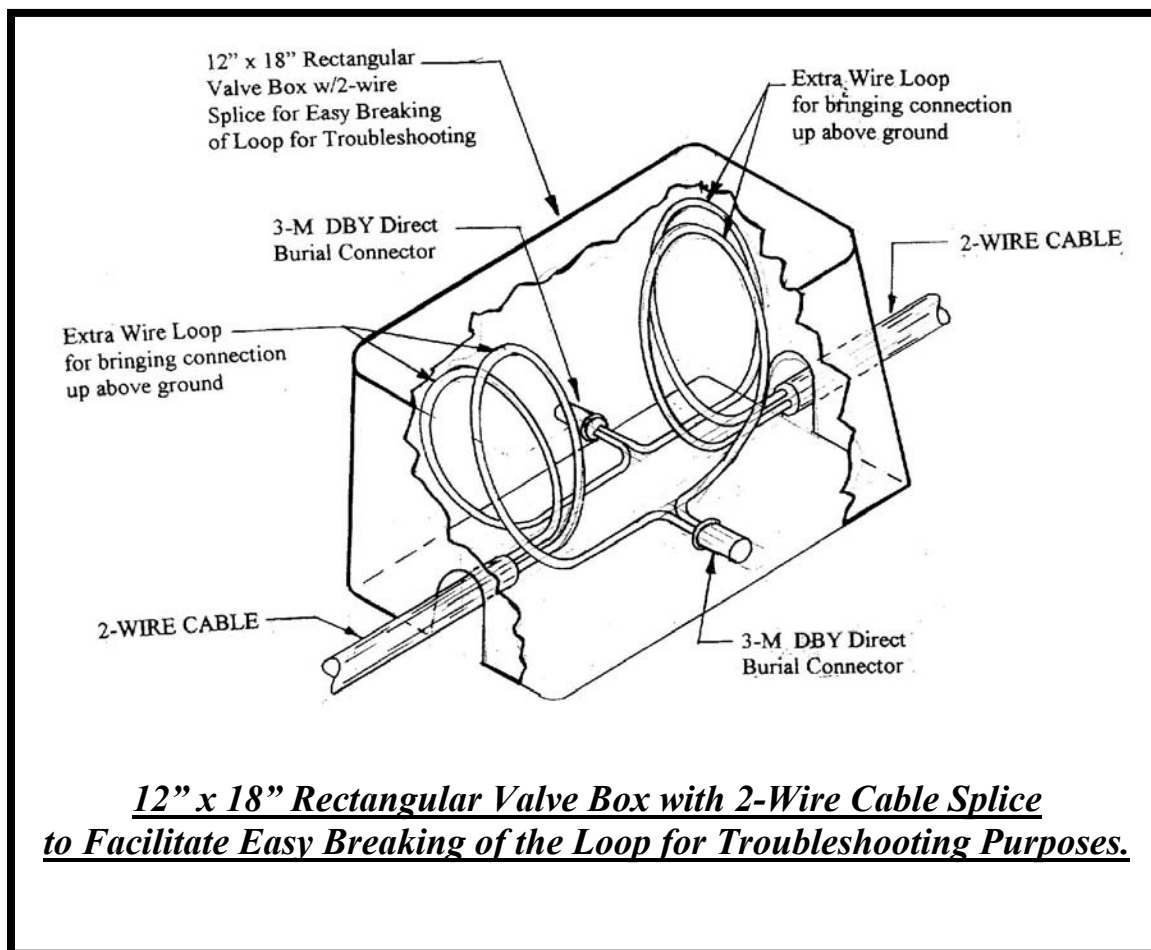

**FIGURE: 2.3**

**DECODER CHARACTERISTICS** - Decoders are electronic components fully sealed within a water-tight plastic enclosure that can be buried under-ground away from damage from vandals. They are an especially good choice for flood plains and in other areas where the risk of satellite damage is high.

Decoders replace satellites on centrally controlled irrigation systems. The decoders act as switching stations for digitized commands to sprinkler heads and/or remote control valves. Underground installation of the decoders and simple, low-cost wiring make decoders an aesthetically pleasing and economical option for reliable in-field control.

Full in-field control can be realized on the decoder systems by the use of a “plug-in” Field transmitting portable key pad or the integration of The Freedom system into the decoder system.

Advanced central control technology and simple wiring requirements of decoder systems have made decoders an ideal choice in the renovation of golf courses. It is now possible to operate satellites and decoders concurrently on the same central system. Decoder systems also lend themselves to easy expansion of the irrigation system requiring a minimal amount of wire and installation time.

**DECODER ADDRESSES** - The field line decoders, such as, FD-101, FD-102, FD-202, FD-401, FD-601 and the SD-210 Sensor decoder come furnished with a “FIXED” FACTORY pre-assigned, four or five-digit address code and are shipped to any particular installation on a random basis.

The address for newer decoders (decoders produced since 1998) is re-programmable, however, if this becomes necessary, by using the DPU-210, Decoder Programmer Unit available from Rain Bird.

**CHARACTERISTIC TABLE for VARIOUS DECODER MODELS**

<b>Decoder Model</b>	<b>Number of Addresses Per Decoder</b>	<b>Maximum Number of Solenoids Per Address</b>	<b>Maximum Addresses Operating At Once</b>	<b>Current Draw (mA) At Rest Per Decoder</b>
<b>FD-101</b>	<b>1</b>	<b>1</b>	<b>1</b>	<b>0.5 mA</b>
<b>FD-102</b>	<b>1</b>	<b>2</b>	<b>1</b>	<b>0.5 mA</b>
<b>FD-202</b>	<b>2</b>	<b>2</b>	<b>2</b>	<b>1.0 mA</b>
<b>FD-401*</b>	<b>4</b>	<b>1</b>	<b>4</b>	<b>1.0 mA</b>
<b>FD-601*</b>	<b>6</b>	<b>1</b>	<b>4</b>	<b>1.0 mA</b>

**TABLE: 2.2**

**Has LSP-1 Surge Arrestor built into it.**

## MODEL NUMBER NOMENCLATURE:

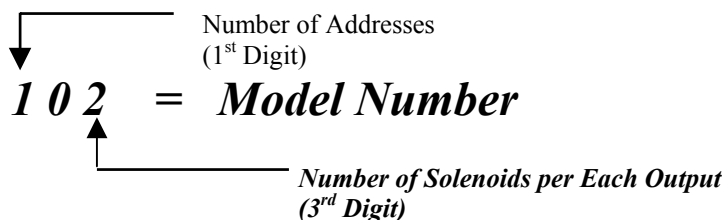

**SENSOR DECODER – Model SD-210:** Can be used either as a “SENSOR” Decoder or as a “PULSE” Decoder. Refer to the “Sensor Decoder” Section immediately following this chart.

**PUMP DECODER – Model PD-210:** Can be used to control a Pump Station or an Individual Pump. Refer to the “Pump Decoder” Section following that for the Sensor Decoder below.

## **SENSOR DECODER – Model SD-210:**

The **SENSOR DECODER** may be used either as a “*SENSOR*” Decoder or as a “*PULSE*” Decoder. The decoder is told by the central system what type of device it is when it makes contact with the system.

### ***PULSE DECODER :***

When used as a “*PULSE*” Decoder it is connected to a Pulse Flow Meter and sends the pulse back to the Central Control System computer through the MDI Interface Unit for action then to be taken by the Central System.

**FLOW METER** - Any type FLOW METER that has a “DRY” Contact Pulse (“Dry” contact pulse being a mechanical switch action only – NO voltage or transmitter frequency being involved) may be used with the “PULSE” Decoder.

**APPLICATION** - The Pulse Decoder is generally used for;

- 1) Registration of “System” or “Zone” flow,
- 2) Search and Elimination of excess flow or adjustment of system under flow, and
- 3) For instant flow measurement.

## **SENSOR DECODER:**

When used as a “**SENSOR**” Decoder it can be connected to any type of sensing device that has a mechanical “**DRY**” switch action for the threshold setting, either *an* “**OPEN**” switch at the threshold or a “**CLOSED**” switch at the threshold, and with **NO** voltage or frequency being

involved. The **SENSOR** status changes are transmitted through the MAXI Two-Wire communication path and the MDI Interface unit to the Central Control System Computer, where proper system action can take place.

**APPLICATION** - The most common application of the **SENSOR** Decoder is in conjunction with such devices, such as:

- 1) A Rain Sensing device.
- 2) A Moisture Sensing device.
- 3) A Pump Alarm device, etc.

These devices in conjunction with the sensor decoder are used to Start, Stop, and Pause, Re-adjust or Resume irrigation programs.

**CONSTRUCTION** - The **SENSOR** decoder is housed and “potted” in a plastic cylindrical case, similar to the FD-201 line decoder. The unit is completely “**POTTED**” green making it waterproof so that it may be direct buried if necessary. The sensor decoder has a four or five digit address code, just as the other field line decoders.

**WIRING** - The **SENSOR** Decoder has two (2) **BLUE** wires, which are to be connected to the MAXI Two-Wire communication path. The **BLACK** wire and the **RED** wire are to be connected to the sensor device for the purpose of receiving the sensing device input data. The two (2) **YELLOW** and **GREEN** wires are from the LSP-1 surge arrestor, which is included in the SD-210 sensor decoder unit. One of these wires should be connected to the sensing device case and the other wire shall be connected to a ground rod, as specified and required for the single LSP-1 surge arrestor .

**INPUT FUNCTION** - The input functions that the **SENSOR** Decoder is capable of, are:

- a) The Rain Bird Central System polls the Sensor Decoder for data when used as a pulse decoder it can record 0-200 pulses/minute.
- b) When used as 9-sensor decoder, the decoder records an open or closed switch action.

All functions (also input type) are programmable from the Rain Bird Central System as an integral part of the sensor installation.

## **PUMP DECODER - Model PD-210:**

The PD-210 PUMP Decoder can be used to control an entire Pump Station, an Individual Pump and/or a Booster Pump.

The PD-210 Pump Decoder has a selector switch, which allows it to be set to respond to one of six (6) possible address codes. Thus as many as up to six (6) PD-210 Pump Decoders may be used on any given system, whether they are controlling Pump Stations, Individual Pumps, Booster Pumps or any combination of these. The selectable address codes are as follows:

<u>SELECTOR SETTING</u>		<u>ADDRESS CODE</u>		<u>SELECTOR SETTING</u>		<u>ADDRESS CODE</u>
P1	=	284		P4	=	292
P2	=	286		P5	=	293
P3	=	287		P6	=	295

**OUTPUT** - The Pump Decoder only furnishes a “Dry Switch Closure” (no voltage output) and capable of handling up to 240 Volts with a Maximum Current Capacity of 8 AMPS.

**CURRENT DRAW** - The Pump Decoder, when in the Idle state (not Activated) has a current draw of less than 0.5mA.

**HOLDING COIL** - The HOLDING COIL of the Pump Motor Starter can be for any operating voltage up to 240Volts and with a maximum current draw of 8 Amps. The power supply for operation of the holding coil must come from some power source, as the Pump Decoder furnishes NO POWER but only provides a “Dry Switch” closure.

The connection of the PD-210 PUMP Decoder into the Control System shall be as shown in the diagram below – **Refer to FIGURE: 2.4 on the next page.**



**DECODER DESIGN PARAMETERS** – In addition to the limitations that govern the length of the two-wire *Critical Path* (refer to **TABLE 2.1**), there are guidelines to follow for the maximum number of decoder addresses that can be placed on a given two-wire path, and the number of “ACTIVE” solenoids that can operate simultaneously on a given two-wire path. The limitations are based on the voltage drop through the *Critical Path* of the wire run. The maximum allowable voltage drop is **9 VOLTS**. In order to maintain the ability to provide power to the decoders at the furthest extents of the two-wire path, the resistance of the wire path must **NOT** be greater than **33Ω (OHMS) TOTAL** for all wire in the *Critical Path*. By sizing the two-wire path and limiting the wire run distance according to **TABLE: 2.1** (displayed on previous pages) the resistance of the two-wire path will not exceed **33Ω**. The actual resistance can be calculated using the resistance’s found in **TABLE: 2.3** (below).

**RESISTANCE IN OHMS ( $\Omega$ )**  
*for*  
**VARIOUS SIZES OF MAXI TWO-WIRE PATH CABLE**  
*for ANNEALED COPPER WIRE*

<b>Nominal Wire Size</b>	<b>Wire Type (UF)</b>	<b>Type of Insulation</b>	<b>Resistance in Ohms at 77° F</b>
<b>Size AWG</b>		<b>Thickness In Inches</b>	<b>Ohms Per 1000'</b>
<b>16 AWG</b>	<b>Solid</b>	<b>4/64</b>	<b>4.09</b>
<b>14 AWG</b>	<b>Solid</b>	<b>4/64</b>	<b>2.58</b>
<b>12 AWG</b>	<b>Solid</b>	<b>4/64</b>	<b>1.62</b>
<b>10 AWG</b>	<b>Solid</b>	<b>4/64</b>	<b>1.02</b>
<b>METRIC WIRE SIZE DATA</b>			
<b>Wire Size</b>	<b>Wire Type</b>	<b>Thickness In Millimeters</b>	<b>Resistance in Ohms at 25° C</b>
<b>2.0 mm<sup>2</sup></b>	<b>Solid</b>	<b>0.7 mm</b>	<b>19/Km</b>
<b>2.5 mm<sup>2</sup></b>	<b>Solid</b>	<b>0.7 mm</b>	<b>15/Km</b>
<b>3.0 mm<sup>2</sup></b>	<b>Solid</b>	<b>0.7 mm</b>	<b>13/Km</b>
<b>3.5 mm<sup>2</sup></b>	<b>Solid</b>	<b>0.7 mm</b>	<b>10/Km</b>
<b>4.0 mm<sup>2</sup></b>	<b>Solid</b>	<b>0.7 mm</b>	<b>8/Km</b>

**TABLE: 2.3**

**DESIGN CRITERIA** – For any given two-wire path the following criteria must be adhered to, as shown in **TABLE: 2.4** below.

CONDITION	CIRRUS	NIMBUS II	NIMBUS	STRATUS II	STRATUS & SDC-1	STRATUS LT
Ohms Total for Critical Path Calculation	33 Ohms	33 Ohms	33 Ohms	33 Ohms	33 Ohms	33 Ohms
Max Number of Addresses per Wire Path	250	250	250	250	250	200
Max Number of Addresses per MDI / LDI	500	500	500	500	500	200
Max Number of Addresses per SDI	500	500	500	500	500	200
Max Number of “ACTIVE” Solenoid per Wire Path	20	20	20	20	20	20
Interface Unit	LDI/MDI	LDI/MDI	LDI/MDI	LDI/MDI	LDI/MDI	SDI
Max Number of “Active Solenoids per Interface**	40	40	40	30*	20*	15
Current Draw At Rest (mA)						
FD-101	0.5 mA	0.5 mA	0.5 mA	0.5 mA	0.5 mA	0.5 mA
FD-102	0.5 mA	0.5 mA	0.5 mA	0.5 mA	0.5 mA	0.5 mA
FD-202	1.0 mA	1.0 mA	1.0 mA	1.0 mA	1.0 mA	1.0 mA
FD-401	1.0 mA	1.0 mA	1.0 mA	1.0 mA	1.0 mA	1.0 mA
FD-601	1.0 mA	1.0 mA	1.0 mA	1.0 mA	1.0 mA	1.0 mA
“ACTIVE” Solenoid Current Draw (mA)						
Golf (Green Coil)	20 mA	20 mA	20 mA	20 mA	20 mA	20 mA
“B” (White Wires)	25 mA	25 mA	25 mA	25 mA	25 mA	25 mA
“DV” (Black Wires)	15 mA	15 mA	15 mA	15 mA	15 mA	15 mA
Hybrid System Max Number of Interfaces per System	4	3	N/A	2	N/A	N/A

**TABLE: 2.4**

**\* Software Limitation and Not an MDI Limitation.**

\*\* This number of decoders, on a large system with long wire runs, may reduce the number of ACTIVE decoders that you will be able to operate at one time before the Interface maximum current draw is exceeded and the Interface **“SHUTS-DOWN”** (disconnects from the field wiring).

**CALCULATE VOLTAGE DROP** – The voltage drop can be calculated using the known resistance of the wire in the Two-Wire path and the cumulative non-active current draw for all the decoders along the two-wire path, the cumulative current draw for all the “active” solenoids on the two-wire path and allowing an additional 30 mA draw for the MDI Lights and SUP-210 surge arrestor are activated.

The calculation can be made using the following formula:

$$( I \times R ) / 2 = V$$

Where: **I** is current in **AMPS (A)**  
**R** is resistance in **OHMS (Ω)**  
**V** is Voltage in **VOLTS (V)**

**GIVEN:**

The MDI/LDI (Interface Unit) “*Shuts Down*” at a current draw of **1100 mA**.  
 Use 1000 mA for design purposes! \*

The SDI (Interface Unit) “*Shuts Down*” at a current draw of **500 mA**.  
 Use 450 mA for design purposes! \*

\* To allow some safety factor, to handle small “leakage to ground” of current along the Two-Wire path, which is bound to happen due to poor splices, small nicks in the insulation, etc. use 1000 mA for design purposes.

Allow 30 mA for the MDI Lights & SUP-210 surge arrestor when active.

<b><u>Therefore:</u></b>	<b><i>MDI Lights &amp; SUP-210 surge arrestor</i></b>	<b>=</b>	<b>30 mA</b>
	<b><i>340 (Inactive) Decoders</i></b>	<b>=</b>	<b>170 mA</b>
	<b><i>40 (Active) Solenoids</i></b>	<b>=</b>	<b>800 mA</b>
			<b>1000 mA</b>
	<b>“I”</b>	<b>=</b>	<b>Total =</b>

**BASIC DATA:** - The basic data for a Decoder System is as follows:

- 500 Max.<sup>2</sup>** = Decoder (Addresses) per MDI/LDI Interface Unit.
- 250 Max.** = Decoder (Addresses) per Two-Wire Path.
- 40 Max.** = Active Solenoids per MDI Unit (with 20 mA current draw – each).
- 20 Max.** = Active Solenoids per Two-Wire Path (with 20 mA current draw - each).
- 9 Volts** = Maximum Voltage Drop Allowable per Two-Wire Path.
- 30 mA (total)**= for MDI Lights and SUP-210 when activated.

The LDI uses only 15 mA for the lights as it has a built in SUP-210 that draws no current.

0.5 mA Ea. = for Inactive Decoder (FD-210/FD-102 decoders).

1.0 mA Ea. = for Inactive Decoder (FD-410/FD-202; FD-401 & FD-610/FD-601 decoders).

15 mA Ea. = for Active "DV" Solenoid Coil with Black Wires.

20 mA Ea. = for Active "GOLF" Solenoid Coil (Green Coil).

25 mA Ea. = for Active "B" Solenoid Coil with White Wires.

230 Maximum Inactive Decoders (Addresses) per Two-Wire Path. (250 minus 20 active)

20 Maximum Active Solenoid Coils per Two-Wire Path.

<sup>2</sup> Although the MDI can handle a maximum of 500 decoders (addresses) total – with any number over a total of 380 decoders (addresses) the number of active decoders that you will be able to operate at one time, will be reduced.

#### EXAMPLE CALCULATION

**Green Golf Coil @ 20 mA Current Draw**

MDI Lights & SUP-210 when activated = 30 mA

230 Inactive Decoders = 230 x 0.5 mA = 115 mA

20 Active Golf (Green) Solenoids x 20 mA = 400 mA

"I" = Total mA = 545 mA = .545 A

#14 AWG Cable Size for Two-Wire Path @ 2.58 Ω/1000 ft.

Critical Path Length = 2.4 Miles = 2.4 x 5280' = 12,672 Feet Total

"R" = 12.67(1000's of feet) x 2.58Ω/1000' = 32.68 Ω

SUBSTITUTE: (in basic formula)

$$V = I \times R / 2$$

$$V = \frac{.545A \times 32.68 \Omega}{2} = 8.90 \text{ Volts Drop}$$

**METRIC CALCULATION:**

**2.5 mm<sup>2</sup> Cable Size for Two-Wire Path @ 15 Ω/Km**  
**Critical Path Length = 2.2 Km**

$$\begin{aligned} \text{"R"} &= 2.2 \text{ Km} \times 15\Omega/\text{Km} = 33.0 \Omega \\ \text{"I"} &= .545 \text{ A} \end{aligned}$$

$$\mathbf{V = \frac{.545\text{A} \times 33 \Omega}{2} = 8.99 \text{ Volts Drop}}$$

**EXAMPLE CALCULATION**

***"B" Coil w/White Wires @ 25 mA Draw***

**MDI Lights & SUP-210 when activated = 30 mA**  
**230 Inactive Decoders = 230 x 0.5 mA = 115 mA**  
**20 Active Golf (Green) Solenoids x 25 mA = 500 mA**

$$\text{"I"} = \text{Total mA} = 645 \text{ mA} = .645 \text{ A}$$

**#14 AWG Cable Size for Two-Wire Path @ 2.58 Ω/1000 ft.**  
**Critical Path Length = 2.4 Miles = 2.4 x 5280' = 12,672 Feet Total**

$$\text{"R"} = 12.67(1000\text{'s of feet}) \times 2.58\Omega/1000' = 32.68 \Omega$$

**SUBSTITUTE:** (in basic formula)

$$\mathbf{V = I \times R / 2}$$

$$\mathbf{V = \frac{.645\text{A} \times 32.68 \Omega}{2} = 10.54 \text{ Volts Drop (Over 9 Volts)}}$$

**Under this condition you would NOT be able to operate 20 of the “B” type solenoid coils Simultaneously.**

The total current draw cannot exceed 545 mA. There is a current draw of 145 mA with the MDI Lights & SUP-210 and the 230 Inactive Decoders on the Two-Wire Path. Therefore;

545 mA total minus 145 mA = 400 mA allowable for the Active Solenoids

@ 25 mA per solenoid 400 mA divided by 25 mA =

**16 Solenoids Max. that can be operated Simultaneously.**

This can be checked as follows:

#14 AWG Cable Size for Two-Wire Path @ 2.58 Ω/1000 ft.  
Critical Path Length = 2.4 Miles = 2.4 x 5280' = 12,672 Feet Total

$$\text{“R”} = 12.67(1000\text{'s of feet}) \times 2.58\Omega/1000' = 32.68 \Omega$$

$$\text{“I”} = .545A$$

SUBSTITUTE: (in basic formula)

$$V = I \times R / 2$$

$$V = \frac{.545A \times 32.68 \Omega}{2} = 8.90 \text{ Volts Drop (Under 9 Volts)}$$

Under these conditions and using the “B” type solenoid – the maximum number of solenoids that may be operated simultaneously is **16**.

# SYSTEM EXAMPLE CALCULATIONS

## STAR TWO-WIRE PATH CONFIGURATION: -

### 18 HOLE COURSE

2 – TWO-WIRE PATHS IN STAR CONFIGURATION – One for front nine holes & one for back nine holes.

36 FD-410/FD-202 decoders – with 2 at each Green operating 2 Solenoids (Golf Coils – Green) each solenoid at 20 mA current draw.

18 FD-410/FD-202 decoders on each of the Two-Wire paths.

400 FD-210/FD-102 decoders on entire system.

200 FD-210/FD-102 decoders on each Two-Wire path.

10 FD-410/FD-202 decoders desired to operate at one time on a Two-Wire path.

(2 solenoids on each decoder equaling 20 solenoids total, which is the maximum that can operate simultaneously on a Two-Wire path.)

Critical Two-Wire path length = 2.2 Miles

Wire size is #14 AWG cable @ 2.58 Ω/1000'

### CALCULATION:

$$\begin{aligned} \text{"R"} &= 2.2 \text{ Mi.} \times 5280' / \text{Mi.} = 11,616 \text{ feet total length} \\ &= 2.58 \Omega / 1000' \times 11.626 \text{ (1000's of feet)} &= & 30.0 \Omega \end{aligned}$$

"I" = MDI Lights & SUP-210 when activated	=	30 mA
200 (Inactive FD-210/FD-102 @ 0.5 mA each) = 200 x 0.5 mA	=	100 mA
8 (Inactive FD-410/FD-202 @ 1.0 mA each) = 8 x 1.0 mA	=	8 mA
10 (Active FD-410/FD-202 w/2 coils each @ 20 mA per coil or 40 mA total for each decoder) = 10 x 40 mA	=	400 mA
<b>TOTAL</b>	=	<b>538 mA</b>

"I" = .538 A

$$V = \frac{I \times R}{2} = \frac{.538 \text{ A} \times 30.0 \Omega}{2} = 8.07 \text{ Volts Drop}$$



**L**

**LOOP TWO-WIRE PATH CONFIGURATION:** - In order to calculate the voltage loss for a “LOOP” type Two-Wire path you must first convert the LOOP system into an equivalent “STAR” type system for determining the Critical Path Length for the Two-Wire path. *Refer to FIGURE: 3.4 shown below.*

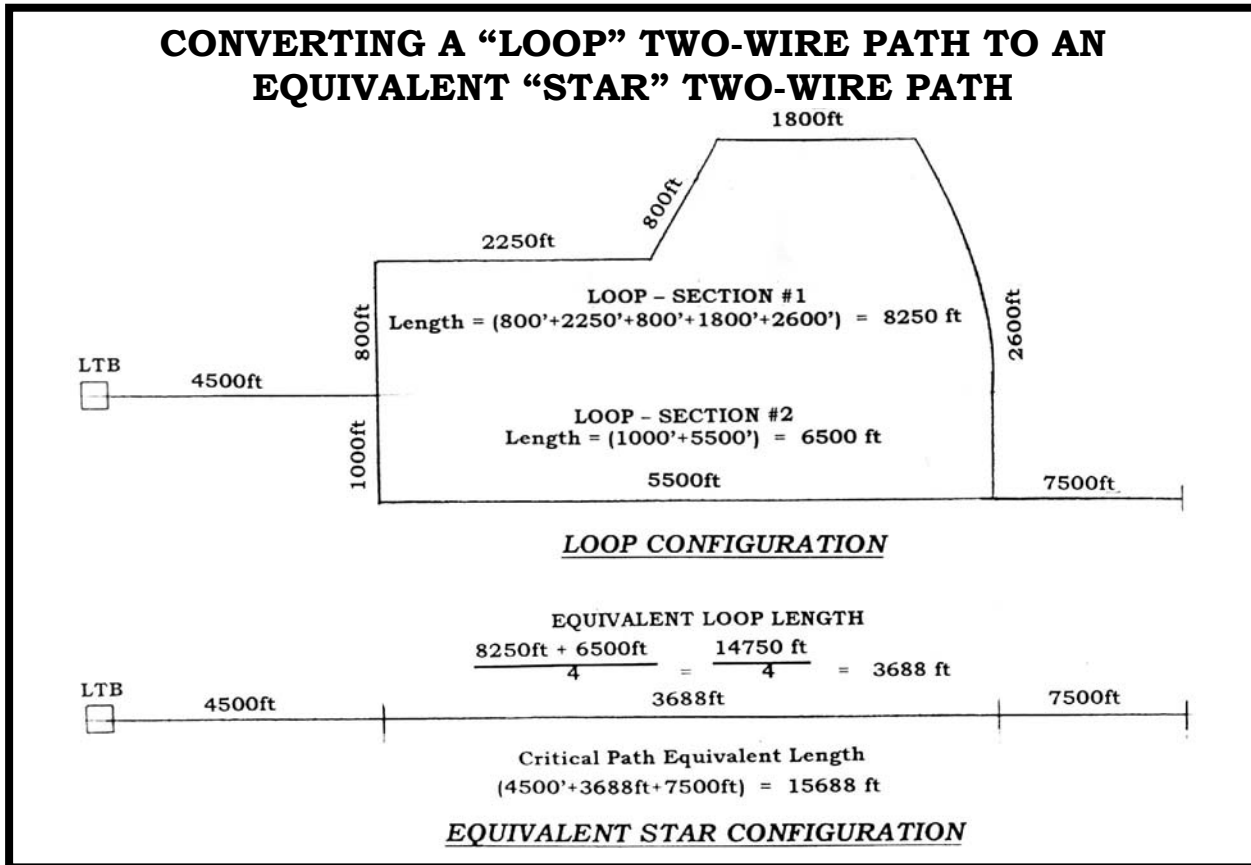

**FIGURE: 2.5**

**NOTE !**

In referring to **FIGURE: 2.5** above, you will note that the “*Equivalent Loop Length*” in the STAR configuration, is ¼ (one fourth) the total

Length of the LOOP in the LOOP configuration.

The length of Section #1 of the LOOP is = 800' + 2250' + 800' + 1800' + 2600' = **8250 feet.**

The length of Section #2 of the LOOP is = 1000' + 5500' = **6500 feet.**

Thus the “Equivalent Loop Length” of the LOOP is:

$$\frac{8250' + 6500'}{4} = \frac{14,750 \text{ ft}}{4} = 3688 \text{ feet}$$

The Critical Path Equivalent Length = 4500' + 3688' + 7500' = 15,688 feet

Wire size is #14 AWG cable @ 2.58 Ω/1000'

CALCULATION:

“R” = 15.7(1000’s of feet) x 2.58Ω/1000’ = 40.5 Ω

“I” = MDI Lights & SUP-210 when activated	=	30 mA
200 (Inactive FD-210/FD-102 @ 0.5 mA each) = 200 x 0.5 mA	=	100 mA
8 (Inactive FD-410/FD-202 @ 1.0 mA each) = 8 x 1.0 mA	=	8 mA
10 (Active FD-410/FD-202 w/2 coils each @ 20 mA per coil or 40 mA total for each decoder) = 10 x 40 mA	=	400 mA
<b>TOTAL</b>	<b>=</b>	<u><b>538 mA</b></u>

“I” = .538 A

$$V = \frac{I \times R}{2} = \frac{.538 \text{ A} \times 40.5 \Omega}{2} = 10.9 \text{ Volts Drop*}$$

**\*The voltage drop is in excess of 9 Volts, therefore the wire size needs to be increased or less solenoids operated in order to reduce the current draw and result in a lower voltage drop.**

To calculate the number of solenoids that could be operated simultaneously – keeping the same wire size . . .

9 Volts = Maximum Voltage Drop Allowable  
 “R” remains the same at 40.5Ω

Solve for the maximum current allowable under these conditions to stay at 9 Volts or less voltage drop.

$$I = \frac{V \times 2}{R} = \frac{9V \times 2}{40.5\Omega} = \frac{18}{40.5\Omega} = .494 A$$

MDI Lights & SUP-210 when activated	=	30 mA
200 (Inactive FD-210/FD-102 @ 0.5 mA each)	=	200 x 0.5 mA = 100 mA
8 (Inactive FD-410/FD-202 @ 1.0 mA each)	=	8 x 1.0 mA = <u>8 mA</u>
<b>Total</b>	=	<b>138 mA</b>

494 mA – 138 mA = 356 mA available

At 20 mA draw per solenoid - 356 mA divided by 20 mA = *16 solenoids maximum* can be operated simultaneously on this LOOP Two-Wire Path. This would limit the system to 8 FD-410/FD-202 decoders operating simultaneously

**NOTE !** *As long as the voltage drop is equal to or less than 9 volts, the two-wire path will be able to power all the decoders.*

**SECONDARY PATH WIRE RUN** – In addition to the parameters for sizing the *Primary Two-Wire Path Wire Run*, there are considerations for the *Secondary Path Wire Run*. The *Secondary Path Wire Run* is the wire path connecting the decoder output to the electric solenoid on the valve-in-head sprinklers or the remote control valves. The maximum total wire path length, from the decoder to the farthest solenoid, for different wire sizes is given in **TABLE: 2.5** below. For a single solenoid being connected to the decoder output, the length, from the decoder to the solenoid, may be taken directly from the table. When two (2) solenoids are being connected to the decoder output, the *total length* is the distance from the decoder to the first solenoid plus the distance again from the decoder to the second solenoid. (Refer to **FIGURE: 2.6** below).

**MAXIMUM WIRE RUN LENGTHS  
for  
SECONDARY PATH WIRE RUNS**

<b>Wire Size</b>	<b>Secondary Wire Run Lengths</b>	
	<b>METERS</b>	<b>FEET</b>
<b>1.5 mm<sup>2</sup></b>	<b>100</b>	<b>328</b>
<b>2.0 mm<sup>2</sup></b>	<b>133</b>	<b>436</b>
<b>2.5 mm<sup>2</sup></b>	<b>166</b>	<b>545</b>
<b>16 AWG</b>	<b>88</b>	<b>289</b>
<b>14 AWG</b>	<b>139</b>	<b>456</b>
<b>12 AWG</b>	<b>220</b>	<b>720</b>

**TABLE: 2.5**

For a single solenoid connected to the decoder output, the maximum length may be taken directly from the **TABLE: 2.5** above.

When two (2) solenoids are connected to the decoder output, the total maximum length shall be as calculated in the example in **FIGURE: 2.6** below.

**SECONDARY WIRE RUN CALCULATION**  
*for*  
**TWO SOLENOIDS CONNECTED to the DECODER**  
**OUTPUT**

**FIGURE: 2.6**

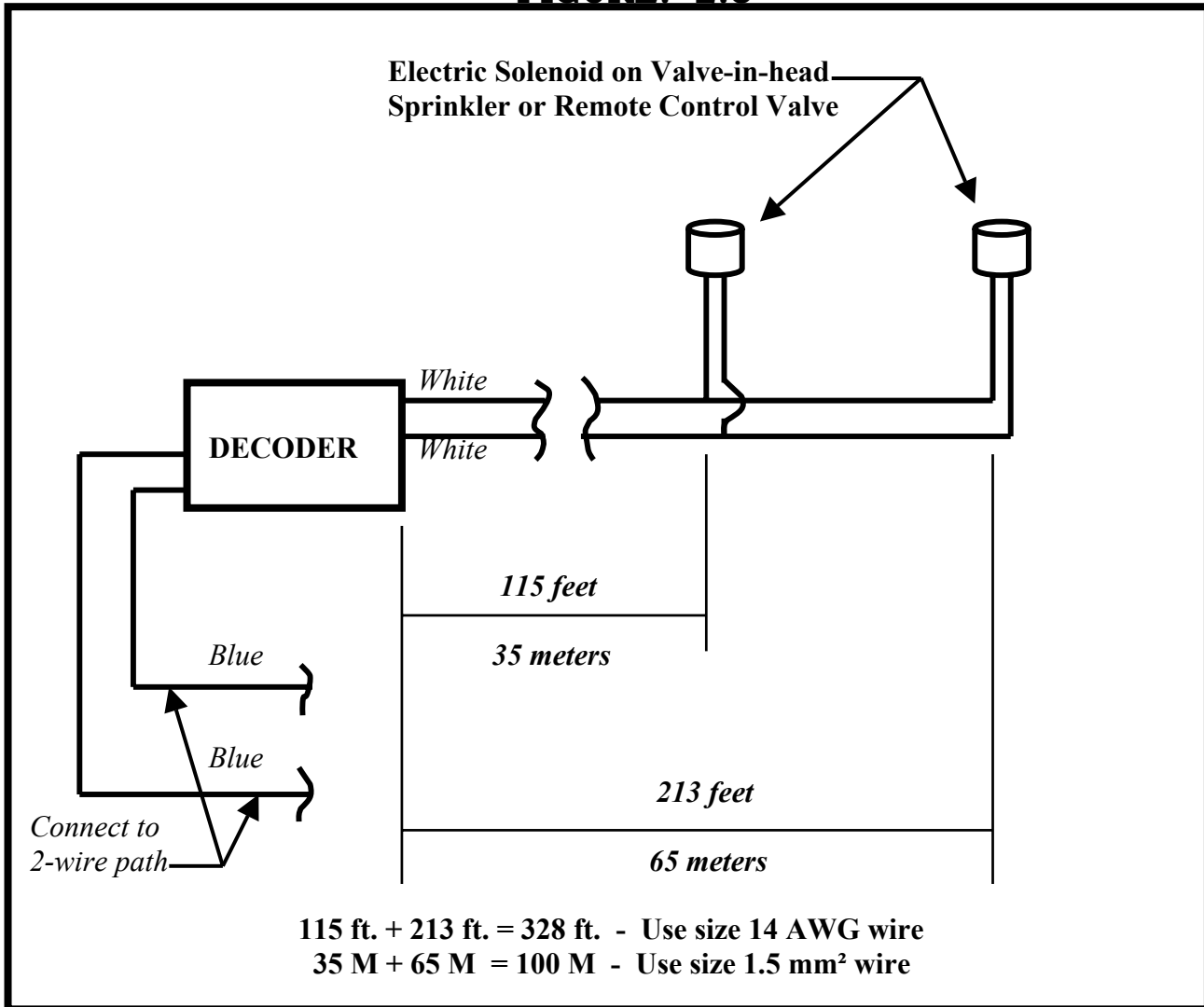

The maximum total length of the secondary wire path, when two (2) solenoids are connected to the decoder output, is defined as the sum of the wire path distance from the decoder to the first solenoid *plus* the wire path distance again from the decoder out to the second solenoid. This means that the section of the wire path that is powering both of the solenoids (the 115 feet/35 meter length in Figure: 2.6) is counted twice.

**FIELD SPECIFICATIONS** – Each two-wire path must **NOT** exceed the maximum wire run for its *Critical Path*. (*Refer to FIGURES – 2.1 & 2.2 for Critical Path measurement and refer to TABLE 2.1 for maximum Critical Path lengths.*) A maximum of 250 single address decoders (**FD-102**) may be connected on a given two-wire path. A maximum of 125 Multi-address decoders (**FD-202, FD-401, or FD-601**) may be connected on each two-wire path. Or any combination of *Single Address* decoders and *Multi-address* decoders may be combined on a given two-wire path as long as the **TOTAL Non-Active current draw** does not exceed **115 mA**. A maximum of 500- single address decoders (**FD-102**) may be connected to any individual MDI Interface Unit. A maximum of 250 Multi-address decoders (**FD-202, FD-401, or FD-601**) may be connected on any given MDI Interface Unit. Or any combination of *Single Address* decoders and *Multi-address* decoders may be combined on a given MDI Interface Unit as long as the **TOTAL Non-Active current draw** does not exceed **230 mA**. (*Refer to TABLE 2.4 for complete information*). The maximum number of “**ACTIVE**” solenoids on any given two-wire path is 20. The FD-102 decoders powering 2 solenoids each is considered as **TWO** “**ACTIVE**” **SOLENOIDS** even though using only **ONE** address. The maximum number of “**ACTIVE**” solenoids on any given MDI Interface Unit varies by **SYSTEM TYPE**. (*Refer to TABLE 2.4 for maximum number of solenoids for each type system.*)

It should be noted that the requirement is for a maximum number of **SINGLE ADDRESS DECODERS** and/or **MULTI ADDRESS DECODERS** and not JUST the number of Decoders. An FD-101 and FD-102 is **ONE** decoder address and thus a *Single Address Decoder*.. Likewise, the FD-202 is **TWO** decoder addresses, the FD-401 is **FOUR** decoder addresses and the FD-601 is **SIX** decoder addresses and are therefore *Multi Address Decoders*.

**CENTRAL SPECIFICATIONS** – The Rain Bird Decoder System may contain multiple two-wire paths – in fact it is ***STRONGLY RECOMMENDED*** that multiple two-wire paths be designed into the system rather than just one large two-wire path. The MINIMUM number of Two-Wire paths is dictated by the number of *Single Address Decoders* and *Multi Address Decoders* that you have on your system and the type of wire system; i.e. **STAR** or **LOOP** type two-wire path. (**Refer to TABLE 2.4 for further information.**) The decoders must be divided into separate two-wire paths according to the specification previously mentioned.

All of the decoders, on a decoder system, must have a unique four or five digit address code. These address codes are used by the Central Control system to control each decoder individually. For purposes of programming and daily operation of the system, each decoder is also given a specific “programming” name by the operator or programmer, which usually identifies the type area it is servicing and the location on the course. This is for ease of programming and daily operation, rather than try to remember the specific decoder’s four or five digit address code. The computer can then in turn send the specific four or five digit address code to the field for actual operation of the decoder.

## Installation of Decoders and Wiring for the System

*The Successful Installation of a Decoder System Requires Careful Adherence to Proper Installation Procedure, Especially in Making the wire splices.*

It is of the utmost importance that a Decoder system be installed properly since the entire system, once installed, will be underground and therefore not easy to access should any alterations or repairs be required. A system installed correctly will function trouble-free for many years to come. A system that is installed without heeding the installation guidelines will most likely require undue maintenance and troubleshooting, possible “down-time” and could result in expensive service and repair bills. In this chapter and succeeding chapters, important requirements for the correct installation of a Decoder system will be presented. Proper wiring methods, surge protection, and grounding requirements will be discussed. **The most important step in the installation of a decoder based irrigation system is the field and decoder wiring. It is definitely to the installer’s advantage to take extra care during the wiring phase of the project.**

It is recommended that all sections of these guidelines be read thoroughly before focusing on the sections that apply directly to the design being installed.

Terminology: **“Primary Path”** - Wiring from Line Termination Box to field decoders out to the farthestmost point from LTB.

Types of Primary Paths – **“Star”** and **“Looped”** configurations. (Looped is NOT recommended due to difficulty in troubleshooting the system.)

**“Critical Path”** – Longest distance, measured along the wire path, from the LTB out to the farthestmost decoder away from the LTB.

**“Branches”** or **“Branch Loops”** - Wires that “spur off” the Critical Path, to pick up decoders.

**“Secondary Path”** - The wire that extends from the decoder output to the solenoid(s) of the remote control valve or the valve-in-head sprinkler.

A Decoder system is relatively easy to install and set-up. Special attention must be paid to three areas in order for the system to function up to its maximum capabilities, these areas are:

- 1.** Installation of the two-wire communication path and most importantly the wire connections (splices).
- 2.** Proper installation of surge protection equipment and devices.
- 3.** Proper installation and maintenance of the grounding systems.

If these areas are properly installed, the system can be ensured of proper operation as well as limiting unnecessary damage to equipment due to voltage surges occurring on the system. Failure to provide proper protection and proper installation, in these areas, can result in costly service and repair bills for the golf course, as well as down time for the system, due to surge damage.

This chapter is presented in an effort to stress the need for proper installation and proper surge protection for the decoder system. The information is presented using two formats. One form is a set of detailed installation drawings that summarizes exactly what surge protection, wiring, and grounding is required and how it is to be installed.

The second is a written description of the installation procedures and surge devices required, as well as, the necessary grounding of these devices and/or the equipment.

## **GETTING STARTED WITH THE INSTALLATION**

**FIELD WIRING** - The first step is to become familiar with the wiring layout for the two-wire paths. The wiring for the two-wire paths is recommended to generally follow the piping of the system, as much as practical. It is also strongly recommended that the two-wire path wiring be laid out in a **“STAR”** or “branched” configuration, terminating in a number of dead ends. (*Refer to FIGURE: 2.1*) This is primarily for the ease of potential troubleshooting in the future. It is important that a **“LOOP”** configuration does NOT occur any where in the two-wire path unless the system has been specifically designed as a **“LOOP”** type system. (*Refer to FIGURE: 2.2*)

**CONTINGENCY WIRING** – It may be advisable to consider installing some “contingency” MAXI Two-Wire cable, which can allow a given area of the system to be electrically controlled from a different direction if a fault occurs on the primary communication path.

All two-wire cable designated as “**CONTINGENCY**” cable shall be installed with all ends disconnected. Wire ends shall be placed in 3-M type DBY or DBR electrical connectors and housed in a 10” Diameter round valve box, with cover and marked “ELECTRICAL”.

**COLOR CODED CABLE** – Each two-wire path shall have a differently colored outer jacket on the MAXI cable. All branches from the main trunk line (Critical Path) of the two-wire path shall also be of the **SAME** color outer jacket as that of the main trunk line of the two-wire path. It is extremely important **NOT** to mix cable colors on any given two-wire path, just as it is important that **EACH** two-wire path have its own different colored outer jacket on the cable and no two-wire paths with the same color cable. Color coding of the two-wire path cable can be an invaluable troubleshooting tool in the future.

## Installation of Wire

**WIRE INSTALLATION ON A NEW CONSTRUCTION** – When wire is being installed at the same time as new piping, it shall be laid on top of the 6” layer of clean back fill that covers the pipe. In rocky conditions the trench shall have a 6” layer of clean sand on the bottom of the trench before backfilling is started. If rocky back-fill is being used (which is **NOT** recommended), the wire shall have a 6” layer of sand on top of it, before backfilling is started. The wire shall have a minimum of 18” cover on it after backfilling is completed.

It is necessary to maintain consistency as to which side of the trench the wire is laid.

By so doing you reduce the risk of damaging the wire should it be necessary to dig in the area to repair a pipeline leak or break. For example; looking down a golf hole from the tee to the green, always lay the wire on the left side of the trench.

**FIGURE: 3.1**

*Refer to FIGURE: 3.1 at the right.*

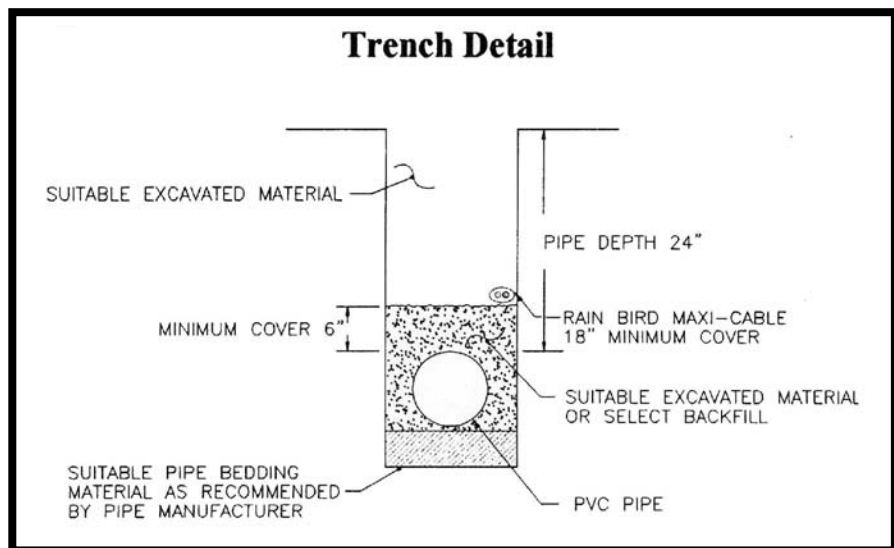

Where wire passes under roadways, cart paths, walls, or any other paved areas or where it may be attached to the under side of bridges, etc., it shall be installed in a minimum of a 2" size PVC Schedule 80 pipe conduit or a conduit that meets local codes.

**WIRE INSTALLATION ON AN EXISTING SYSTEM** – Where the two-wire cable is being installed on an existing system, the cable may be laid using a vibratory plow with a wire sleeve of sufficient size to prevent scoring of the outer jacket or putting friction on the outer jacket. ***It must never be "pulled" in.*** When the wire is laid with a vibratory plow – extra care must be taken to be sure the wire does NOT catch in the sleeve and cause the copper conductors in the cable to be stretched, which produces a weak spot and very subject to future fracture of the conductor. If the copper conductor is stretched too much an actual break may occur in the conductor within the insulation jacket and remain undetected at the time of installation. This, of course, can cause considerable time and labor to later "pin-point" the location of the conductor fracture and correct it.

## Making of Wire Splices

**WIRE SPLICES** – Wherever splices are made in the two-wire path or decoder wiring, they shall be placed in a valve box. The only exception to this is for decoders at Valve-in-Head sprinklers, where the decoders and wire splices may be direct buried, or unless other methods of installation are desired, such as; placing them in a small round valve box, in a pipe sleeve with cover, etc. This will be discussed further later in these guidelines. This means that **ALL** main trunk line splices and **ALL** branch take-off connections **MUST** be placed in a valve box. Valve box shall be a minimum of 10" in diameter with cover or a 12" x 18" rectangular type valve box with cover. Sufficient slack shall be left at each connection and splice to allow wire and connectors to be lifted a minimum of one foot (1'-0") above the finished grade level for ease of testing and troubleshooting of wire cable. **Refer to FIGURE: 3.2 below.**

### Typical Wire Splice in a Rectangular Valve Box

**FIGURE: 3.2**

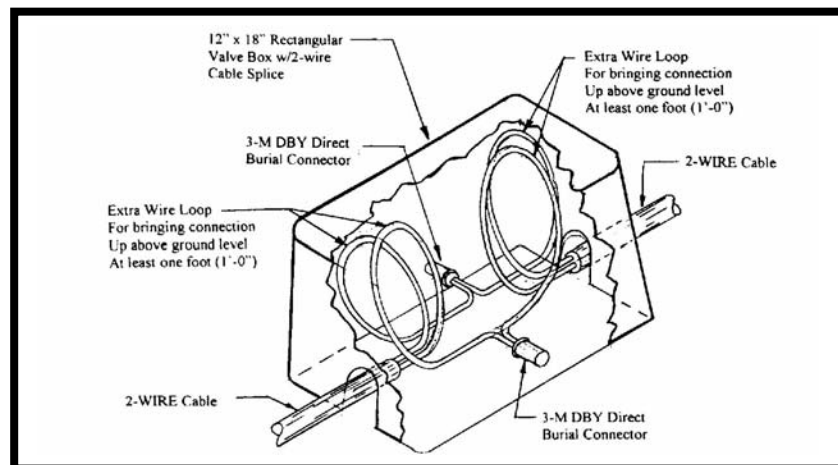

## Marking of Wire Splices

**WIRE SPLICE MARKING** – All wires in a valve box shall be permanently identified as to their routing direction or the holes they feed using a permanent marking pen and marking on the cable outer insulation jacket or using some other suitable permanent tag (metal, plastic, etc.) to identify the wire. *Refer to FIGURE: 3.3 below.*

**Be absolutely certain this step is not overlooked, as it can save time and frustration, should wire troubleshooting be necessary in the future.**

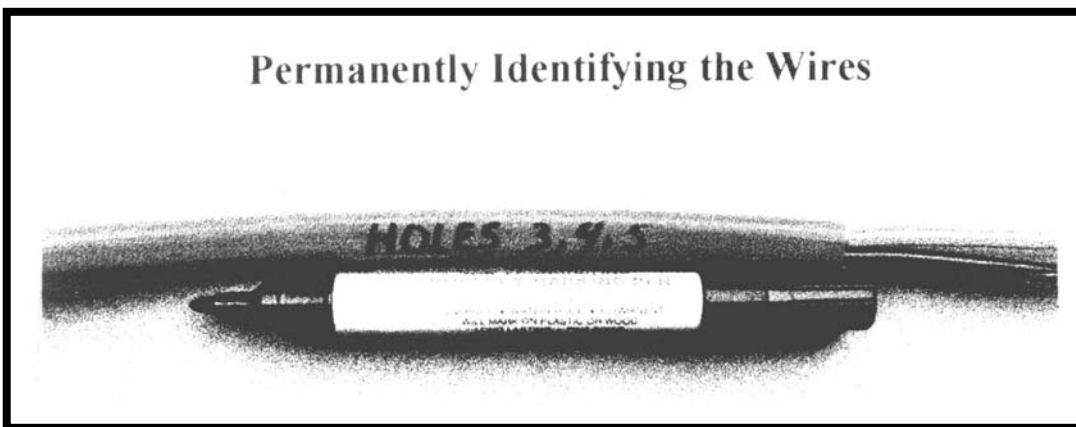

**FIGURE: 3.3**

## Stripping the Outer Jacket

**STRIPPING THE OUTER JACKET OF THE MAXI TWO-WIRE CABLE** - As noted earlier, extreme care is necessary during the wiring phase of the project. The following is a detailed description of the best method to strip the outer jacket of the two-wire cable that minimizes the chances of cutting through the inner insulation and into the copper conductors themselves.

Strip approximately 6" of the outer jacket of the cable for all the splices that are to be made.. It can be difficult to attempt to remove all 6" of the outer insulation in one piece, so remove it in two 3" sections.

The acceptable knife that allowed for this procedure is the small snap-off blade variety. **Refer to FIGURE: 3.4 below.** It is recommended that you grind off the point of the knife blade to minimize the chances of piercing the inner insulation. The King Safety stripper may also be used but care must be taken to cut away from the conductors when removing the remaining outer jacket so as not to damage the inner conductor insulation.

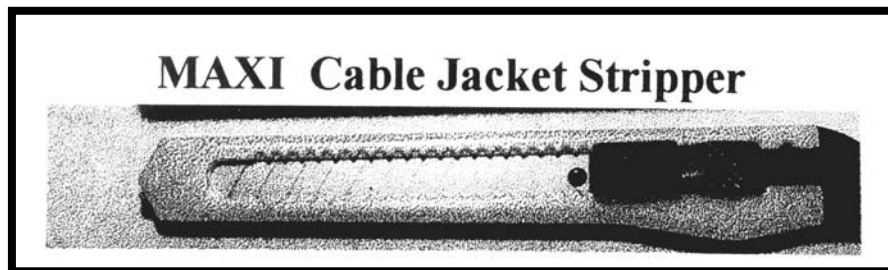

**FIGURE: 3.4**

The blade of the knife should be set and locked at its minimum extension to prevent a cut in the inner insulation. **This is the most crucial aspect of the entire wiring procedure.** DO NOT use hook knives, pocket knives, utility knives, or ROMEX strippers since you have no way to limit the depth of your cut and therefore all have the possibility of cutting through the inner insulation if you attempt to use them.

Hold the MAXI two-wire cable in one hand and while holding the blade against the outer jacket with the other hand, score the outside of the jacket. **Refer to FIGURE: 3.5 below.**

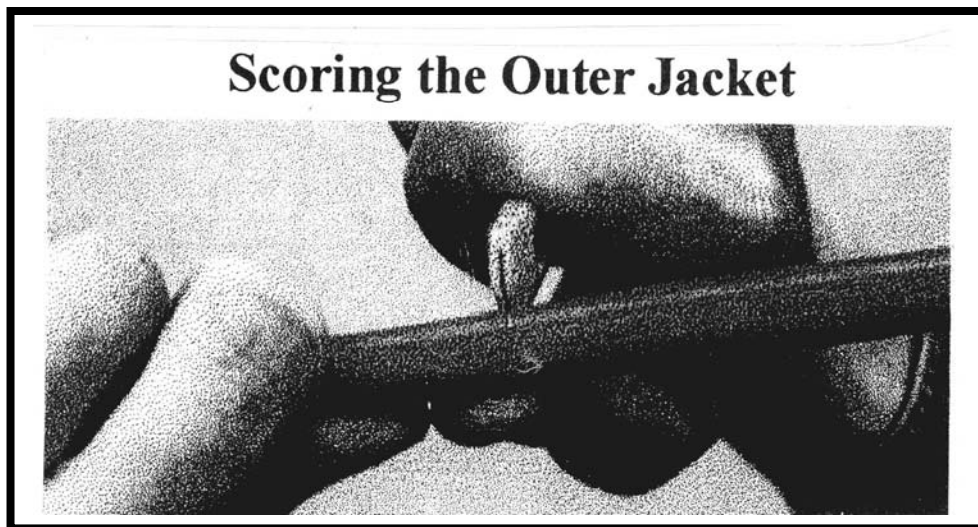

**FIGURE: 3.5**

Now **Gently** flex the cable to crack the outer jacket. **Refer to FIGURE: 3.6 below.** DO NOT bend it back and forth more than is absolutely necessary since it is possible to break the inner conductor within the inner insulation and not be aware that it happened. Once the outer jacket is cracked, simply pull the outer insulation jacket off, leaving the two inner PVC insulated conductors, one RED and the one BLACK, exposed.

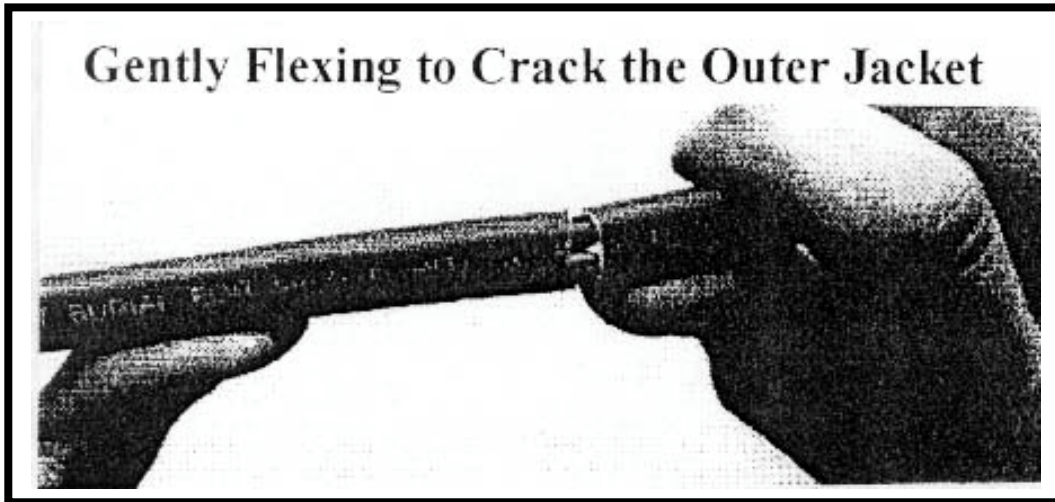

**FIGURE: 3.6**

After about 6" of the RED and BLACK insulated conductors are exposed, use a wire strippers of proper gauge to remove approximately 5/8" of the PVC inner insulation from these conductors. A wire stripper similar to that pictured in **FIGURE: 3.7 below** has been found to work best, since they can also strip the insulation from other conductors encountered during the installation.

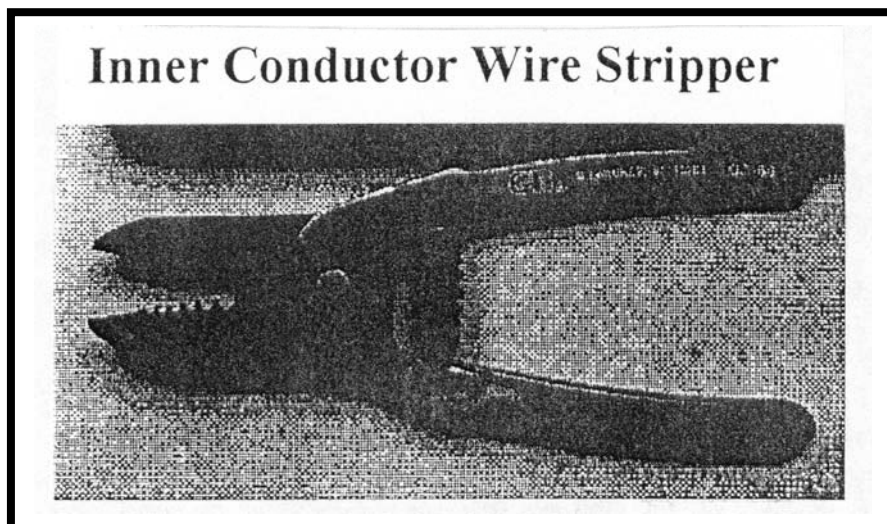

**FIGURE: 3.7**

## Making the Wire Splice

**MAKING WIRE SPLICE** – When making an inline wire splice use a linesman’s pliers to gently twist one of the red insulated conductors to the other red insulated conductor and one of the black insulated conductors to the other black insulated conductor. Place no more than three or four twists in the wire. Twisting the wires in excess can fracture the conductors. *Refer to FIGURE: 3.8 below.*

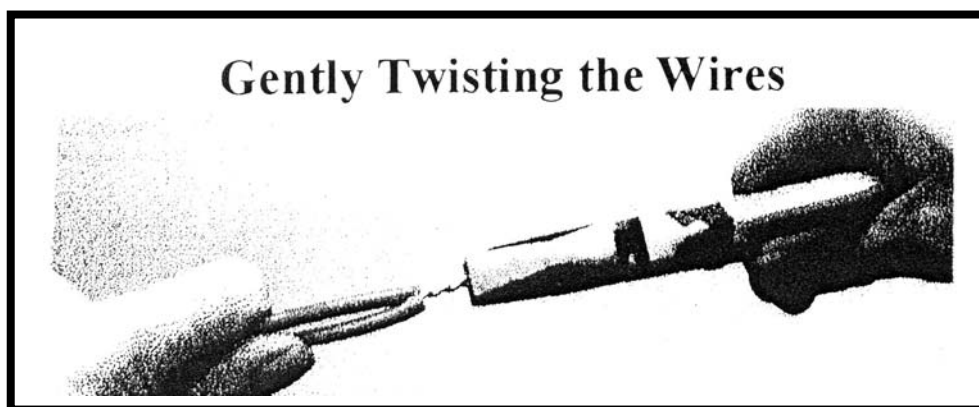

**FIGURE: 3.8**

Other splicing techniques will be covered later in this manual for guidelines in regard to decoder wiring. **The following points hold true in every splice that will be made, however, and are VERY important.**

- Do **NOT** lay the two wires together to be held by the wire nut and do **NOT** over tighten the twists as it is possible to stretch the wire and weaken it, which can then break when wire-nutted and the break may not be apparent to you.
- When the wires are twisted together, firmly hand tighten the appropriate size wire nut onto the twisted wire and push it into the DBY or DBR connector as far as possible and secure the cap.
- If making a three-way splice, mark the wires permanently with the hole numbers or areas of the golf course the wire comes from and where each is going.
- This and all other splices should be placed in a valve box with the mandatory one foot (1'-0") above grade minimum amount of slack.

# DECODER WIRING PROCEDURES:

## GENERAL INSTRUCTIONS:

The following instructions shall apply to ALL the different wiring configurations presented here in this section of the manual.

**WIRING OF DECODER INPUT & OUTPUT WIRES** – Each remote control valve will be wired to a decoder and the decoder in turn wired into the Two-Wire communication path. The two (2) *blue* wires of the decoder connect into the Two-Wire communication path, one to the **RED** insulated wire of the Two-Wire cable and the other to the **BLACK** insulated wire of the cable. It does not matter which of the *blue* wires, of the decoder, connect to the **red** and which to the **black** wire of the two-wire cable. The two output decoder wires are *white* and each connect to one of the two wires from the solenoid coil. Again it does not matter which of the wires from the decoder connect to which wires of the solenoid coil. The procedures for proper splicing of an inline splice apply. It may be necessary to strip a small additional amount of the insulation from the *blue* and *white* wires of the decoder as well as from the wires of the solenoid coil to provide enough bare copper conductor to work with in making the splice.

After you have made the “twist” connection of the **RED** to **RED** insulated wires and the **BLACK** to **BLACK** insulated wires of the two ends of the Two-Wire communication cable, you are ready to connect the *blue* wires from the decoder. Lay the bare copper conductor, from one of the *blue* decoder wires, into the twisted wire “groove” between the two copper conductors from the **RED** insulated wire splice and follow the twist using either your fingers or linesman’s pliers. Repeat for the other *blue* wire from the decoder, laying the conductor into the twisted wire “groove” between the two copper conductors from the **BLACK** insulated wire splice and follow the twist using either your fingers or linesman’s pliers. Place a wire nut on each of these splices and then insert each splice into a **3-M DBR** connector, making sure you insert it into the connector as far as possible, and then snap the cap securely in place. *Refer to FIGURE: 3.9 below.*



**FIGURE: 3.9**

**CONNECTING THE DECODER OUTPUT** –The decoder *white* output wires are to be connected to the wires on the solenoid coil of the Valve-in-Head sprinklers or the remote control valve. It may be necessary to strip a small amount of additional insulation off the solenoid wires, as well as, from the decoder *white* output wires to provide enough bare copper conductor to work with in making the splices. Take one of the *white* decoder output wires and hold it parallel to one of the solenoid coil wires and using your fingers or a linesman’s pliers, twist the two wires together. *Use a CLOCKWISE direction in making the twist so that in applying the wire nut it will not cause the wires to “un-twist”.* Repeat this procedure for the other decoder *white* output wire and the remaining solenoid coil wire. Place a wire nut on each of these splices and then insert each splice into a **3-M DBY** connector, making sure you insert it into the connector as far as possible, and then snap the cap securely in place. *Refer to FIGURE: 3.10 below.*

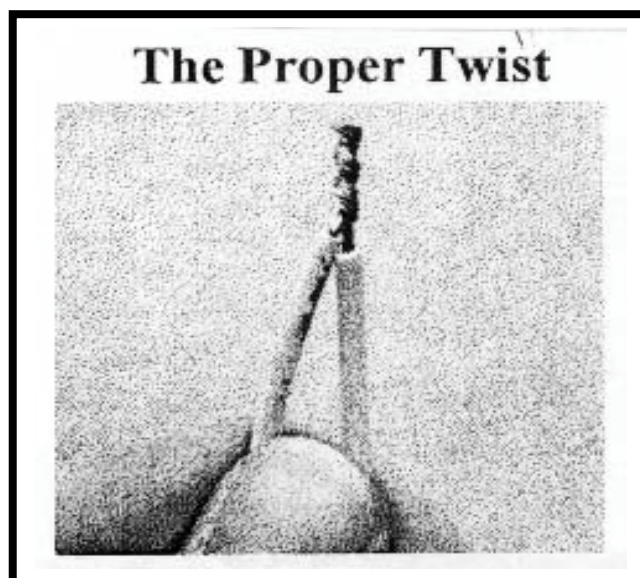

**FIGURE: 3.10**

**SPLICING TECHNIQUES – The following points hold true in every splice that you will be making and all are very important.**

- Do **NOT** lay the two wires together and depend on a twist being made by the wire nut
- Do **NOT** over tighten the twists as it is possible to stretch the wire and weaken it, which can then break when the wire nut is applied and the break may not be apparent to you.
- When the wires are twisted together, firmly hand tighten the appropriate size wire nut onto the twisted wire and push it into the DBY or DBR connector as far as possible and secure the cap.
- If making a three-way splice, mark the wires permanently with the hole numbers or areas of the golf course the wire comes from and where each is going.

**RECORDING OF DECODER ADDRESS CODE – At this point, record the four or five digit decoder address code, on either a “Start-Up Work Sheet” and/or on a drawing of the irrigation system layout for the course, making sure you identify the proper location in the field for this decoder. This data will need to be on the “Start-Up Work Sheet” along with all the other necessary information to do the initial data entry into the computer. The decoders can be installed in any random address code order and do not need to be installed sequentially. The important thing is to accurately record the address code at the proper decoder.**

**This section covers the different wiring configurations commonly encountered in a decoder system. Any given installation may incorporate several of these concepts.**



# DECODER and VALVE-IN-HEAD SPRINKLER INSTALLATION METHODS

**SINGLE ROW FAIRWAY SYSTEM** - This is perhaps one of the most common type systems. In this type system it is common to have one decoder for each fairway Valve-in-Head sprinkler. Therefore, the Rain Bird Model FD-102 type decoder, which is a single address decoder, is most generally used. For the Greens, Tees, Approaches, Perimeters and Roughs many times another type decoder will be utilized depending upon the design.

## CONFIGURATION #2:

### FD-102 DECODER CONTROLLING SPRINKLER

**A TYPICAL INSTALLATION** – A typical installation detail is shown in **FIGURE: 3.12** below, for a single FD-102 decoder controlling a single Valve-in-Head sprinkler. An FD-102 decoder is required for each Valve-in-Head sprinkler, that is to operate individually and that is installed in a single row, down the center of each fairway or other locations of the course, where individual operation of the Valve-in-Head sprinkler is desired.

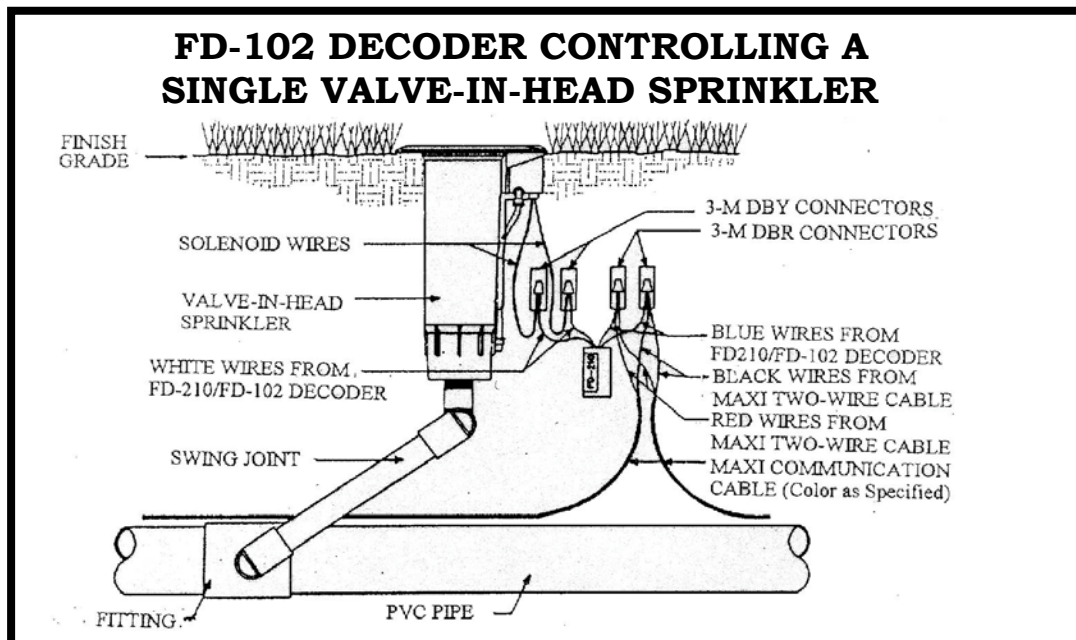

**FIGURE: 3.12**

**FIRST** – Strip the outer jacket from each end of the two-wire communication cable, where you are going to install the decoder for the Valve-in-Head sprinkler. *Refer to previous area “Stripping the Outer Jacket”.* Then from each end of the conductors in the communication cable, strip approximately 5/8” of the PVC inner insulation from the conductors. *Refer to FIGURE: 3.7 shown previously,* for proper type of wire stripper to use.

**MAKING THE WIRE SPLICE** – When making an inline wire splice use a linesman’s pliers to gently twist one of the red insulated conductors to the other red insulated conductor and one of the black insulate conductors to the other black insulated conductor. Place no more than three or four twists in the wire. Twisting the wires in excess can fracture the conductors. *Refer to FIGURE: 3.8 shown previously.*

**LOCATION OF DECODER** - The wiring procedure is the same as it is for a remote control or “block” valve with the exception that the decoder and splices will be directly buried beside the Valve-in-Head sprinkler instead of in a valve box. It is important that the **LOCATION OF THE DECODER AND SPLICES REMAIN CONSISTENT** through out the entire course. It is recommended that the assembly be buried directly below the manual valve actuator 6” below grade. **DO NOT TAPE** the decoder and splice assembly to the Valve-in-Head sprinkler, as this would prevent removal of the sprinkler head from the riser without first digging down and un-taping the assembly. Otherwise, the solenoid coil can just be slipped off the core tube and the sprinkler then can be un-screwed from the riser. As with all splices, leave enough slack so as to be able to lift the assembly at least 1’-0” above the finish grade. Orient the DBR’s and DBY’s above the decoder and all the wires. In this way they will serve to protect the wires from being nicked, by alerting you that you’re close to the wires if any digging is required in this area in the future.

**NOTE !**                      **Refer to “Decoder Wiring Procedures” - General Instructions – shown on Page 39.**

## CONFIGURATION #3:

### ONE DECODER FD-102 CONTROLLING TWO VALVE-IN-HEAD SPRINKLERS

TWO SPRINKLERS OPERATING FROM ONE DECODER – Another method of control on a single row fairway system is to operate and control two (2) sprinklers together from one single decoder. This is illustrated below. *Refer to FIGURE: 3.13below.*

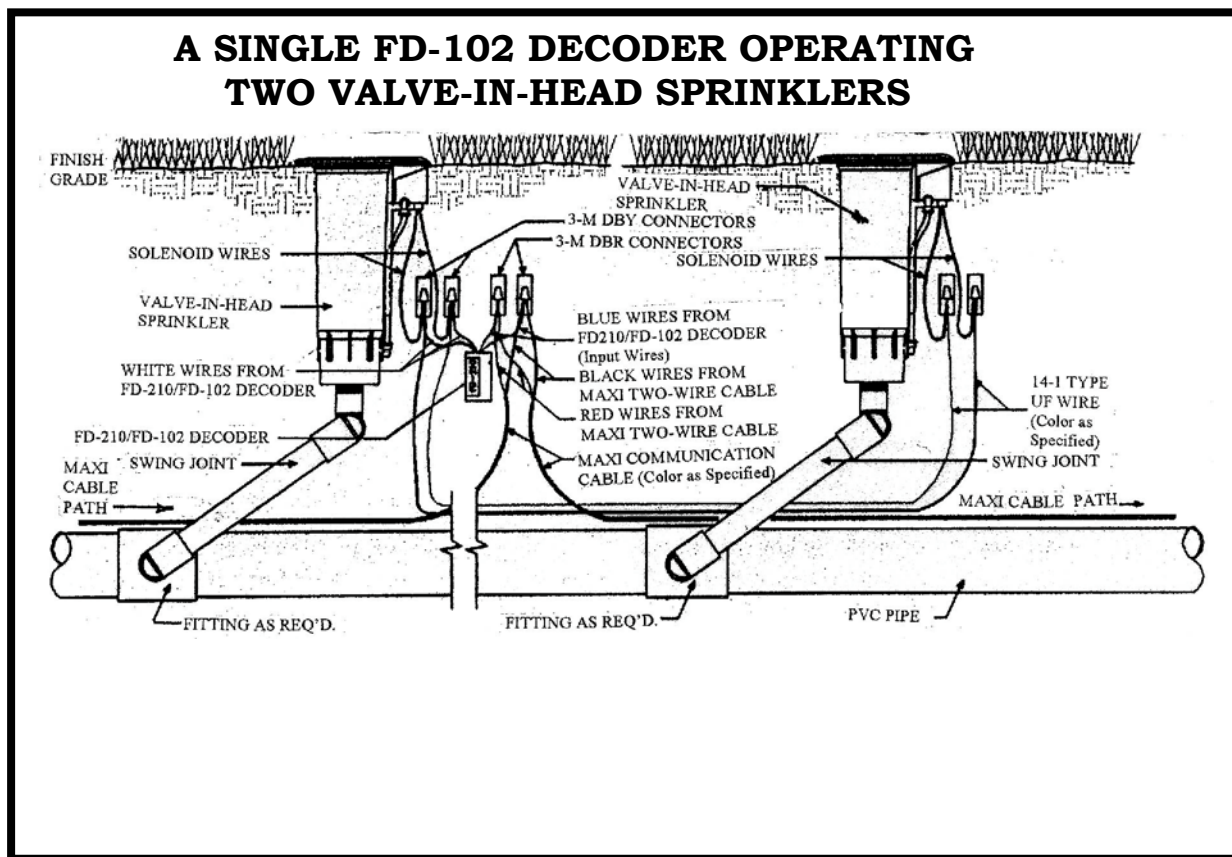

**FIGURE: 3.13**

**LOCATION OF DECODER** – Where two (2) Valve-in-Head sprinklers are to be operated from a single FD-102 decoder, locate the decoder at the first Valve-in-Head in line. The wiring procedure is similar to that for a remote control or “block” valve with the exception that the decoder and splices will be directly buried beside the first Valve-in-Head sprinkler, instead of in a valve box. In addition there is a second Valve-in-Head sprinkler also being controlled by this same decoder. It is important that the **LOCATION OF THE DECODER AND SPLICES REMAIN CONSISTENT** through out the entire course. It is recommended that the assembly be buried directly below the manual valve actuator 6” below grade. **DO NOT TAPE** the decoder and splice assembly to the Valve-in-Head sprinkler, as this would prevent removal of the sprinkler head from the riser without first digging down and un-taping the assembly. Otherwise, the solenoid coil can just be slipped off the core tube and the sprinkler then can be un-screwed from the riser. As with all splices, leave enough slack so as to be able to lift the assembly at least 1’-0” above the finish grade. Orient the DBR’s and DBY’s above the decoder and all the wires. In this way they will serve to protect the wires from being nicked, by alerting you that you’re close to the wires if any digging is required in this area in the future.

**FIRST** – Strip the outer jacket from each end of the two-wire communication cable, where you are going to install the decoder for the Valve-in-Head sprinkler. *Refer to previous area “Stripping the Outer Jacket”.* Then from each end of the conductors in the communication cable, strip approximately 5/8” of the PVC inner insulation from the conductors. *Refer to FIGURE: 3.7 shown previously,* for proper type of wire stripper to use.

**MAKING THE WIRE SPLICE** – When making an inline wire splice use a linesman’s pliers to gently twist one of the red insulated conductors to the other red insulated conductor and one of the black insulate conductors to the other black insulated conductor. Place no more than three or four twists in the wire. Twisting the wires in excess can fracture the conductors. *Refer to FIGURE: 3.8 shown previously.*

**WIRING OF DECODER INPUT & OUTPUT WIRES** – The first in-line Valve-in-Head Sprinkler will be wired to a FD-210/FD-102 decoder and the decoder in turn wired into the Two-Wire communication path. The two (2) **blue** input wires of the decoder connect into the Two-Wire communication path, one to the **RED** insulated wires of the Two-Wire cable and the other to the **BLACK** insulated wires of the cable. It does not matter which of the **blue** wires, from the decoder, connect to the **red** and which to the **black** wires of the two-wire cable. The two output decoder wires are **white** and each connects to one of the two wires coming **from** the solenoid coil. In addition the solenoid at the second Valve-in-Head sprinkler (that is to be controlled by this decoder) is to be connect to the decoder’s **white** output wires also. Splice a pair of 14-1 wires into the connections between the **white** decoder output wires and the solenoid wires for the first Valve-in-Head sprinkler. Use 3-M DBR connectors for these splices. This

additional wire will run the distance between the first Valve-in-Head sprinkler and the second Valve-in-Head sprinkler. **Refer to FIGURE: 3.13 shown previously.** Connect each of these wires to the solenoid wires of the second Valve-in-Head sprinkler using 3-M DBY connectors.. Again it does not matter which of the wires from the decoder connect to which wires of the solenoid coil. The procedures for proper splicing of an inline splice apply to all of these splices.. It may be necessary to strip a small additional amount of the insulation from the **blue** and **white** wires of the decoder as well as from the wires of the solenoid coil to provide enough bare copper conductor to work with in making the splice. If this is a “retrofit” of an existing system, this wire can be installed with a vibratory plow or if it is a new piping network, the additional wire can be laid in the trench between the first and second Valve-in-Head sprinklers and located as specified earlier in this manual

## CONFIGURATION #4:

### ONE DECODER FD-102 CONTROLLING TWO VALVE-IN-HEAD SPRINKLERS IN A BLOCK CONFIGURATION

TWO VALVE-IN-HEAD SPRINKLERS IN “BLOCK” CONFIGURATION BEING OPERATED FROM ONE DECODER – Another method of control of valve-in-head sprinklers in a “block” configuration is the two operating together from one single decoder. This is illustrated below. Refer to FIGURE: 3.14 below.

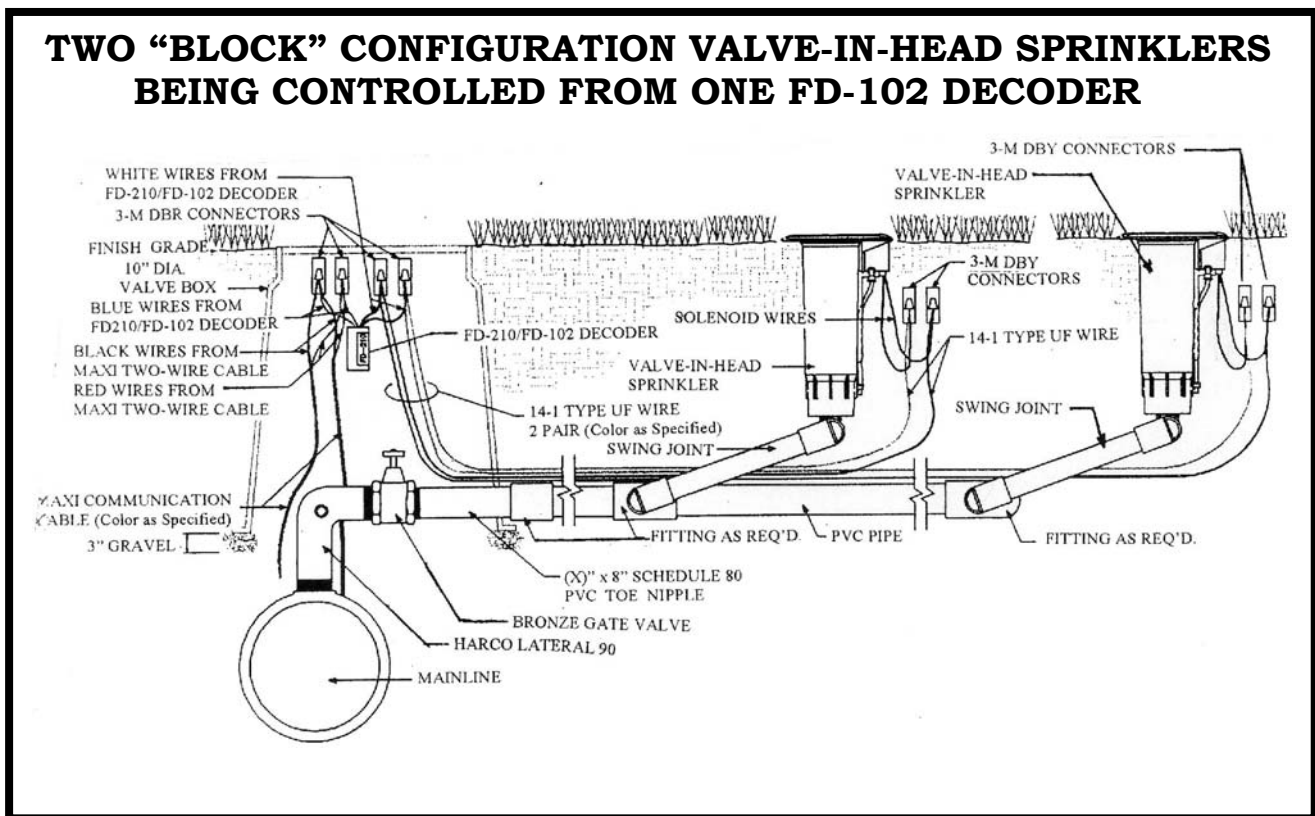

**FIGURE: 3.14**

**LOCATION OF DECODER** - Where two (2) Valve-in-Head sprinklers, in a “block configuration,” are to be operated from a single FD-102 decoder, the decoder shall be located at the mainline where the lateral line takes-off from it. The decoder and wire splices shall be installed at this location in a 10” diameter valve box. Leave enough “slack” in the wires so that the splices can be extended above the finish grade a minimum of 1’-0” for future ease of maintenance.

At each of the Valve-in-Head sprinklers in the block the wire splices shall be directly buried about 6” below finish grade and directly beneath the solenoid/actuator of the sprinkler. It is important that the **LOCATION OF THE SPLICES REMAIN CONSISTENT** through out the entire course. **DO NOT TAPE** the splice assembly to the Valve-in-Head sprinkler, as this would prevent removal of the sprinkler head from the riser without first digging down and un-taping the assembly. Otherwise, the solenoid coil can just be slipped off the core tube and the sprinkler then can be un-screwed from the riser. As with all splices, leave enough slack so as to be able to lift the assembly at least 1’-0” above the finish grade.

**FIRST** – Strip the outer jacket from each end of the two-wire communication cable, where you are going to install the decoder, near the lateral take-off and which will control the “block” configuration Valve-in-Head sprinklers. *Refer to previous area “Stripping the Outer Jacket”.* Then from each end of the conductors in the communication cable, strip approximately 5/8” of the PVC inner insulation from the conductors. *Refer to FIGURE: 3.7 shown previously,* for proper type of wire stripper to use.

**MAKING THE WIRE SPLICE** – When making an inline wire splice use a linesman’s pliers to gently twist one of the red insulated conductors to the other red insulated conductor and one of the black insulate conductors to the other black insulated conductor. Place no more than three or four twists in the wire. Twisting the wires in excess can fracture the conductors. *Refer to FIGURE: 3.8 shown previously.*

**WIRING OF DECODER INPUT & OUTPUT WIRES** – The FD-102 decoder shall be wired into the Two-Wire communication path at this lateral take-off location. The two (2) **blue** input wires of the decoder connect into the Two-Wire communication path, one to the **RED** insulated wires of the Two-Wire cable and the other to the **BLACK** insulated wires of the cable. It does not matter which of the **blue** wires, from the decoder, connect to the **red** and which to the **black** wires of the two-wire cable. The two output decoder wires are **white** and each connects to one of the two wires coming from each solenoid coil of the two (2) Valve-in-Head sprinklers being controlled by this decoder. Splice two (2) pair of 14-1 wires to the two **white** decoder output wires. Use 3-M DBR connectors for these splices. One pair, of these two (2) pair of wires, will run the distance between the decoder and the first Valve-in-Head sprinkler of the block. The second pair of wires will run the distance from the decoder to the second Valve-in-Head sprinkler of the block. The maximum wire run between the decoder and the Valve-in-Head sprinkler **must not exceed 328 feet.** *Refer to FIGURE: 3.14 shown previously.* Connect each of the wires, in each pair, to their respective solenoid coils of the Valve-in-Head sprinklers using a 3-M DBY connectors at each splice. Again it does not matter which of the wires from the decoder connect to which wires of the solenoid coil as long as you keep the pairs straight. (It is suggested that different color of wires be used for each pair for easy identification.) The procedures for proper splicing of an inline splice apply to all of these splices.. It may be necessary to strip a small additional amount of the insulation from the **blue** and **white** wires of the decoder as well as from the wires of the solenoid coils to provide enough bare copper

conductor to work with in making the splice. If this is a “retrofit” of an existing system, this wire can be installed with a vibratory plow or if it is a new piping network, the additional wire can be laid in the trench between the first and second Valve-in-Head sprinklers and located as specified earlier in this manual

**CHECKING THE WIRING** – After you have made all the decoder output wire splices at the solenoid coils at each of the two Valve-in-Head sprinklers but before connecting to the decoder, check the resistance at the decoder end of these wires, using an OHM meter to measure the resistance to make sure the wires are connected to the solenoid properly. You should have approximately **24 to 29 Ohms** of resistance. After the test then make the connections to the decoder. For a proper installation you need to know which pair is connected to which Valve-in-Head sprinkler on the lateral. Mark or Tag each pair accordingly for future reference.

**CONNECTING THE DECODER OUTPUT** –One of the 14-1 pair of UF wires coming from the decoder *white* output wires are to be connected to the wires on the solenoid coil of the first Valve-in-Head sprinkler of the block.. It may be necessary to strip a small amount of additional insulation off the solenoid wires to provide enough bare copper conductor to work with in making the splices. Take one of the wires in the 14-1 pair from the decoder output wires and hold it parallel to one of the solenoid coil wires and using your fingers or a linesman’s pliers, twist the two wires together. *Use a CLOCKWISE direction in making the twist so that in applying the wire nut it will not cause the wires to “un-twist”*. Repeat this procedure for the other wire in the pair from the decoder output wires and the remaining solenoid coil wire. Place a wire nut on each of these splices and then insert each splice into a **3-M DBY** connector, making sure you insert it into the connector as far as possible, and then snap the cap securely in place. *Refer to FIGURE: 3.10 shown previously and also FIGURE 3.12 shown previously.*

The second 14-1 pair of UF wires coming from the decoder *white* output wires are to be connected to the wires on the solenoid coil of the second Valve-in-Head sprinkler of the block.. It may be necessary to strip a small amount of additional insulation off the solenoid wires to provide enough bare copper conductor to work with in making the splices. Take one of the wires in the 14-1 pair from the decoder output wires and hold it parallel to one of the solenoid coil wires and using your fingers or a linesman’s pliers, twist the two wires together. *Use a CLOCKWISE direction in making the twist so that in applying the wire nut it will not cause the wires to “un-twist”*. Repeat this procedure for the other wire in the pair from the decoder output wires and the remaining solenoid coil wire. Place a wire nut on each of these splices and then insert each splice into a **3-M DBY** connector, making sure you insert it into the connector as far as possible, and then snap the cap securely in place. *Refer to FIGURE: 3.10 shown previously and also FIGURE 3.12 shown previously.*

## CONFIGURATION #5:

### FD-202 DECODER CONTROLLING TWO VALVE-IN-HEAD SPRINKLERS INDEPENDENTLY IN A BLOCK CONFIGURATION

**T**WO VALVE-IN-HEAD SPRINKLERS IN “BLOCK” CONFIGURATION BEING INDIVIDUALLY OPERATED FROM ONE DECODER – Another method of control of valve-in-head sprinklers in a “block” configuration is the two operating independently from one single decoder. This is illustrated below. Refer to FIGURE: 3.15 below.

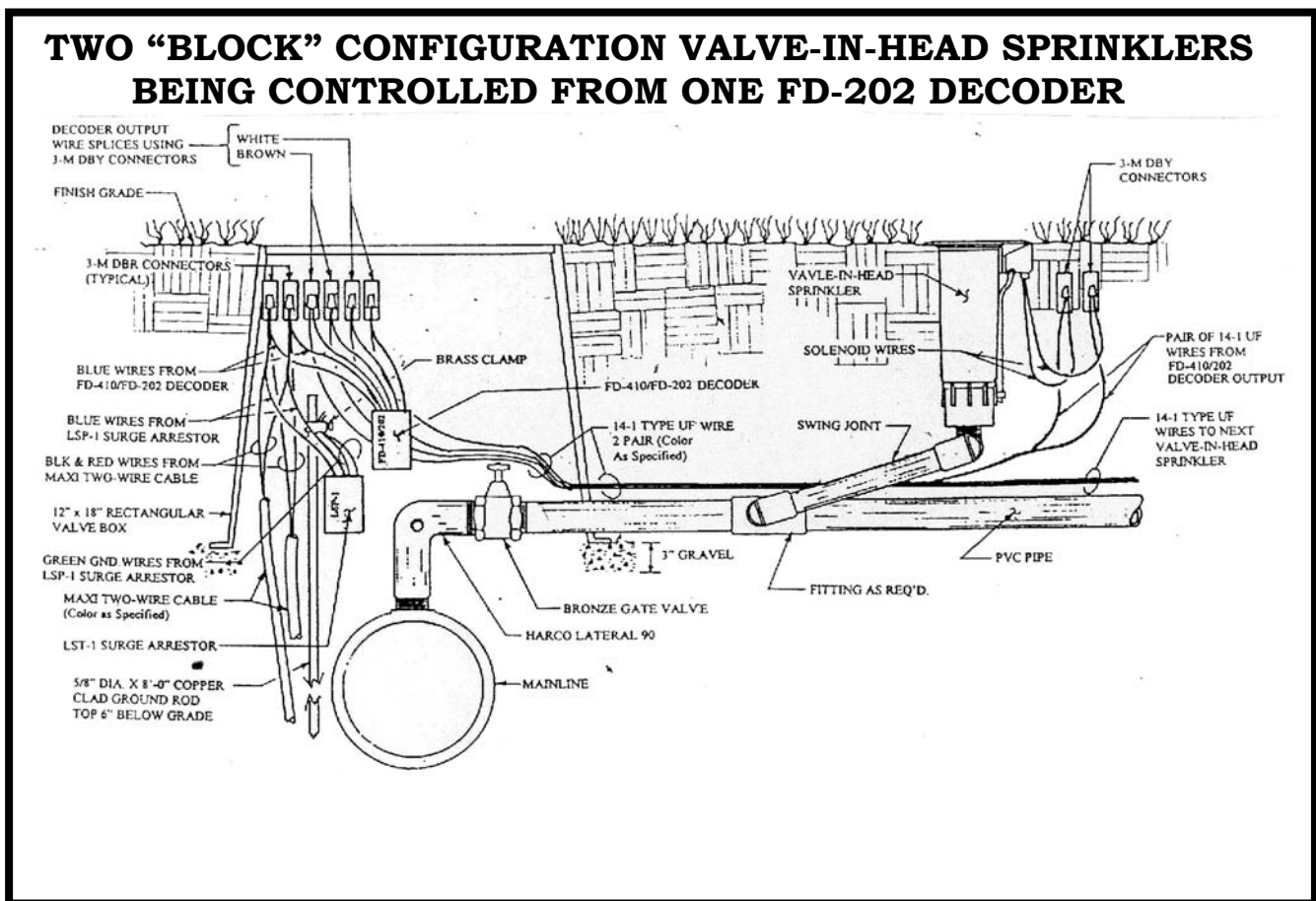

**FIGURE: 3.15**

**LOCATION OF DECODER** - Where two (2) Valve-in-Head sprinklers, in a “block configuration,” are to be operated from a single FD-202 decoder, the decoder shall be located at the mainline where the lateral line takes-off from it. The decoder and wire splices shall be installed at this location in a 12” x 18” or larger, rectangular valve box. Leave enough “slack” in the wires so that the splices can be extended above the finish grade a minimum of 1’-0” for future ease of maintenance.

At each of the Valve-in-Head sprinklers, in the block, the wire splices shall be directly buried about 6” below finish grade and directly beneath the solenoid/actuator of the sprinkler. It is important that the **LOCATION OF THE SPLICES REMAIN CONSISTENT** through out the entire course. **DO NOT TAPE** the splice assembly to the Valve-in-Head sprinkler, as this would prevent removal of the sprinkler head from the riser without first digging down and un-taping the assembly. Otherwise, the solenoid coil can just be slipped off the core tube and the sprinkler then can be un-screwed from the riser. As with all splices, leave enough slack so as to be able to lift the assembly at least 1’-0” above the finish grade.

**FIRST** – Strip the outer jacket from each end of the two-wire communication cable, where you are going to install the decoder, near the lateral take-off and which will control the “block” configuration Valve-in-Head sprinklers. *Refer to previous area “Stripping the Outer Jacket”.* Then from each end of the conductors in the communication cable, strip approximately 5/8” of the PVC inner insulation from the conductors. *Refer to FIGURE: 3.7 shown previously,* for proper type of wire stripper to use.

**MAKING THE WIRE SPLICE** – When making an inline wire splice use a linesman’s pliers to gently twist one of the red insulated conductors to the other red insulated conductor and one of the black insulate conductors to the other black insulated conductor. Place no more than three or four twists in the wire. Twisting the wires in excess can fracture the conductors. *Refer to FIGURE: 3.8 shown previously.*

**WIRING OF DECODER INPUT & OUTPUT WIRES** – The **FD-401** decoder shall be wired into the Two-“Wire communication path at this lateral take-off location.

**DECODER INPUT WIRING:** The two (2) **blue** input wires of the decoder connect into the Two-Wire communication path, one to the **RED** insulated wires of the Two-Wire cable and the other to the **BLACK** insulated wires of the cable. It does not matter which of the **blue** wires, from the decoder, connect to the **red** and which to the **black** wires of the two-wire cable. **In addition;** the two (2) **green** ground wires from the decoder should be attached to a ground rod at this location. Use 3-M DBR connectors for these splices. *Refer to FIGURE: 3.15 shown previously.*

**DECODER OUTPUT WIRING:** There are two pair of output decoder wires from this decoder. One pair are *white* and the other pair are *brown*. One pair are to be connected to the two solenoid wires coming from the solenoid coil of one of the two (2) Valve-in-Head sprinklers being controlled by this decoder. The second pair are to be connected to the two solenoid wires coming from the solenoid coil of the other Valve-in-Head sprinkler. The maximum wire run between the decoder and the Valve-in-Head sprinkler ***must not exceed 328 feet.*** In order to make these connections it is necessary to splice a pair of 14-1 wires into each of the decoder output pair of wires. In order to keep the wires identified for each of the sprinklers, use a different color of wire for each of the pairs. Take one of the wires in the one 14-1 pair and one of the *brown* decoder output wires and hold them parallel to each other. Using your fingers or a linesman's pliers, twist the two wires together. ***Use a CLOCKWISE direction in making the twist so that in applying the wire nut it will not cause the wires to "un-twist".*** Use a 3-M DBY connector for this splice. The other wire of this pair and the other *brown* decoder wires shall be spliced together in the same manner. Repeat this same process for the wires in the second 14-1 pair of wires and the two *white* decoder output wires. One pair of these two (2) pair of wires, will run the distance between the decoder and the first Valve-in-Head sprinkler of the block. The second pair of wires will run the distance from the decoder to the second Valve-in-Head sprinkler of the block. ***Refer to FIGURE: 3.15 shown previously.***

**SPRINKLER SOLENOID WIRING:** At the first Valve-in-Head sprinkler, connect each of the wires, in the pair controlling this sprinkler, to the respective solenoid coil wires of the Valve-in-Head sprinklers. Again it does not matter which of the wires from the decoder connect to which wires of the solenoid coil as long as you keep the pairs straight. (It is suggested that different color of wires be used for each pair for easy identification.) Take one of the wires in the 14-1 pair and one of the wires from the solenoid coil and hold them parallel to each other. Using your fingers or a linesman's pliers, twist the two wires together. ***Use a CLOCKWISE direction in making the twist so that in applying the wire nut it will not cause the wires to "un-twist".*** Place a wire nut on the splice and then insert the splice into a 3-M DBY connector, making sure you insert it into the connector as far as possible, and then snap the cap securely in place. ***Refer to FIGURE: 3.10 shown previously and also FIGURE 3.15 shown previously.*** Repeat this procedure for the second wire of this pair and the remaining solenoid coil wire. At the second Valve-in-Head sprinkler, connect each of the wires, in the pair controlling this sprinkler, to the respective solenoid coil wires of the Valve-in Head sprinkler. Follow the same procedure as outlined immediately above. The procedures for proper splicing of an inline splice apply to all of these splices.. It may be necessary to strip a small additional amount of the insulation from the wires of the solenoid coils to provide enough bare copper conductor to work with in making the splice. If this is a "retrofit" of an existing system, this wire can be installed with a vibratory plow or if it is a new piping network, the additional wire can be laid in the trench between the decoder location and the first and second Valve-in-Head sprinklers. Locate and install the wire in the trench, as specified earlier in this manual

**CHECKING THE WIRING** – After you have made all the decoder output wire splices, at the solenoid coils at each of the Valve-in-Head sprinklers but before connecting to the decoder, check the resistance, at the decoder end of these wires, using an OHM meter to measure the

resistance to make sure the wires are connected to the solenoid properly. You should have approximately **24 to 29 Ohms** of resistance. For a proper installation you need to know which pair is connected to which Valve-in-Head sprinkler on the lateral. Mark or Tag each pair accordingly for future reference.

**RECORDING OF DECODER ADDRESS CODE** – At this point, **record the four or five digit decoder address codes**, for this decoder. (Remember that there are **TWO (2) ADDRESSES** for this decoder). You must not only identify the correct address code but also indicate which of the Valve-in-Head sprinklers the address is controlling. This data needs to be recorded on either a “Start-Up Work Sheet” and/or on a drawing of the irrigation system layout for the course, making sure you identify the proper location in the field for this decoder and of the sprinklers. This data will need to be on the “Start-Up Work Sheet” along with all the other necessary information to do the initial data entry into the computer. The decoders can be installed in any random address code order and do not need to be installed sequentially. **The important thing is to accurately record the address code for the proper decoder and to properly identify the corresponding sprinkler this address will control.**

## CONFIGURATION #6:

### FD-401 DECODER CONTROLLING FOUR VALVE-IN-HEAD SPRINKLERS INDEPENDENTLY IN A BLOCK CONFIGURATION

**F**OUR VALVE-IN-HEAD SPRINKLERS IN “BLOCK” CONFIGURATION BEING INDIVIDUALLY OPERATED FROM ONE DECODER – Using an FD-401 decoder four valve-in-head sprinklers, in a “block” configuration, can each be operated independently from one single decoder. This is illustrated below. *Refer to FIGURE: 3.16 below.*

#### FOUR “BLOCK” CONFIGURATION VALVE-IN-HEAD SPRINKLERS BEING INDEPENDENTLY CONTROLLED FROM ONE FD-401 DECODER

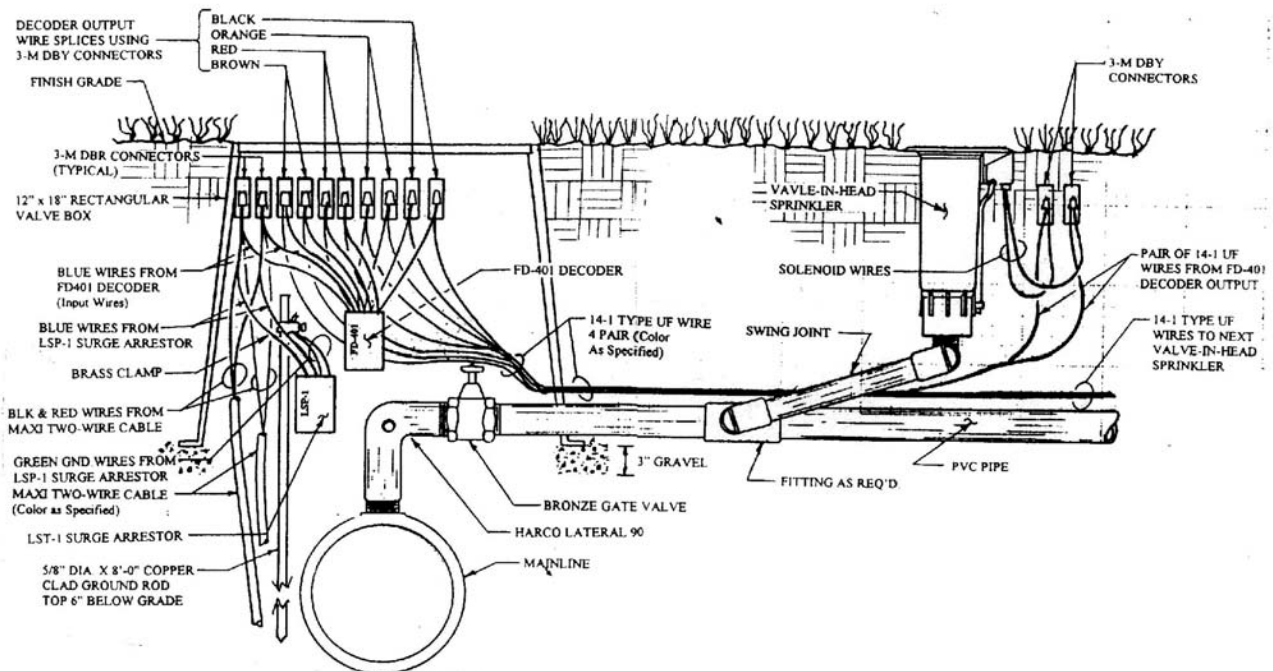

**FIGURE: 3.16**

**LOCATION OF DECODER** - Where four (4) Valve-in-Head sprinklers, in a “block configuration,” are to be operated from a single FD-401 decoder, the decoder shall be located at the mainline where the lateral line takes-off from it. The decoder and wire splices shall be installed at this location in a 12” x 18” or larger, rectangular valve box. Leave enough “slack” in the wires so that the splices can be extended above the finish grade a minimum of 1’-0” for future ease of maintenance.

At each of the Valve-in-Head sprinklers, in the block, the wire splices shall be directly buried about 6” below finish grade and directly beneath the solenoid/actuator of the sprinkler. It is important that the **LOCATION OF THE SPLICES REMAIN CONSISTENT** through out the entire course. **DO NOT TAPE** the splice assembly to the Valve-in-Head sprinkler, as this would prevent removal of the sprinkler head from the riser without first digging down and un-taping the assembly. Otherwise, the solenoid coil can just be slipped off the core tube and the sprinkler then can be un-screwed from the riser. As with all splices, leave enough slack so as to be able to lift the assembly at least 1’-0” above the finish grade.

**FIRST** – Strip the outer jacket from each end of the two-wire communication cable, where you are going to install the decoder, near the lateral take-off and which will control the “block” configuration Valve-in-Head sprinklers. *Refer to previous area “Stripping the Outer Jacket”.* Then from each end of the conductors in the communication cable, strip approximately 5/8” of the PVC inner insulation from the conductors. *Refer to FIGURE: 3.7 shown previously,* for proper type of wire stripper to use.

**MAKING THE WIRE SPLICE** – When making an inline wire splice use a linesman’s pliers to gently twist one of the red insulated conductors to the other red insulated conductor and one of the black insulate conductors to the other black insulated conductor. Place no more than three or four twists in the wire. Twisting the wires in excess can fracture the conductors. *Refer to FIGURE: 3.8 shown previously.*

**WIRING OF DECODER INPUT & OUTPUT WIRES** – The **FD-401** decoder shall be wired into the Two-“Wire communication path at this lateral take-off location.

**DECODER INPUT WIRING:** The two (2) **blue** input wires of the decoder connect into the Two-Wire communication path, one to the **RED** insulated wires of the Two-Wire cable and the other to the **BLACK** insulated wires of the cable. It does not matter which of the **blue** wires, from the decoder, connect to the **red** and which to the **black** wires of the two-wire cable. **In addition;** the two (2) **green** ground wires from the decoder should be attached to a ground rod at this location. Use 3-M DBR connectors for these splices. *Refer to FIGURE: 3.16 shown previously.*

**DECODER OUTPUT WIRING:** There are four (4) pair of output decoder wires from this decoder, a *brown*, *red*, *orange* and a *black* pair.. One pair are to be connected to the two solenoid wires coming from the solenoid coil of one of the four (4) Valve-in-Head sprinklers being controlled by this decoder. The second pair are to be connected to the two solenoid wires coming from the solenoid coil of the second Valve-in-Head sprinkler. The third pair are to be connected to the two solenoid wires coming from the solenoid coil of the third Valve-in-Head sprinkler. The fourth pair are to be connected to the two solenoid wires coming from the solenoid coil of the fourth Valve-in-Head sprinkler. The maximum wire run between the decoder and any of the Valve-in-Head sprinklers ***must not exceed 328 feet.*** In order to make these connections it is necessary to splice a pair of 14-1 wires into each of the decoder output pair of wires. In order to keep the wires identified for each of the sprinklers, use a different color of wire for each of the pairs. Take one of the wires in the one 14-1 pair and one of the *brown* decoder output wires and hold them parallel to each other. Using your fingers or a linesman's pliers, twist the two wires together. ***Use a CLOCKWISE direction in making the twist so that in applying the wire nut it will not cause the wires to "un-twist".*** Use a 3-M DBY connector for this splice. The other wire of this pair and the other *brown* decoder wire shall be spliced together in the same manner. Repeat this same process for the wires in the second, third and fourth 14-1 pair of wires and to the two *red*, *orange* and *black* decoder output wire pairs. One pair of these four (4) pair of wires, will run the distance between the decoder and the first Valve-in-Head sprinkler of the block. The second pair of wires will run the distance from the decoder to the second Valve-in-Head sprinkler of the block. The third pair of wires will run the distance from the decoder to the third Valve-in-Head sprinkler of the block. The fourth pair of wires will run the distance form the decoder to the fourth Valve-in-Head sprinkler of the block. ***Refer to FIGURE: 3.16 shown previously.***

**SPRINKLER SOLENOID WIRING:** At the first Valve-in-Head sprinkler, connect each of the wires, in the pair controlling this sprinkler, to the respective solenoid coil wires of the Valve-in-Head sprinklers. Again it does not matter which of the wires from the decoder connect to which wires of the solenoid coil as long as you keep the pairs straight. (It is suggested that different color of wires be used for each pair for easy identification.) Take one of the wires in the 14-1 pair and one of the wires from the solenoid coil and hold them parallel to each other. Using your fingers or a linesman's pliers, twist the two wires together. ***Use a CLOCKWISE direction in making the twist so that in applying the wire nut it will not cause the wires to "un-twist".*** . Place a wire nut on the splice and then insert the splice into a 3-M DBY connector, making sure you insert it into the connector as far as possible, and then snap the cap securely in place. ***Refer to FIGURE: 3.10 shown previously and also FIGURE 3.16 shown previously.*** Repeat this procedure for the second wire of this pair and the remaining solenoid coil wire.

At the second Valve-in-Head sprinkler, connect each of the wires, in the pair controlling this sprinkler, to the respective solenoid coil wires of the Valve-in Head sprinkler. Follow the same procedure as outlined immediately above. Do the same at the third and fourth Valve-in-Head sprinklers. The procedures for proper splicing of an inline splice apply to all of these splices.. It may be necessary to strip a small additional amount of the insulation from the wires of the solenoid coils to provide enough bare copper conductor to work with in making the splice. If this is a "retrofit" of an existing system, this wire can be installed with a vibratory plow or if it is

a new piping network, the additional wire can be laid in the trench between the decoder location and the first, second, third and fourth Valve-in-Head sprinklers. Locate and install the wire in the trench, as specified earlier in this manual

**CHECKING THE WIRING** – After you have made all the decoder output wire splices, at the solenoid coils at each of the Valve-in-Head sprinklers but before connecting to the decoder, check the resistance, at the decoder end of these wires, using an OHM meter to measure the resistance to make sure the wires are connected to the solenoid properly. You should have approximately **24 to 29 Ohms** of resistance. For a proper installation you need to know which pair is connected to which Valve-in-Head sprinkler on the lateral. Mark or Tag each pair accordingly for future reference.

**RECORDING OF DECODER ADDRESS CODE** – At this point, **record the four or five digit decoder address codes**, for this decoder. (Remember that there are **FOUR (4) ADDRESSES** for this decoder). You must not only identify the correct address code but also indicate which of the Valve-in-Head sprinklers the address is controlling. This data needs to be recorded on either a “Start-Up Work Sheet” and/or on a drawing of the irrigation system layout for the course, making sure you identify the proper location in the field for this decoder and of the sprinklers. This data will need to be on the “Start-Up Work Sheet” along with all the other necessary information to do the initial data entry into the computer. The decoders can be installed in any random address code order and do not need to be installed sequentially. **The important thing is to accurately record the address code for the proper decoder and to properly identify the corresponding sprinkler this address will control.**



**LOCATION OF DECODER** - Where six (6) Valve-in-Head sprinklers, in a “block configuration,” are to be operated from a single FD-601 decoder, the decoder shall be located at the mainline where the lateral line takes-off from it. The decoder and wire splices shall be installed at this location in a 12” x 18” or larger, rectangular valve box. Leave enough “slack” in the wires so that the splices can be extended above the finish grade a minimum of 1’-0” for future ease of maintenance.

At each of the Valve-in-Head sprinklers, in the block, the wire splices shall be directly buried about 6” below finish grade and directly beneath the solenoid/actuator of the sprinkler. It is important that the **LOCATION OF THE SPLICES REMAIN CONSISTENT** through out the entire course. **DO NOT TAPE** the splice assembly to the Valve-in-Head sprinkler, as this would prevent removal of the sprinkler head from the riser without first digging down and un-taping the assembly. Otherwise, the solenoid coil can just be slipped off the core tube and the sprinkler then can be un-screwed from the riser. As with all splices, leave enough slack so as to be able to lift the assembly at least 1’-0” above the finish grade.

**FIRST** – Strip the outer jacket from each end of the two-wire communication cable, where you are going to install the decoder, near the lateral take-off and which will control the “block” configuration Valve-in-Head sprinklers. *Refer to previous area “Stripping the Outer Jacket”.* Then from each end of the conductors in the communication cable, strip approximately 5/8” of the PVC inner insulation from the conductors. *Refer to FIGURE: 3.7 shown previously,* for proper type of wire stripper to use.

**MAKING THE WIRE SPLICE** – When making an inline wire splice use a linesman’s pliers to gently twist one of the red insulated conductors to the other red insulated conductor and one of the black insulate conductors to the other black insulated conductor. Place no more than three or four twists in the wire. Twisting the wires in excess can fracture the conductors. *Refer to FIGURE: 3.8 shown previously.*

**WIRING OF DECODER INPUT & OUTPUT WIRES** – The **FD-601** decoder shall be wired into the Two-“Wire communication path at this lateral take-off location.

**DECODER INPUT WIRING:** The two (2) **blue** input wires of the decoder connect into the Two-Wire communication path, one to the **RED** insulated wires of the Two-Wire cable and the other to the **BLACK** insulated wires of the cable. It does not matter which of the **blue** wires, from the decoder, connect to the **red** and which to the **black** wires of the two-wire cable. **In addition;** the two (2) **green** ground wires from the decoder should be attached to a ground rod at this location. Use 3-M DBR connectors for these splices. *Refer to FIGURE: 3.16 shown previously.*

**DECODER OUTPUT WIRING:** There are six (6) pair of output decoder wires from this decoder, a ***brown, red, orange, black, gray*** and ***white*** pair.. One pair are to be connected to the two solenoid wires coming from the solenoid coil of the first Valve-in-Head sprinkler of the six (6) Valve-in-Head sprinklers being controlled by this decoder. The second pair are to be connected to the two solenoid wires coming from the solenoid coil of the second Valve-in-Head sprinkler. The third pair are to be connected to the two solenoid wires coming from the solenoid coil of the third Valve-in-Head sprinkler. The fourth pair are to be connected to the two solenoid wires coming from the solenoid coil of the fourth Valve-in-Head sprinkler. The fifth pair are to be connected to the two solenoid wires coming from the solenoid coil of the fifth Valve-in-Head sprinkler. The sixth pair are to be connected to the two solenoid wires coming from the solenoid coil of the sixth Valve-in-Head sprinkler. The maximum wire run between the decoder and any of the Valve-in-Head sprinklers ***must not exceed 328 feet.*** In order to make these connections it is necessary to splice a pair of 14-1 wires into each of the decoder output pair of wires. In order to keep the wires identified for each of the sprinklers, use a different color of wire for each of the pairs. Take one of the wires in the one 14-1 pair and one of the ***brown*** decoder output wires and hold them parallel to each other. Using your fingers or a linesman's pliers, twist the two wires together. ***Use a CLOCKWISE direction in making the twist so that in applying the wire nut it will not cause the wires to "un-twist".*** Use a 3-M DBY connector for this splice. The other wire of this pair and the other ***brown*** decoder wire shall be spliced together in the same manner. Repeat this same process for the wires in the second, third, fourth, fifth and sixth 14-1 pair of wires and to the two ***red, orange black, gray*** and ***white*** decoder output wire pairs. One pair of these six (6) pair of wires, will run the distance between the decoder and the first Valve-in-Head sprinkler of the block. The second pair of wires will run the distance from the decoder to the second Valve-in-Head sprinkler of the block. The third pair of wires will run the distance from the decoder to the third Valve-in-Head sprinkler of the block. The fourth pair of wires will run the distance form the decoder to the fourth Valve-in-Head sprinkler of the block. The fifth pair of wires will run the distance from the decoder to the fifth Valve-in-Head sprinkler of the block. The sixth pair of wires will run the distance form the decoder to the sixth Valve-in-Head sprinkler of the block. ***Refer to FIGURE: 3.17 shown previously.***

**SPRINKLER SOLENOID WIRING:** At the first Valve-in-Head sprinkler, connect each of the wires, in the pair controlling this sprinkler, to the respective solenoid coil wires of the Valve-in-Head sprinklers. Again it does not matter which of the wires from the decoder connect to which wires of the solenoid coil as long as you keep the pairs straight. (It is suggested that different color of wires be used for each pair for easy identification.) Take one of the wires in the 14-1 pair and one of the wires from the solenoid coil and hold them parallel to each other. Using your fingers or a linesman's pliers, twist the two wires together. ***Use a CLOCKWISE direction in making the twist so that in applying the wire nut it will not cause the wires to "un-twist".*** . Place a wire nut on the splice and then insert the splice into a ***3-M DBY*** connector, making sure you insert it into the connector as far as possible, and then snap the cap securely in place. ***Refer to FIGURE: 3.10 shown previously and also FIGURE 3.16 shown previously.*** Repeat this procedure for the second wire of this pair and the remaining solenoid coil wire.

At the second Valve-in-Head sprinkler, connect each of the wires, in the pair controlling this sprinkler, to the respective solenoid coil wires of the Valve-in Head sprinkler. Follow the same

procedure as outlined immediately above. Do the same at the third, fourth, fifth and sixth Valve-in-Head sprinklers. The procedures for proper splicing of an inline splice apply to all of these splices.. It may be necessary to strip a small additional amount of the insulation from the wires of the solenoid coils to provide enough bare copper conductor to work with in making the splice. If this is a “retrofit” of an existing system, this wire can be installed with a vibratory plow or if it is a new piping network, the additional wire can be laid in the trench between the decoder location and the first, second, third and fourth Valve-in-Head sprinklers. Locate and install the wire in the trench, as specified earlier in this manual

**CHECKING THE WIRING** – After you have made all the decoder output wire splices, at the solenoid coils at each of the Valve-in-Head sprinklers but before connecting to the decoder, check the resistance, at the decoder, using an OHM meter to measure the resistance to make sure the wires are connected to the solenoid properly. You should have approximately **24 to 29 Ohms** of resistance. For a proper installation you need to know which pair is connected to which Valve-in-Head sprinkler on the lateral. Mark or Tag each pair accordingly for future reference.

**RECORDING OF DECODER ADDRESS CODE** – At this point, record the four or five digit decoder address codes, for this decoder. (Remember that there are SIX (6) ADDRESSES for this decoder). You must not only identify the correct address code but also indicate which of the Valve-in-Head sprinklers the address is controlling. This data needs to be recorded on either a “Start-Up Work Sheet” and/or on a drawing of the irrigation system layout for the course, making sure you identify the proper location in the field for this decoder and of the sprinklers. This data will need to be on the “Start-Up Work Sheet” along with all the other necessary information to do the initial data entry into the computer. The decoders can be installed in any random address code order and do not need to be installed sequentially. The important thing is to accurately record the address code for the proper decoder and to properly identify the corresponding sprinkler this address will control.

## **Surge Protection and Proper Grounding of the Central Equipment of the Decoder System**

*Proper Surge Protection and Proper Grounding of the Decoder System Is Key to the Long and Trouble Free Operation of your System.*

In order to provide a reasonable level of surge protection at a realistic and acceptable cost, it is recommended that the following guidelines be followed in the installation of the Rain Bird Decoder control system. Special attention needs to be giving to proper protection of the Central Control Equipment and also of the various field decoders and other devices that make up the complete system. Special attention and care should be taken in regard to the furnishing of the recommended surge protection devices and the installation of these devices. Also, of equal importance are the proper grounding of the surge protection devices and the proper grounding of the equipment itself. **For these devices to remain effective it is absolutely necessary to properly maintain GOOD grounds for these devices and the equipment.** Therefore, this requires periodic checking of the grounds with a ground measuring instrument and the proper maintenance of the grounding networks at all times. *The importance of this cannot be overstressed and should not be overlooked as a standard maintenance procedure of your system.*

**\*SEE ADDENDUM FOR LDI & SDI**

**MDI DECODER SYSTEM INTERFACE UNIT SURGE PROTECTION** – For surge protection of the MDI Unit (Decoder Interface Unit) install a Rain Bird Model SUP-210 Surge Arrestor (which is included with the MDI unit) on the communication output of this unit and before the communication wires connects to the LTB (Line Termination Box). *Refer to FIGURE: 4.1 shown below.*

The 3-wire plug on the wire pigtail of the SUP-210 unit shall be plugged directly into the output port of the MDI unit, which is marked **“LINE”**. The Yellow & Green striped ground wire with spade lug shall have the spade lug connected to the screw on the MDI unit. **Be careful to be sure that this lug is securely tightened to the cabinet of the MDI unit and that the spring washer is still there.** *This should also be periodically checked to be sure that it is still tightly connected to the cabinet.* Good physical contact of the spade, on this ground wire, with the cabinet of the MDI, is essential to provide proper surge protection.

Connect the communication wires to the 3-wire plug on the outlet end of the SUP-210 Surge Arrestor and extend them over and connect them to the terminals #4, #5 & #6 on the LTB-210 (Line Termination Box). *Refer to FIGURE: 4.1 shown below.*

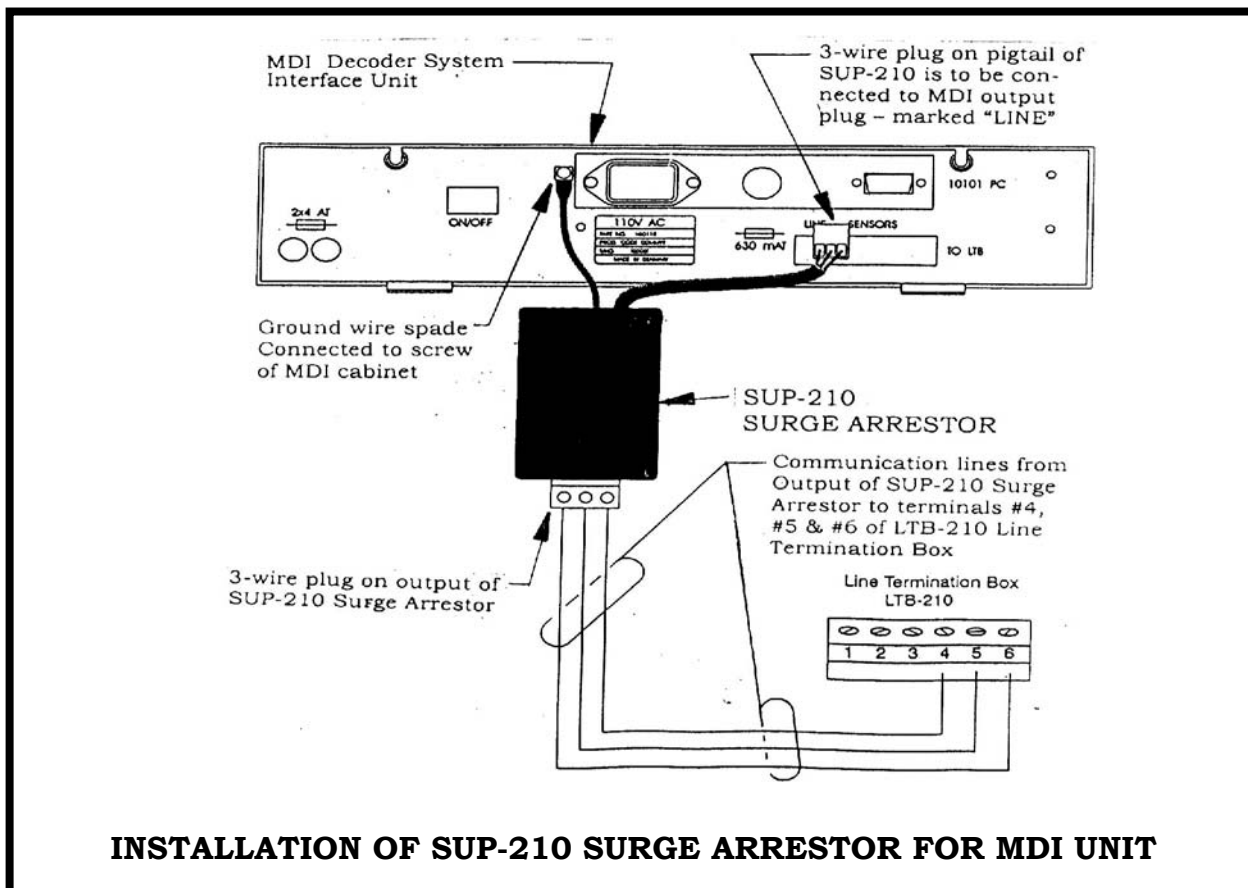

**FIGURE: 4.1**

**MAINTAINING A GOOD GROUND:** The success and the level of protection that will actually be realized from the various surge arrestor devices is dependent upon the equality of grounding that is achieved and MAINTAINED. Proper grounding is required to allow all components to go to the same potential voltage level. Unless the surge arrestor can discharge the surge to earth ground, it is ineffective in preventing the surge voltage from entering the electronic components and damaging them. The surge will take the least path of resistance and electronic components offer very little resistance. Therefore, the resistance of the path to earth ground for the surge arrestors must be as low as possible. Anything greater than **15Ω (Ohms)** is ineffective and for greatest effectiveness the resistance to ground should be **5Ω (Ohms) or less**, if at all possible.

In cases where a surge or high potential is induced on one area of the system it is important that other areas also go to this same potential. This is in order to avoid surge damage occurring from the surge going from the high potential area to the low potential area. This is accomplished again by the grounding system providing the necessary path to let both areas go to the same potential level.

## **Central Control Equipment Grounding Network**

Before any of the Central Control Equipment is installed and particularly before it is connected to the field wiring, it is necessary to install a ground grid consisting of four (4) 5/8" dia. x 8'-0" long, copper clad ground rods. *Refer to FIGURE: 4.2 shown below.* The purpose of this grid is to provide a path to ground for any electrical surges that may try to enter the central equipment. The grounding grid resistance must not exceed **15Ω (Ohms)** or it will not be effective in providing the necessary path to earth ground. The most effective ground grid protecting central equipment should have a resistance of **5Ω (Ohms)** or less, if at all possible. This resistance level will not be obtained when the grid is first installed but is the objective after a period of time and when the central equipment is ready to be installed and/or connected to the field. Upon initial installation the ground rods will not have had a chance to make good contact with the earth. Therefore, we recommend that the grid be installed four to five weeks prior to the central equipment being connected to the field. While nothing can protect against a direct lightning strike, grounding effectiveness goes down as resistance goes up. Just prior to connecting of the central equipment to the field, it is recommended to test the ground grid and then at a very minimum to test it at least once a year. In the more lightning prone areas, it would be prudent to check the grounds several times a year at minimum.

## **The Central Grounding Grid Layout**

Directly below the point at which your field wiring or communication cable will enter the building, excavate an 18" x 24" opening 15" deep, in which a jumbo rectangular valve box will be set on a 3" minimum layer of gravel (to provide drainage). If at all possible the Freedom

System antenna should also be mounted above the point at which the field wiring or communication cable will enter the building. In this way the same grounding grid can be used for grounding of the antenna and the coaxial cable surge arrester. Orient this opening with the 18" side closest to the building. In the center of this opening, drive a ground rod so that the top is 6" below the finish grade (this will be ground rod "A" as shown in **FIGURE: 4.2**).

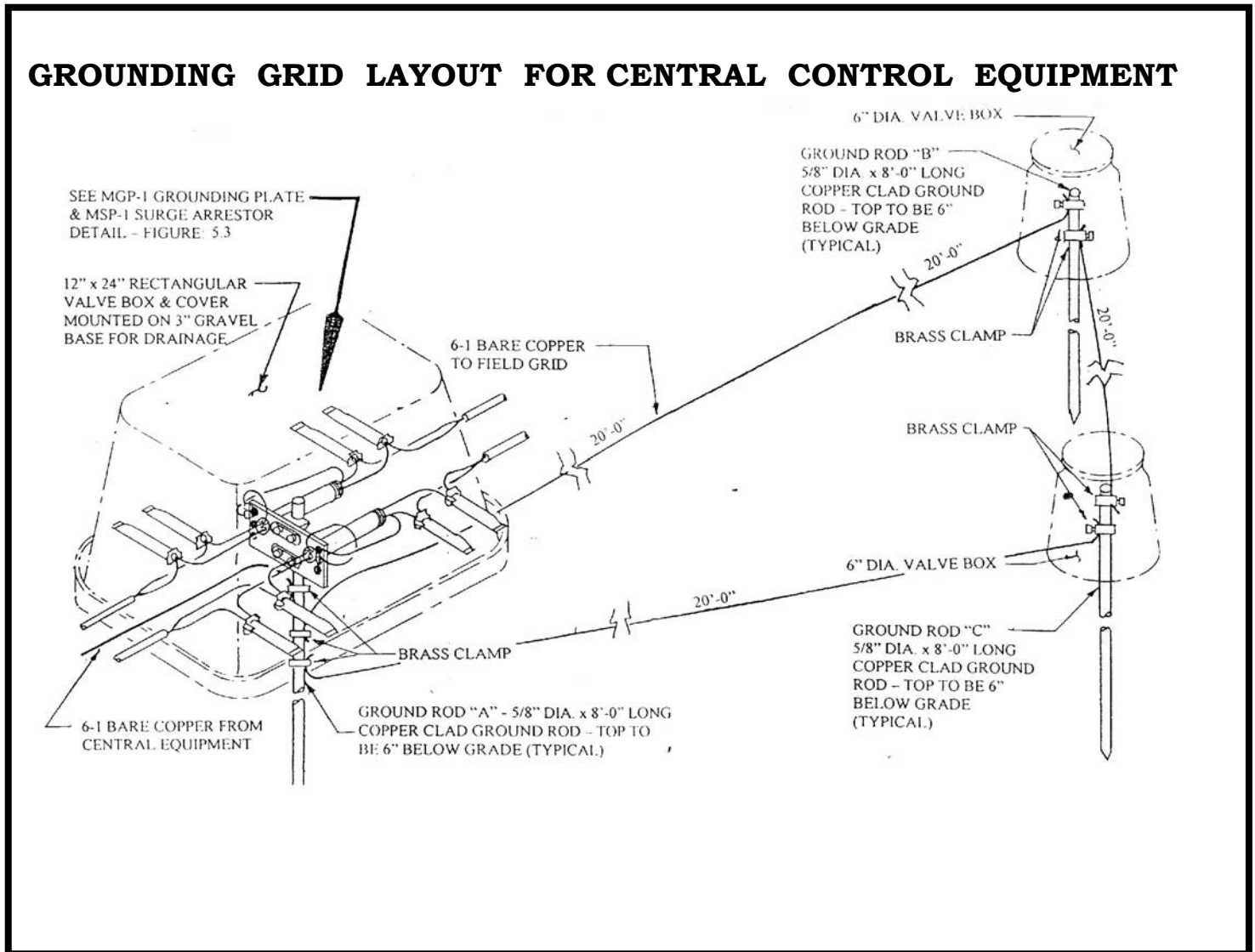

**FIGURE: 4.2**

Using a measuring tape, mark a point at least 20'-0" (6 meters) away from the rod you have driven closest to the building. This is the point at which ground rod "B" shall be driven. From this ground rod "B", carefully lay out a 20'-0" (6 meter) equilateral triangle to form the ground grid. If possible, locate these rods in a wetted area away from nearby trees. It may be necessary to go further than 20'-0" (6 meter) but that is acceptable. *Refer to FIGURE: 4.2 shown above.*

**PREPARATION OF VALVE BOX** – Before installing the valve box in the ground, with a 3/8" bit, pre-drill a single hole in the back center of the valve box, in the side away from the building and about 8" (200 mm) up from the bottom. Two #6 (10mm<sup>2</sup>) bare copper ground wires will be run through this hole to the two ground rods ("B" & "C"), of the field ground grid (*Refer to FIGURE: 4.2 shown above*). On the end of the valve box that will be closest to the building, pre-drill a single 3/8" hole in the center and about 8" (200 mm) up from the bottom. The bare copper ground wire from the Line Termination Box and/or central equipment will be run through this hole. If you will have more than one ground wire coming from the central equipment – drill the number of 3/8" holes that will be required for each of the ground wires, to each side of the center hole. Place a minimum of 3" (75 mm) of gravel in the bottom of the hole you have dug for the valve box and set the valve box so that the top is even with the finish grade.

**FIELD GROUND GRID INSTALLATION** – At the locations for installing ground rods "B", & "C", excavate a 12" (300 mm) diameter hole, about 10" (250 mm) deep. In the center of each of these holes, drive a 5/8" dia. x 8'-0" long copper clad ground rod so that the top is 6" (150 mm) below the finish grade. At ground rod "B" & "C", slide on 2 brass clamps on each rod. Connect ground rod "B" to ground rod "C" using a piece of #6 (10mm<sup>2</sup>) or larger bare copper wire. Connect ground rod "C" to ground rod "A" using a piece of #6 (10mm<sup>2</sup>) or larger bare copper wire. Connect ground rod "B" to ground rod "A" using a piece of #6 (10mm<sup>2</sup>) or larger bare copper wire. The wires are to be a minimum of 12 inches (300mm) below the finish grade. Make all wire connections to the rods with a separate brass clamp. **DO NOT** attempt to place more than one wire in a given clamp because there is a potential for poor connections, either at initial installation or over a period of time. Place a 6" diameter valve box over each of the two ground rods "B", & "C" to provide access to the clamps for maintenance checking for tightness and also providing a moist soil environment for better grounding conditions.

## **Caution !**

**When working with the #6 (10mm<sup>2</sup>) or larger ground wire, take care not to make any sharp bends or kinks in the wire at any point of its routing as this will increase its RESISTANCE to ground – thereby decreasing the effectiveness of your ground grid. All bends shall be long, smooth radii of as large a radius as possible.**

**INSTALLATION OF MGP-1 AND MSP-1 ASSEMBLY** – Each MGP-1 Grounding Plate Assembly can accommodate two (2) MSP-1 Surge Arrestors. Each Two-Wire communication path or cable leg coming to the central location from the field decoders, will be spliced to an MSP-1 Surge Arrestor assembly. The MGP-1 Grounding Plate assembly has two (2) threaded openings for accepting MSP-1 Surge Arrestors. For example, if there are two (2) Two-Wire paths, then one (1) MGP-1 Grounding Plate assembly and two (2) MSP-1 Surge Arrestors will be needed (one for each wire path). For three (3) or four (4) Two-Wire paths, two (2) MGP-1 Grounding Plate Assemblies and the corresponding number of MSP-1 Surge Arrestors to match the number of wire paths that will be needed.

**ASSEMBLY OF MGP-1 AND MSP-1 UNITS** – The first step is to slide two (2) brass clamps on to the 5/8” dia. x 8’-0” long copper clad ground rod “A”, that you have previously driven into the ground. Next mount the MGP-1 Grounding Plate assembly on ground rod “A”, near the top of the rod, using the two (2) “U-Bolt” clamps and spacers provided. Coat the threads on the “U-Bolt” clamps with Anti-Seize or other similar compound. The two ends of the MSP-1 Surge Arrestor are labeled “EQUIP” and “FIELD” respectively. From each end of the MSP-1 there is a black wire, a red wire and a green (ground) wire. On the end of the green ground wire, from each end of the MSP-1, crimp a small open end spade lug. Coat the threads of the MSP-1 on the end labeled “EQUIP” with Anti-Seize or other similar compound. Push the three wires, from this end of the MSP-1, through one of the threaded openings of the MGP-1 Grounding Plate assembly. Firmly screw the MSP-1 into the threaded opening. Repeat this same procedure for each of the other MSP-1 Surge Arrestors, if there are more than one Two-Wire path involved with your installation. Coat the threads of all ground screws on the MGP-1 Grounding Plate assembly with Anti-Seize or other similar compound. Loosen one of the ground screws on the MGP-1 and slide the spade lugs, from both green ground wires coming from each end of the MSP-1 Surge Arrestor, under the screw and firmly tighten. **Refer to FIGURE: 4.2 and FIGURE: 4.3 for further details.** Repeat this same procedure for the green ground wires from the other MSP-1 Surge Arrestors that you may have involved with your system – crimping on the open end spade lugs and firmly connecting them to one of the ground screws on the MGP-1 Grounding Plate assembly.

**CONNECTING TWO-WIRE COMMUNICATION PATHS** – The Two-Wire communication paths coming from the field decoders need to be connected to the MSP-1 Surge Arrestors that you have mounted in the MGP-1 Grounding Plate assembly.

## Caution !

**It is very important that you keep track of which incoming leg of the Two-Wire Communication cable goes to which portion of the golf course. As you proceed with the central installation, mark the wire with a permanent marking pen or other type of permanent marking tag, indicating what area or holes of the course it is serving.**

### WIRING OF TWO – WIRE COMMUNICATION PATHS COMING FROM FIELD

DECODERS – Run the incoming legs of the Two-Wire Communication paths, coming from the decoders in the field, through the large opening in back of the valve box (the side toward the field). Leave a foot or more of slack in the cables, inside the valve box, so that connections can be easily brought to grade level for easy inspection and working on them if required in the future. Each of the individual Two-Wire cables shall be connected to one of the MSP-1 Surge Arrestors on the end labeled “FIELD”. Connect the **RED** wire of the cable to the **RED** wire of the MSP-1 Surge Arrestor. Connect the **BLACK** wire of the cable to the **BLACK** wire of the MSP-1 Surge Arrestor. Use 3-M DBY or DBR direct burial splice kits for these connections. Use the splicing techniques as previously described. *Refer to FIGURE: 4.3 as shown below.* Repeat this procedure for each of the Two-Wire cables that you have coming from the field decoders.

## CENTRAL LOCATION - INSTALLATION DETAIL FOR MGP-1 GROUNDING PLATE ASSEMBLY, MSP-1 SURGE ARRESTORS AND CENTRAL GROUNDING

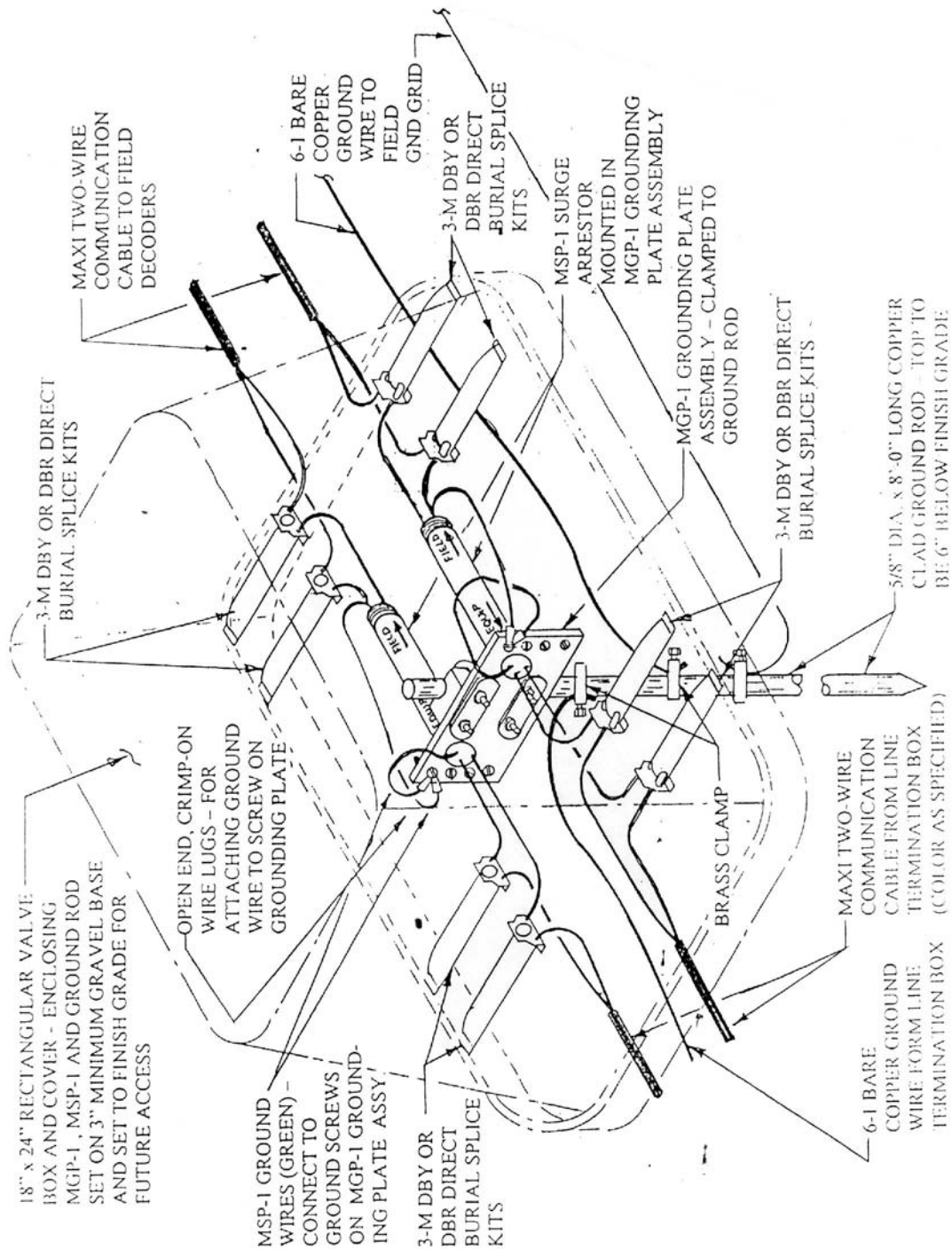

**FIGURE: 4.3**

## **WIRING OF TWO-WIRE COMMUNICATION PATHS COMING FROM THE LINE TERMINATION BOX AT THE CENTRAL LOCATION - Run**

the Two-Wire communication cables coming from the Line Termination Box through the large opening in the side of the valve box that is closest to the building. Leave a foot or more of slack in the cables, inside the valve box, so that connections can be easily brought to grade level for easy inspection and working on them if required in the future. Each Two-Wire cable shall be connected to one of the MSP-1 Surge Arrestors on the end labeled "EQUIP". Connect the RED wire of the cable to the RED wire of the MSP-1 Surge Arrestor. Connect the BLACK wire of the cable to the BLACK wire of the MSP-1 Surge Arrestor. Use 3-M DBY or DBR direct burial splice kits for these connections. Use the splicing techniques as previously described. **Refer to FIGURE: 4.3 as shown above.** Repeat this procedure for each of the Two-Wire cables that you have coming from the Line Termination Box.

## **CONNECTING GROUND WIRES AT CENTRAL LOCATION -**

Connect a #6 or larger bare copper ground wire to one of the brass clamps you have placed on ground rod "A", at the central equipment location. Run this ground wire through the 3/8" diameter drilled hole in the back of the valve box (the side toward the field). Extend the wire over to ground rod "B" and connect it to the rod by using one of the three (3) brass clamps you have placed on the rod previously. **Refer to FIGURE: 4.1 and FIGURE: 4.2.** Run a #6 or larger bare copper ground wire, from the ground terminal lug in the Line Termination Box, through the 3/8" drilled hole in the end of the box that is toward the building. Connect the ground wire to ground rod "A" using the other brass clamp you have previously placed on this rod. Remember not to make any sharp bends or place any kinks in these ground wires as this will only add resistance to the ground network and reduce the effectiveness of the grounding system. All bends shall be long smooth radii of as large a radius as possible.

You have now completed the installation of the Surge Protection of the Two-Wire Paths coming from the field decoders and going to the Line Termination Box. In addition the proper grounding network has also been accomplished to provide proper effectiveness of the surge devices.

**NOTE !** For detailed installation instructions and drawings for the MDI, LDI, SDI Interface Units and the Line Termination Box – **refer to the ADDENDUM AT THE END OF THIS MANUAL.**

## **POWER SUPPLY (120 VAC) SURGE PROTECTION –**

The 120 VAC Power Supply is the electrical circuit that will be used to supply power for the Central Computer, MDI Interface Unit, Monitor, Printer, etc. for all the central equipment required. The transformer in the MDI will supply power to the decoders and solenoids in the field over the two-wire path.

As shown in **FIGURE: 4.4** below, surge protection is provided by wiring into the circuit supplying the central equipment (at the main electrical panel) a **Model Z-2 “ZAP TRAP” Power Filter** surge arrester, as manufactured by Tyte-wadd Power Filters, Springfield, Missouri (417-887-3770).

The “ZAP TRAP” surge arrester shall be installed in the main electrical panel and wired into the circuit supplying the 120 VAC Power to the central equipment. The “ZAP TRAP” shall be grounded to the grounding buss of the main electrical panel. *Refer to FIGURE: 4.4 shown below.*

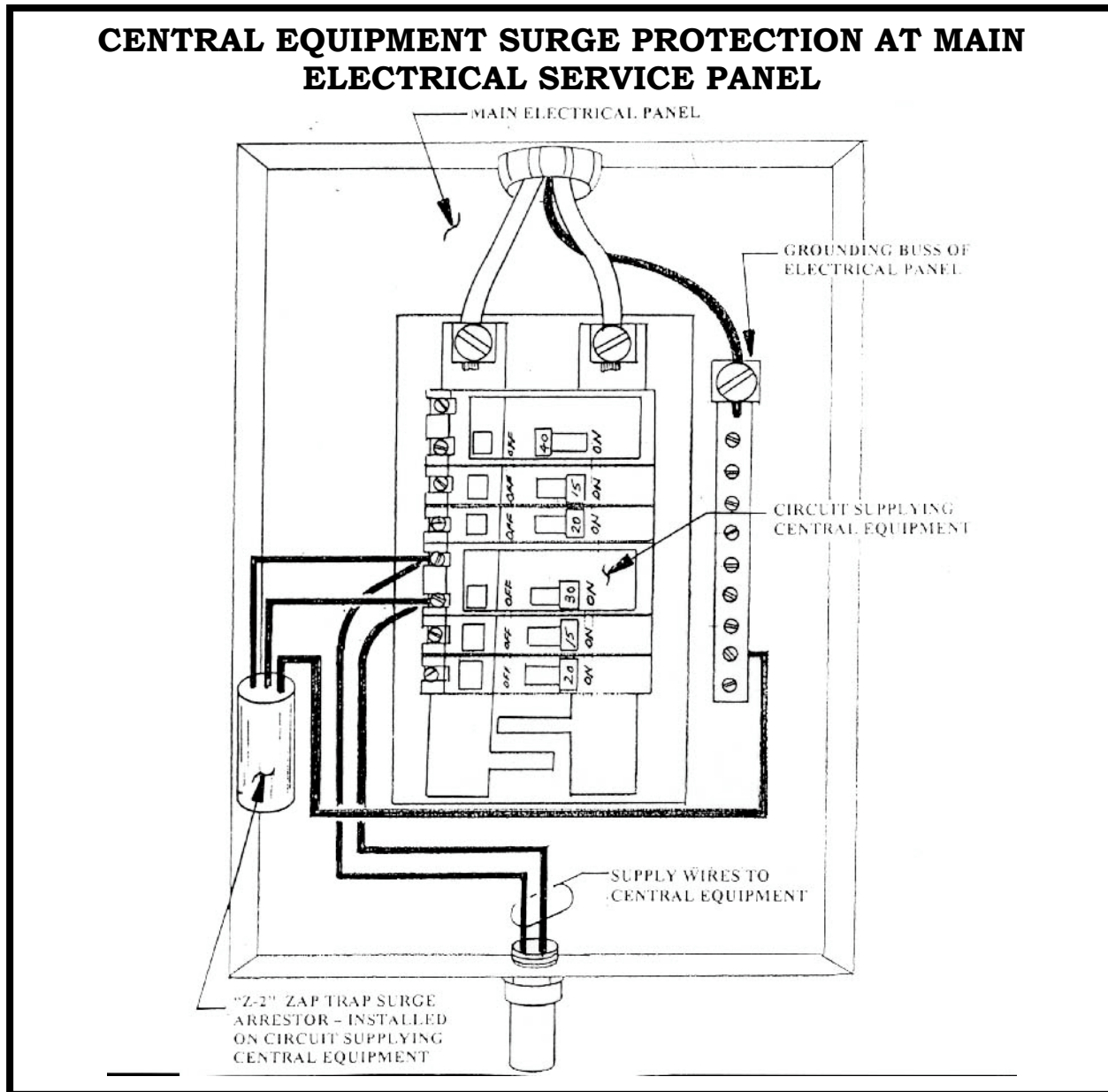

**FIGURE: 4.4**

**LTB-210 LINE TERMINATION BOX** – A Line Termination Box shall be installed at the central location and as near as possible to the Central grounding grid network as practical, but *not further than 90 feet from the MDI UNIT.* The Line Termination Box has surge protection devices built into it. From the center GROUND LUG – labeled “EARTH” it is necessary to install #6 , or larger, bare copper ground wire and run it out and connect it to Ground Rod “A” of the central grounding grid network. Refer to **FIGURE: 4.3 (previously shown)** and **FIGURE: 4.5 as shown below.** The ground wire shall be as straight and as short as possible. Avoid any sharp “bends” or “kinks” in the wire as these will only cause additional resistance to the network.

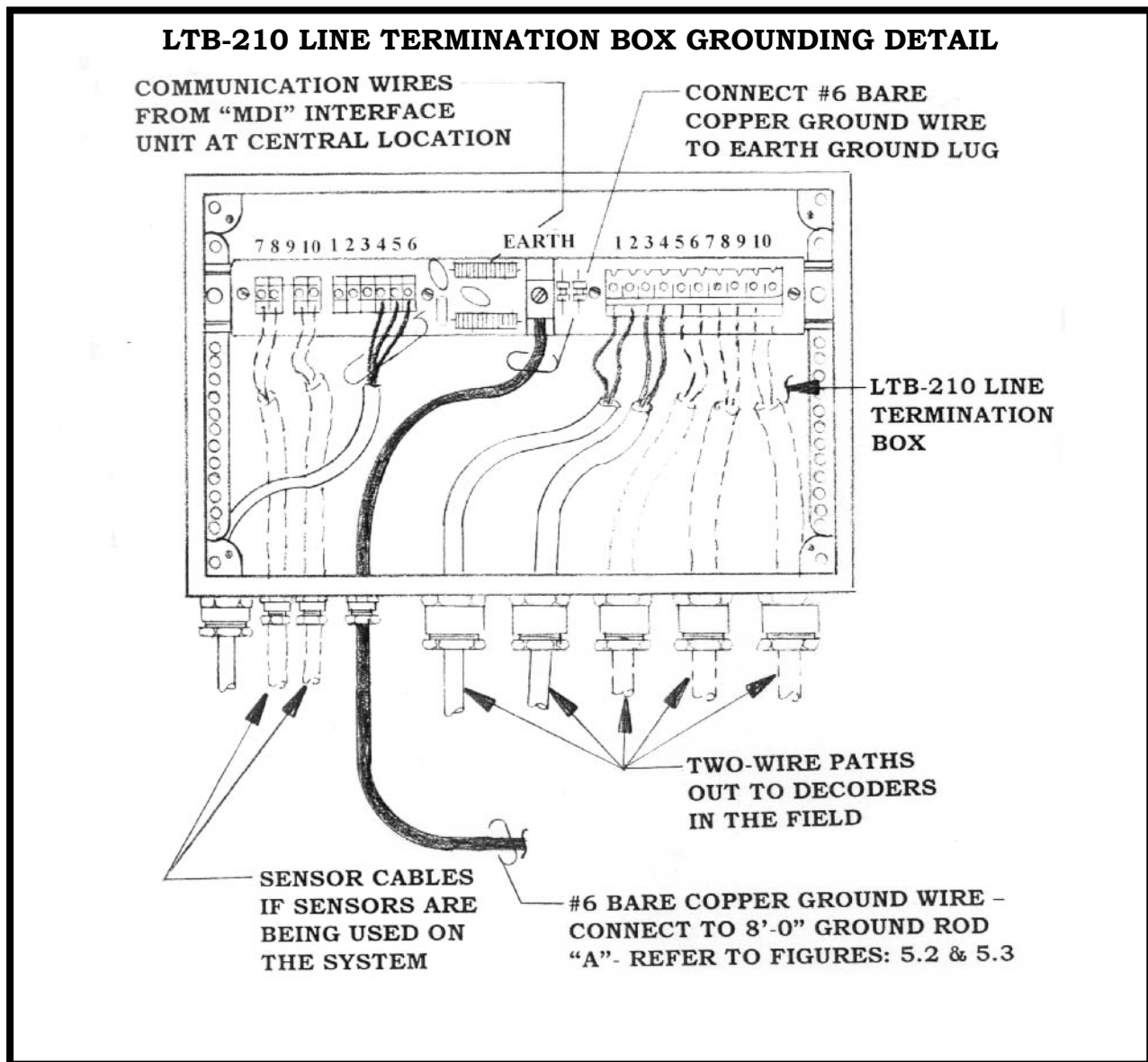

**FIGURE: 4.5**

## **Surge Protection and Proper Grounding of the Field Decoders, Solenoids and Communication Wire Paths**

*Proper Surge Protection and Proper Grounding of the Field Decoders, Solenoids and the Two-Wire Communication Paths is the Key to the Long and Trouble Free Operation of your System and the Minimal Loss of Decoders and Solenoids due to Lightning Surges on the System.*

### **PRIMARY SURGE PROTECTION FOR THE FIELD DECODERS AND THE FIELD SOLENOIDS ARE LSP-1 SURGE ARRESTORS -**

The LSP-1 Surge Arrestor, consists of several surge arrestor devices “potted” in a cylindrical plastic case ( the same case as is used for the FD-102 and the FD-202 except the case color is **YELLOW** rather than **BLACK** as used for the decoders.

#### **LSP-1**

The **LSP-1** surge arrestor has two (2) **BLUE** wires, which connect into the Two-Wire communication path at the decoder location. Polarity is not important so either blue wire may be connected – one to the **BLACK** wire of the Two-Wire path and the other to the **RED** wire of the Two-Wire path. There are also two (2) **GROUND** wires (Green in color), with the ground wire having the “closed eye” spade, to be securely connected to the core tube of the solenoid, on the Valve-in-Head rotor or on the Remote Control valve by means of a stainless steel nut threaded onto the core tube. The other ground wire shall be connected to a driven 5/8” Dia. x 8’-0” long copper clad ground rod, using a brass clamp to do so. *Refer to FIGURES: 5.1 thru 5.7 shown below.*

A minimum of 50 OHMS or less is required for the ground resistance to assure the LSP-1 surge arrester being effective. In most installations it will require at least an 8'-0" long ground rod to obtain 50 OHMS or less resistance. In some instances it may take three (3) 8'-0" rods in a triangular pattern, tied together below grade with #10 AWG or larger bare copper ground wire, to obtain 50 OHMS or less resistance. *It is absolutely necessary to obtain and maintain a ground resistance of 50 OHMS or less if the LSP-1 Surge Arrester is to be effective.*

**EXCEPTION** – In those situations, where the decoder **IS NOT** located next to the solenoid, the LSP-1 surge arrester shall be located at the decoder and the two (2) green **GROUND** wires shall both be connected to the 5/8" Dia. x 8'-0' copper clad ground rod, or one of the rods in the 3-rod ground grid, if it is required to get 50 OHMS or less resistance, and each attached by a separate brass clamp. **DO NOT ATTACH BOTH WIRES IN THE SAME BRASS CLAMP !** It is difficult to get the two wires to tightly secure to the rod, by using one clamp, and also the two wires are much more prone to come loose when using one clamp for the two wires. Thus the effectiveness of the ground is greatly diminished or perhaps lost altogether – thus no protection provided. Although it may be necessary to make the installation in this manner in some instances – it **IS NOT THE PREFERRED** method of installation nor the most effective method of installation. Therefore, when at all possible this method should not be used but rather the method, where the core tube of the solenoid is also grounded, should be used.

**NOTE !**

As mentioned above, wherever possible the decoder, for controlling a given valve-in-head rotor, as well as, for controlling the remote solenoid control valve for a battery system of sprinklers, shall be installed immediately adjacent to the solenoid actuator. In this way the LSP-1 Surge Arrester, with its grounding system can be such as to ground the solenoid core tube as well as the surge arrester itself. **THIS IS THE MOST EFFECTIVE SURGE PROTECTION for the Decoders and the Solenoids.**

**SURGE PROTECTION OF FIELD DECODERS AND TWO-WIRE COMMUNICATION PATHS** – Proper location of field decoder Surge Arrestors (LSP-1) and proper grounding of these devices can assure you of a reasonable amount of protection against damage from lightning strikes. Since each decoder system installation will be different, it is not possible to give specific detailed requirements for each. However, if some care is exercised and the following general guide lines are followed a reasonably protected system can be achieved.

**GUIDE LINES FOR LOCATION AND INSTALLATION OF LSP-1 SURGE ARRESTORS** – Although each layout will be different, the following should act as a guide in determining or estimating the number of LSP-1 surge arrestors required on your system.

- **9-HOLE** Golf Course: Approximately 20 to 30 LSP-1's.
- **18-HOLE** Golf Course: Approximately 40 to 60 LSP-1's.

### LSP-1 LOCATIONS

- **At a Dead End:** Whenever the two-wire path terminates in a “Dead End” - an LSP-1 Surge Arrestor shall be installed at the last decoder before the “Dead End”. If the “Dead End” is designed with an FD-401 or FD-601 decoder as the last decoder before the “Dead End”, which contains a built-in LSP-1 surge arrestor as an integral part of the decoder, this decoder and its built-in LSP-1 surge arrestor will be sufficient to provide adequate surge protection.
- **Along the Wire Path in a Block Installation:** Install an LSP-1 Surge Arrestor so that there are no more than eight (8) decoders between two (2) LSP-1 surge arrestors or there is no more than 500 feet between the LSP-1's, which ever is less, according to the installation guidelines given above. *Refer to FIGURE: 5.1 shown below.*
- **Along the Wire Path in a VIH Installation:** Install an LSP-1 Surge Arrestor, so that there are no more than eight (8) decoders between two (2) LSP-1 surge arrestors or there is no more than 500 feet between LSP-1's, which ever is less, according to the installation guidelines given above. *Refer to FIGURE: 5.2 shown below.*

**INSTALLATION OF LSP-1 SURGE ARRESTORS:** As outlined above, LSP-1 Surge Arrestors are installed along the Two-Wire communication path and also at “Dead Ends” of the Two-Wire path.

**LSP-1** installed along the Two-Wire path at an **FD-102** Decoder

LSP-1 Surge Arrestors shall be installed along the Two-Wire path as shown on the drawings and as required for adequate protection of the Decoders and Solenoids. Those LSP-1 Surge Arrestors that are being installed with an FD-102 Decoder shall be installed as shown in **FIGURE: 5.1** below.

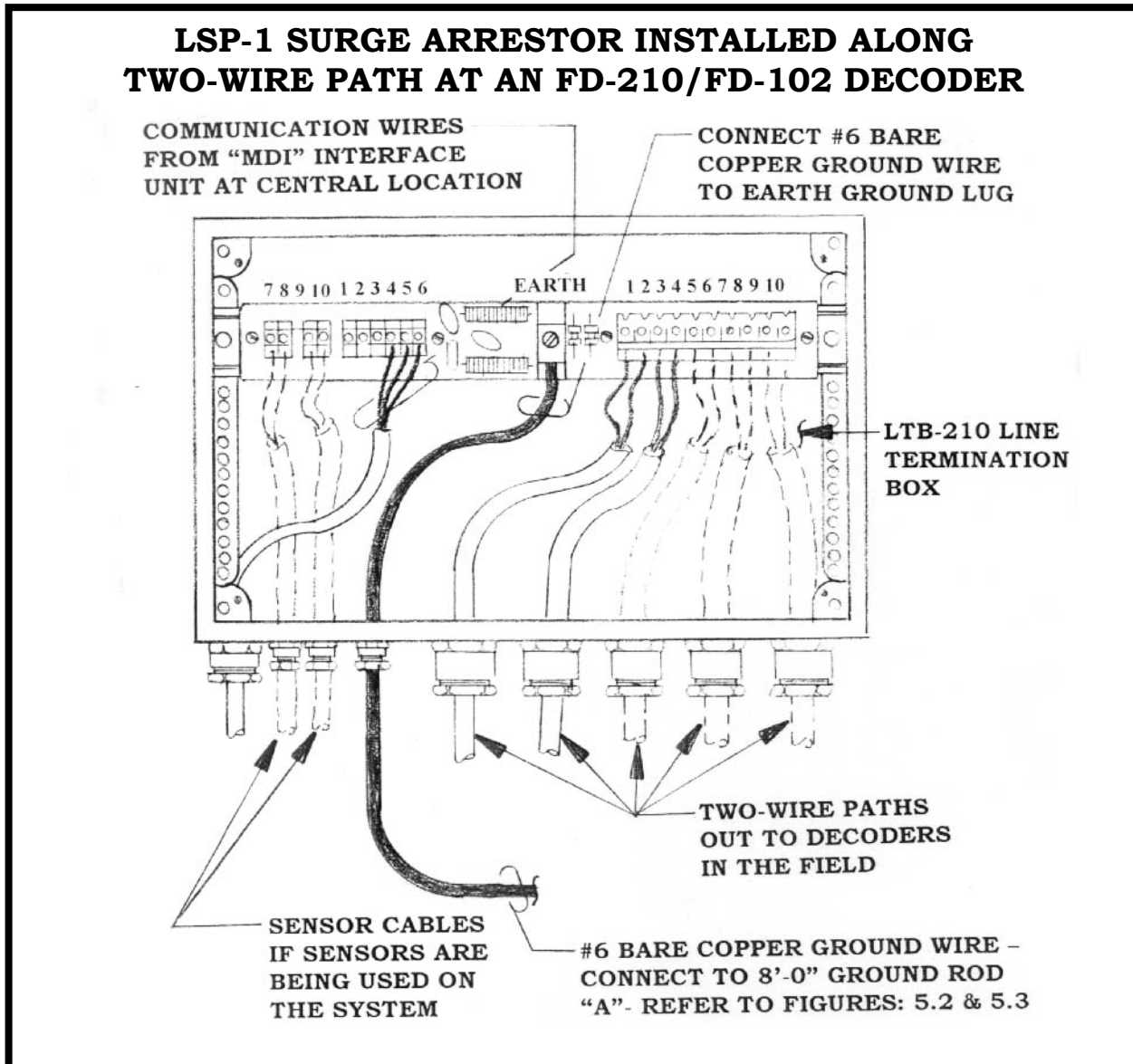

**FIGURE: 5.1**

**LSP-1** installed at a “Dead End” of the Two-Wire path at an **FD-102** Decoder.

An LSP-1 Surge Arrestors shall be installed at a “Dead End” of the Two-Wire path as shown on the drawings and as required for adequate protection of the Decoders and Solenoids. Those LSP-1 Surge Arrestors that are being installed with an FD-102 Decoder shall be installed as shown in **FIGURE: 5.2** below.

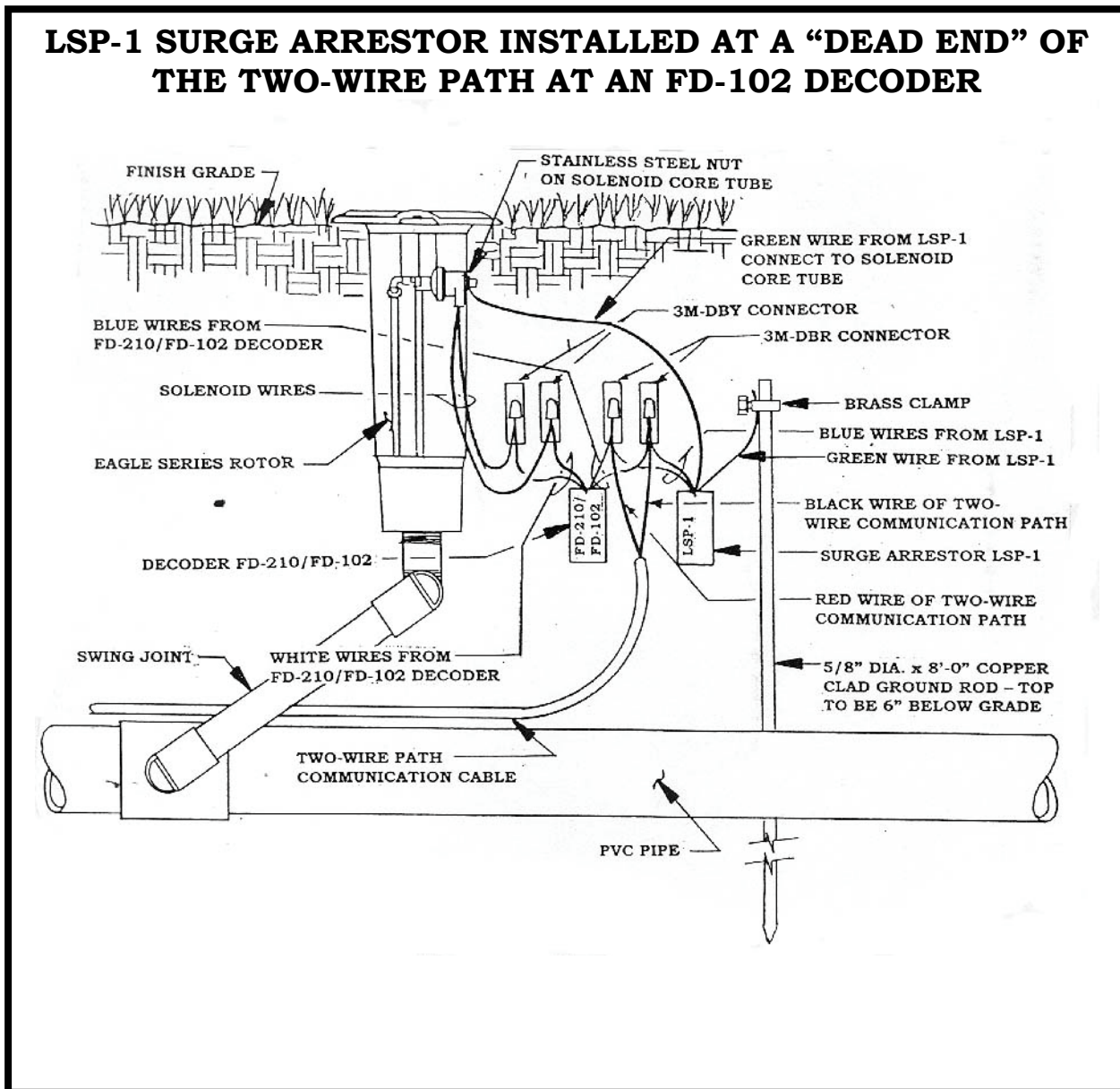

**FIGURE: 5.2**

**LSP-1** “built-in” an **FD-601** Decoder installed along the Two-Wire path. (FD-401 is similar)

The FD-601 Decoders have a “built-in” LSP-1 surge arrester. Those FD-601 Decoders along the Two-Wire path shall be installed as shown in **FIGURE: 5.5** below.

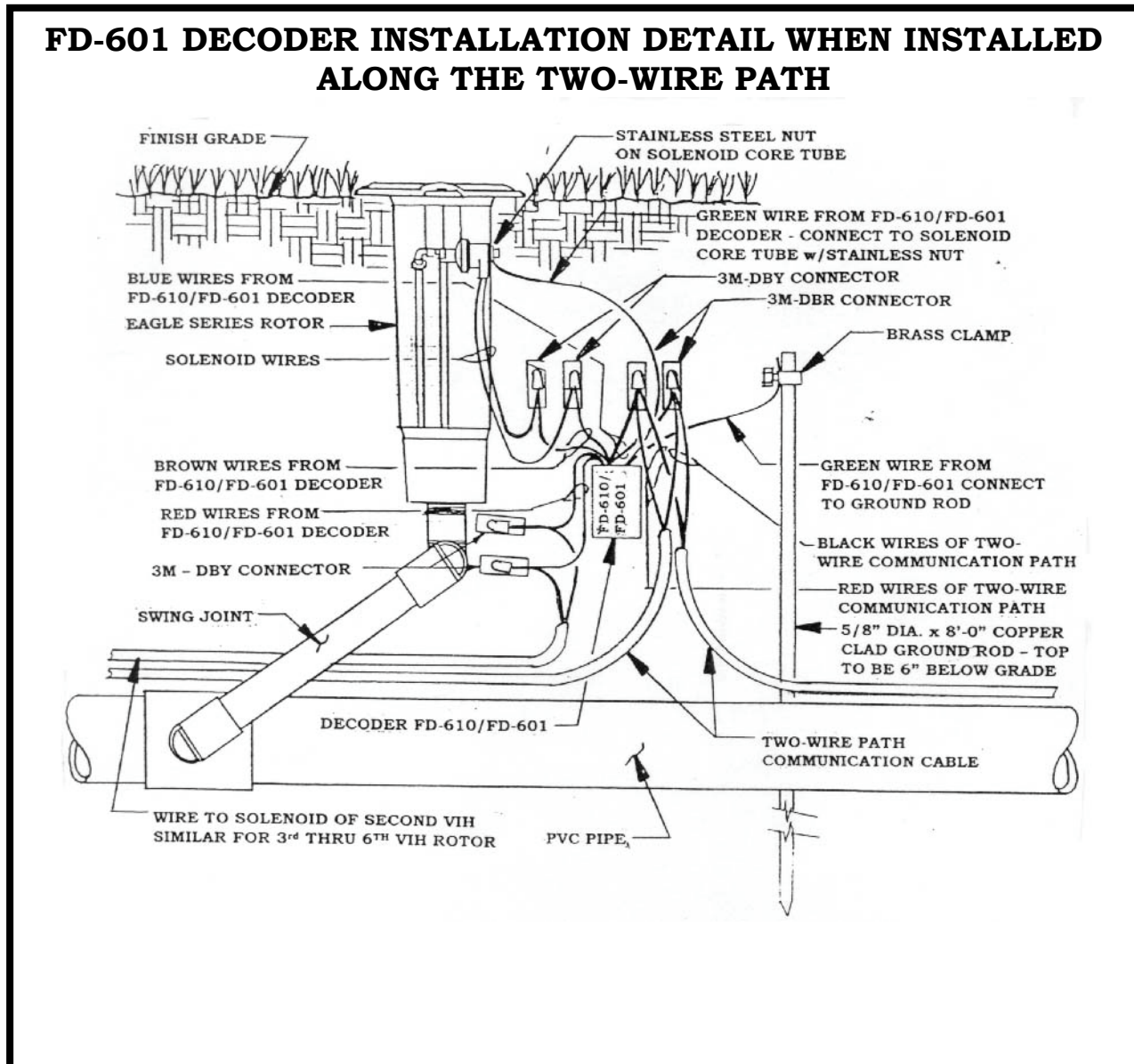

**FIGURE: 5.5**

**LSP-1** “built-in” an **FD-601** Decoder installed at the “Dead End” of the Two-Wire path. (FD-401 is similar).

The FD-601 Decoders have a “built-in” LSP-1 surge arrester. Those FD-601 Decoders located at the “Dead End” of the Two-Wire path shall be installed as shown in **FIGURE: 5.6** below.

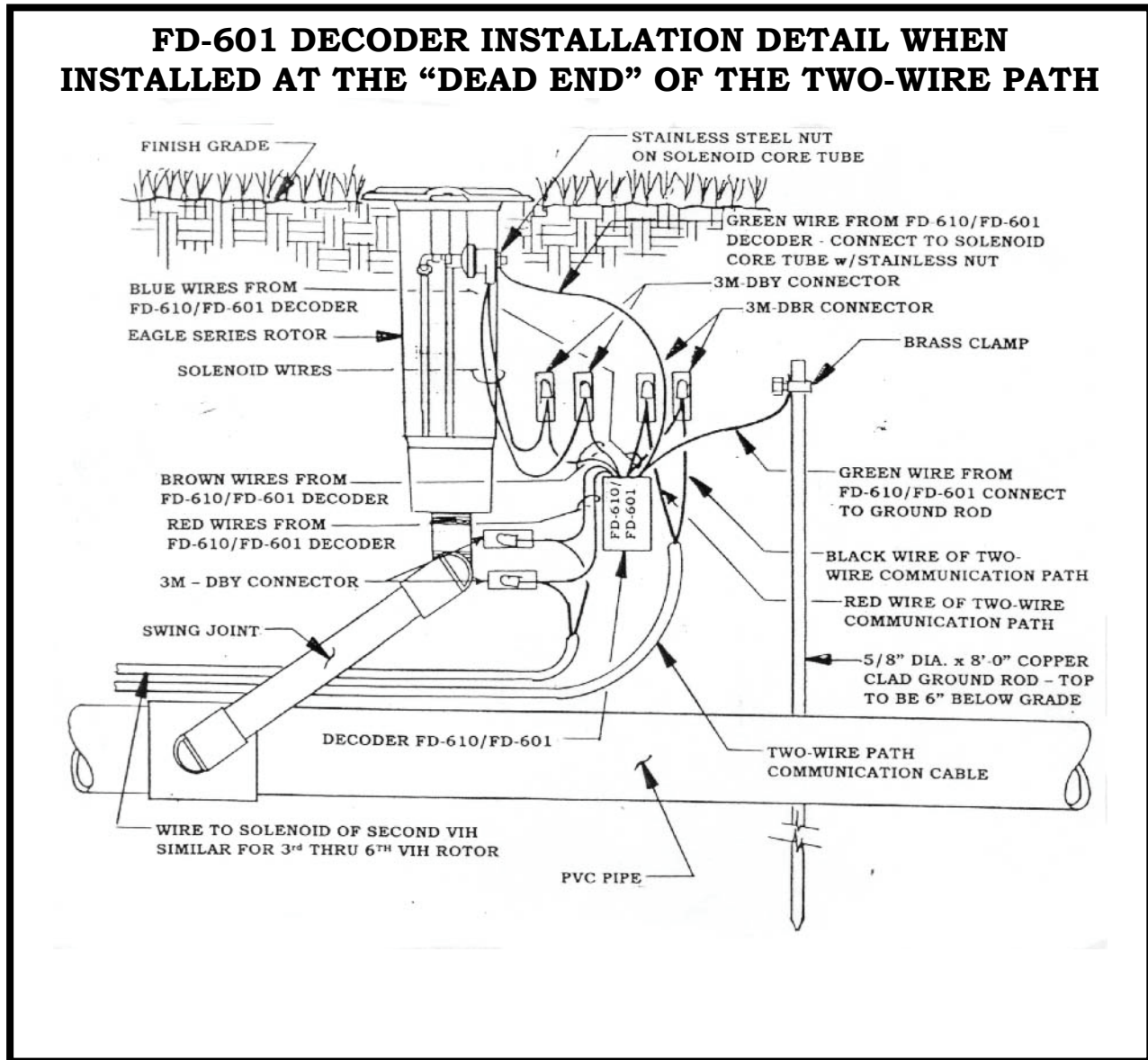

**FIGURE: 5.6**

**RECORD LOCATION OF ALL LSP-1 SURGE ARRESTORS** – It is extremely important to note on the “as-built” plans the location of all LSP-1 Surge Arrestors as this can greatly assist in future troubleshooting of the system. It is *strongly recommended to place the decoder and the LSP-1 surge arrester in a 10” diameter valve box*, which is buried 6” below grade and next to the valve-in-head sprinkler or remote control valve. *Refer to FIGURE: 5.7 shown below.* This will provide easy and quick access to the decoder and LSP-1 surge arrester, when troubleshooting the system.

**TYPICAL INSTALLATION DETAIL FOR ALL LSP-1 SURGE ARRESTORS TO BE PLACED IN A VALVE BOX**

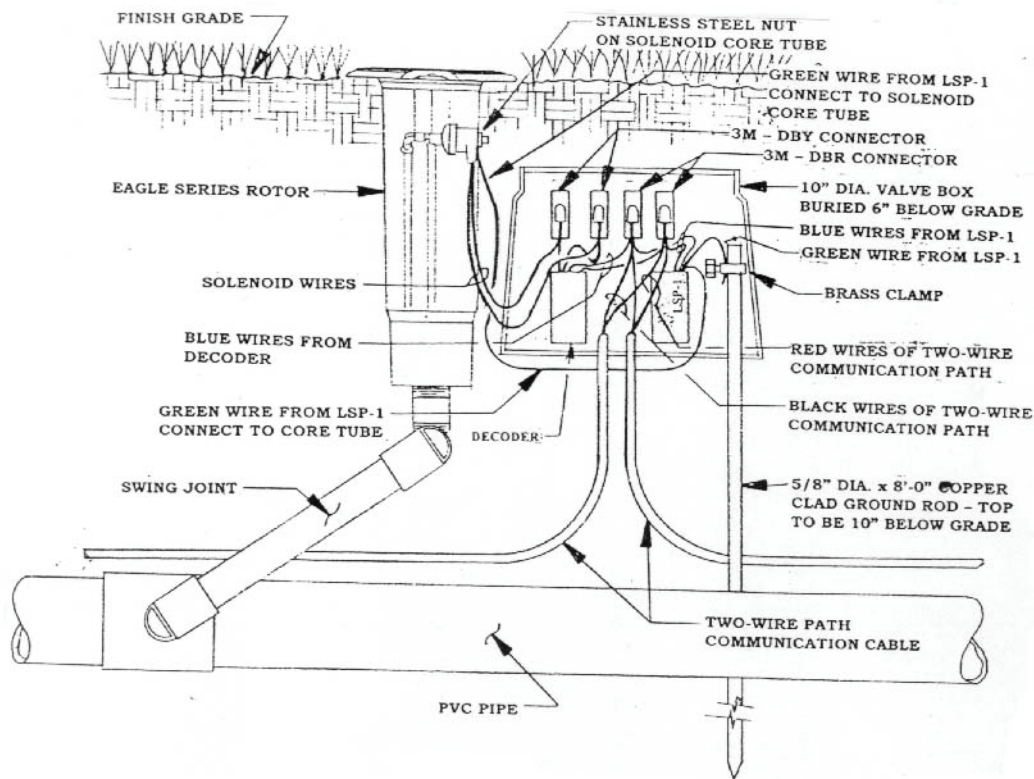

**FIGURE: 5.7**

## GUIDE FOR LOCATING LSP-1 SURGE ARRESTORS ON A SINGLE ROW, DECODER OPERATED, VALVE-IN-HEAD SYSTEM

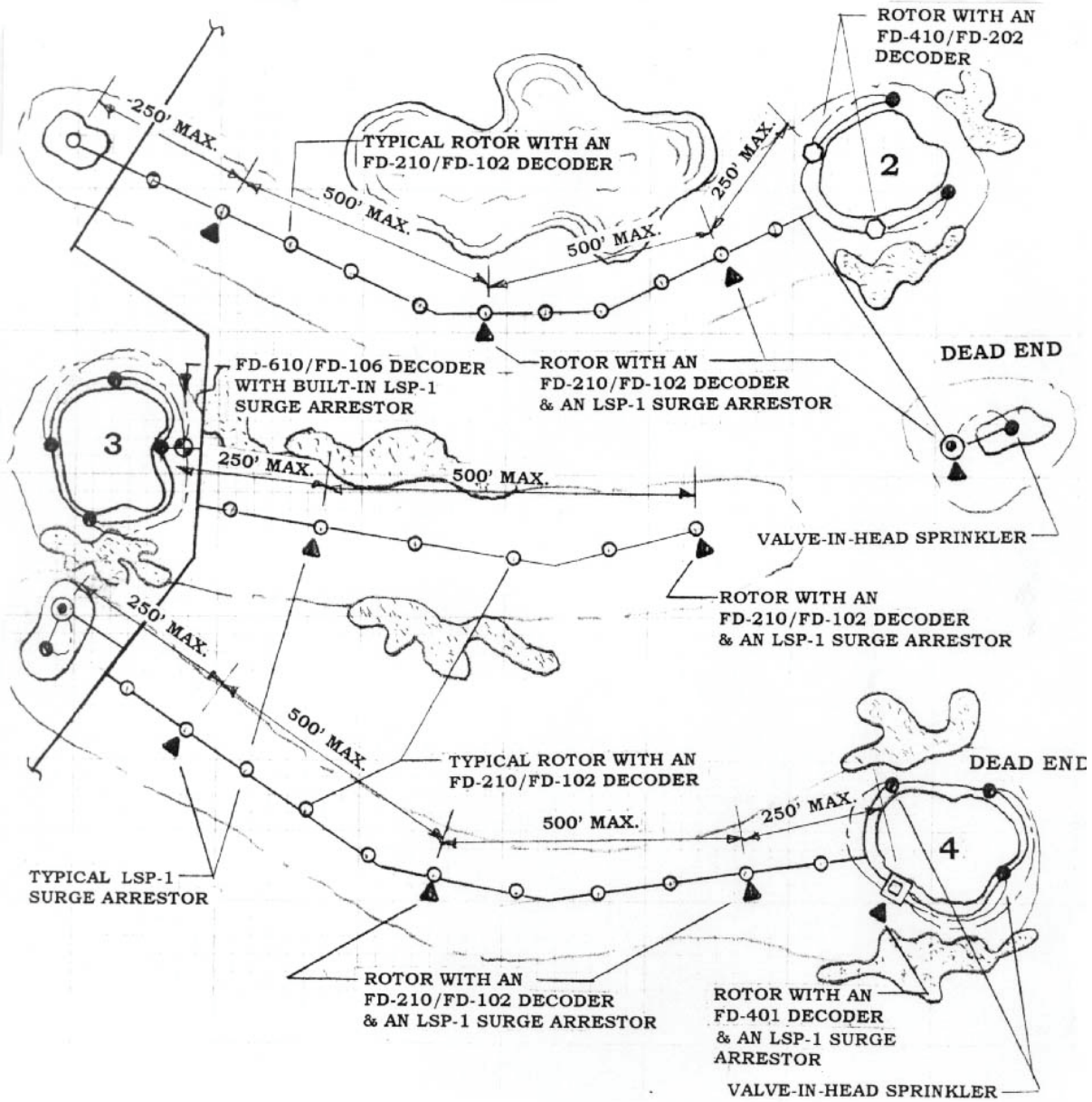

**FIGURE: 5.8**

# GUIDE FOR LOCATING LSP-1 SURGE ARRESTORS ON A TYPICAL BLOCK, DECODER OPERATED, VALVE-IN-HEAD OR REMOTE CONTROL VALVE SYSTEM

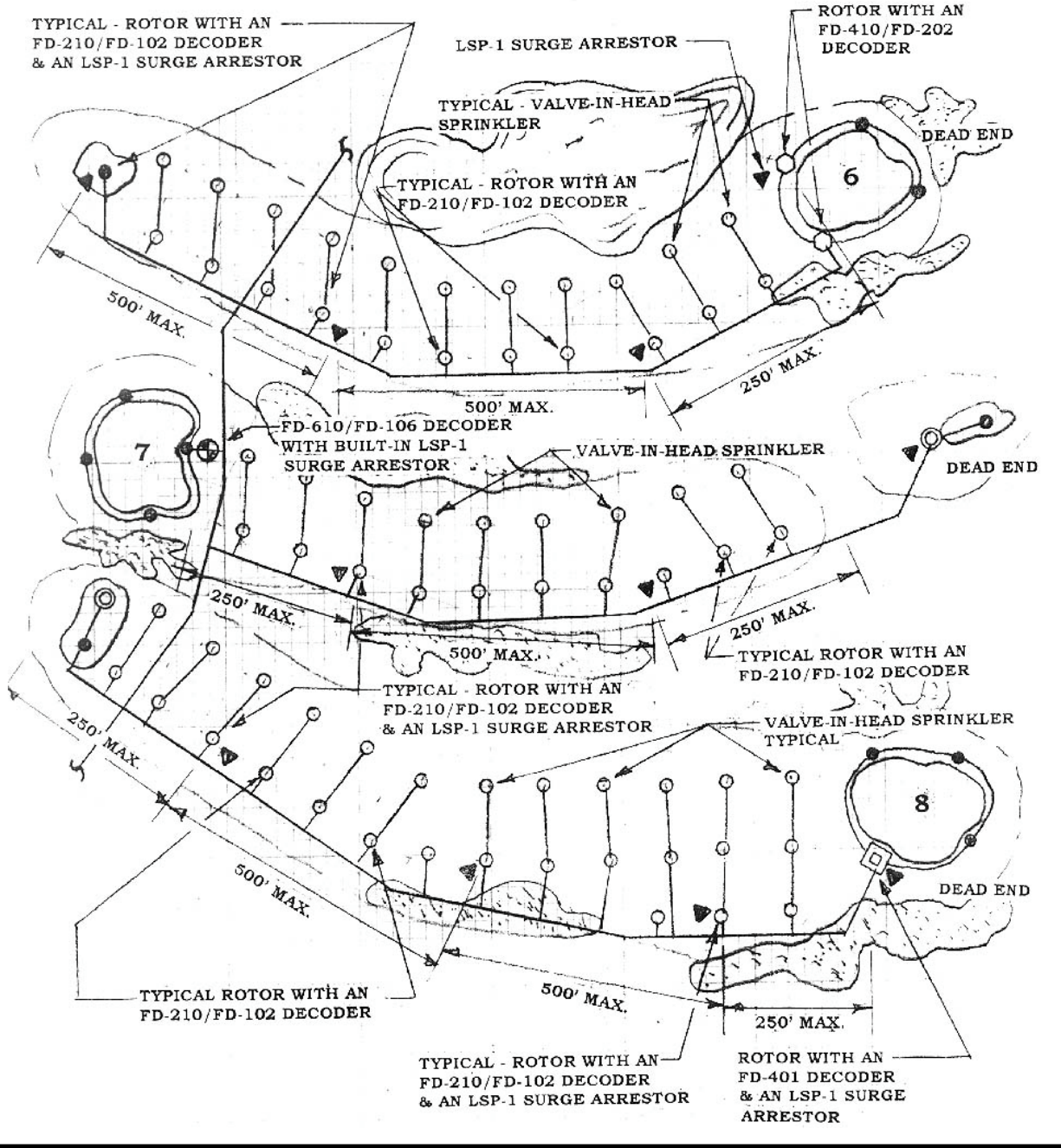

**FIGURE: 5.9**

## Programming the Decoder System

*The Following Programming Instructions Pertain to the Following Rain Bird Decoder Control Systems:*

*Stratus & Stratus II  
Nimbus & Nimbus II  
Cirrus*

The following programming procedure illustrates the necessary steps required to program the Decoder System, and is based on the Cirrus Control System. The other Stratus and Nimbus Control Systems program in a similar manner.

### Configuring the Decoder System:

The first thing you must do is “Configure” the Decoder System.

**STEP #1:** “FRONT OFFICE” SCREEN HEADER

Start from the “Front Office” screen of the software.



CLICK ON THE “ITEM 2” ICON

The following screen, showing additional Icons on the Front Office Header, will now be displayed.

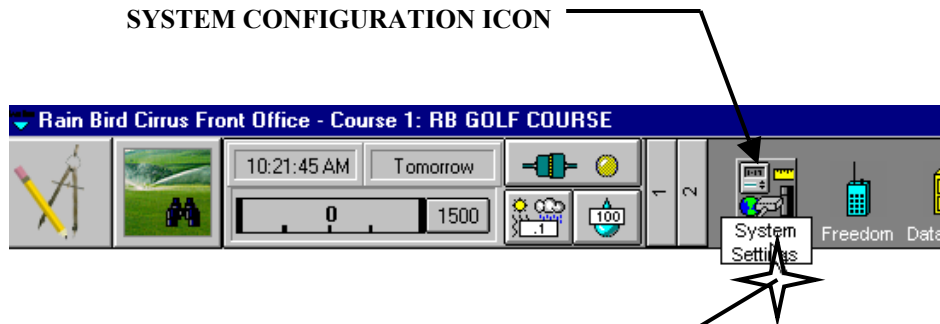

**CLICK ON THE "SYSTEM CONFIGURATION" ICON**

The following "System Settings" screen will be displayed . . .

**STEP #2:**

Since we are configuring a "Decoder" system – CLICK on the Decoder Cell.

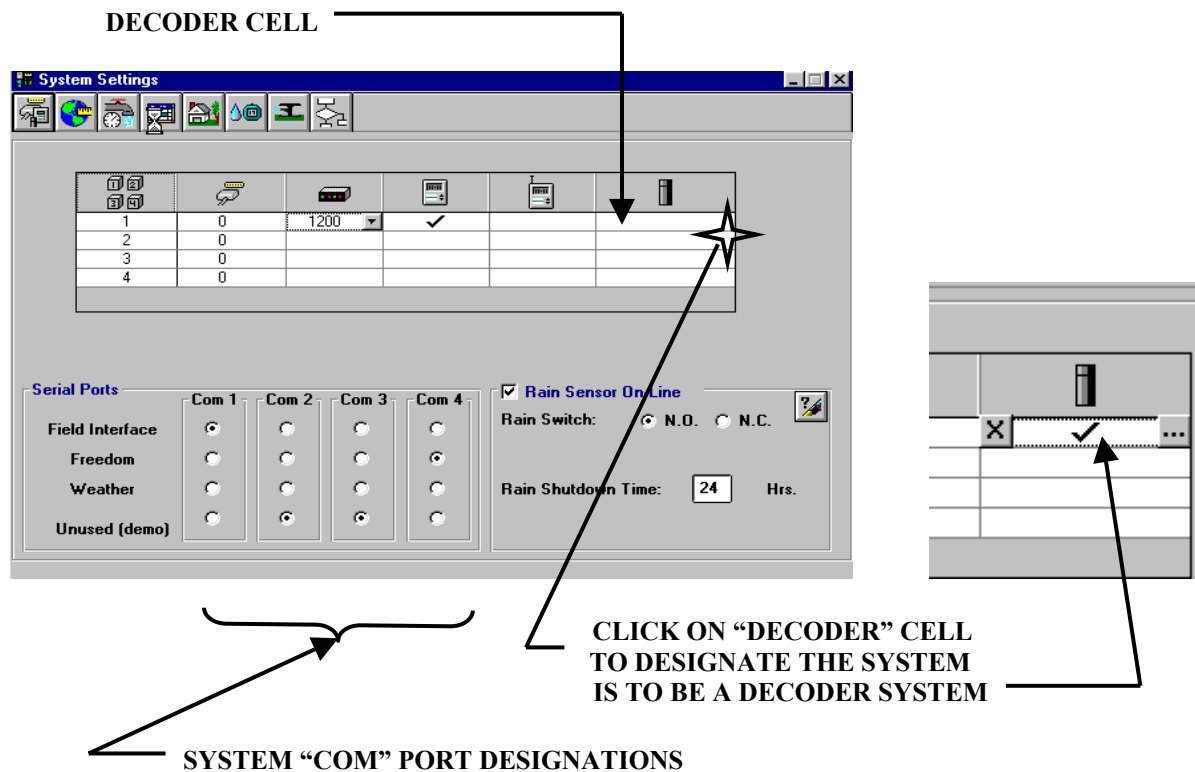

**STEP #3:**

Designate the use for each of the various COM Ports of your computer.

**STEP #4:**

Designate if you have a Rain Sensor on your system and whether its threshold condition is “Normally Open” (N.O.) or “Normally Closed” (N.C.). Indicate the duration of the Rain Shut-Down period desired. Also designate – if you have a Pump Alarm and/or a Line Voltage Alarm on your system.

Your “System Settings” screen should now appear similar to the screen displayed below . . .

**THIS DATA IS AUTOMATICALLY ENTERED WHEN YOU DESIGNATE THE SYSTEM TO BE A DECODER TYPE SYSTEM**

**SYSTEM DESIGNATED TO BE A DECODER SYSTEM**

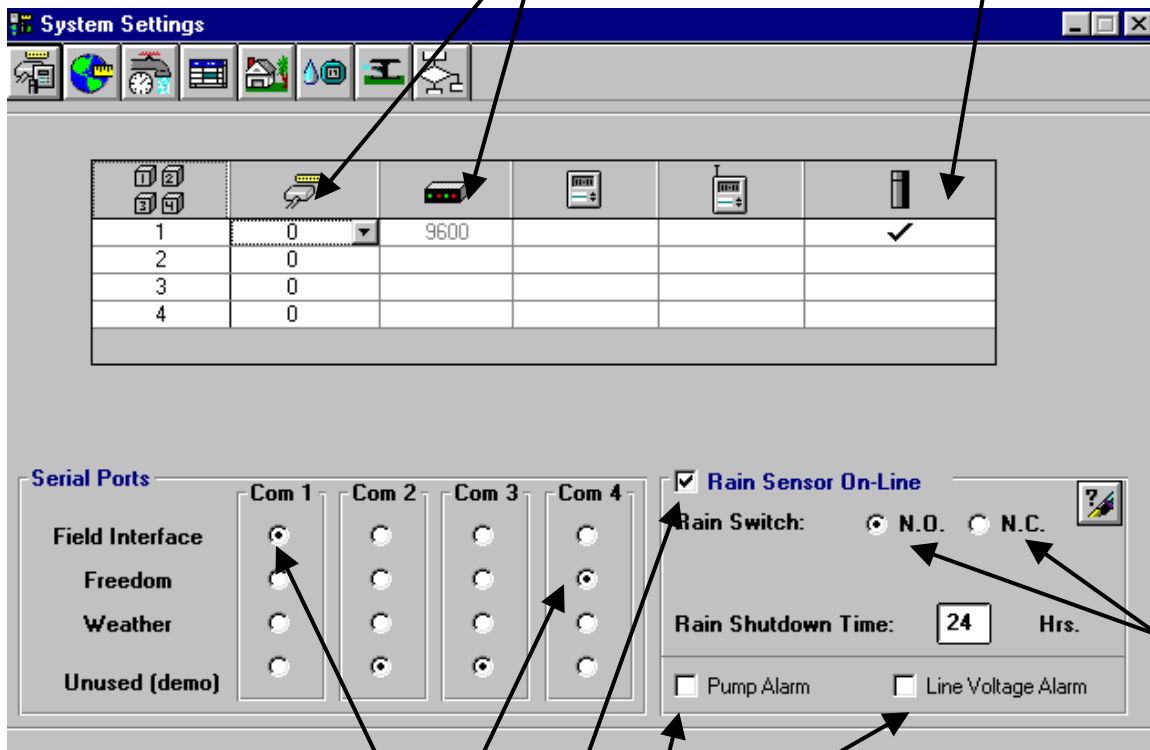

**“COM” PORT DESIGNATIONS**

**CLICK HERE IF YOU HAVE A PUMP ALARM OR A LINE VOLTAGE ALARM**

**CLICK HERE IF YOU HAVE A RAIN SENSOR ON YOUR SYSTEM & WANT IT “ON-LINE”**

**DESIGNATE IF THE SENSOR THRESHOLD CONDITION IS “NORMALLY OPEN” (N.O.) OR “NORMALLY CLOSED” (N.C.) BY “CLICKING”**

## Entering Decoder Data:

### STEP #1:

From the FRONT OFFICE screen – SELECT “Station Detail” as shown below . . .

CLICK ON “STATION DETAIL” ICON



The “Station Detail” screen, as shown below, will be displayed . . .

### STEP #2:

The screen automatically shows **Course Number 1** and **Hole Number 1** as being selected to program. If this is not the Course or the Hole you wish to program – then select the proper Course Number and Hole Number you want to program.

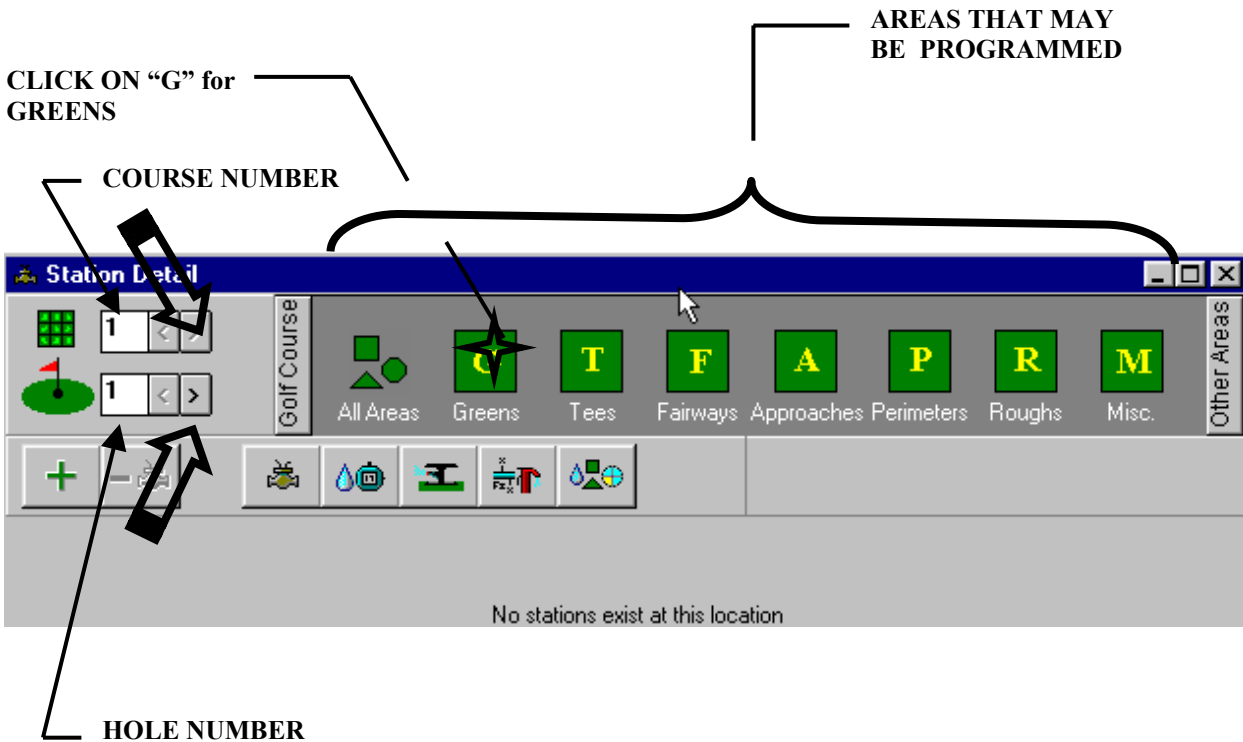

**STEP #3:**

Select the Area that you wish to program.

Having selected the proper Course Number and Hole Number – then **CLICK** on the **AREA** you wish to program – in this example we want to program the **GREENS**. Clicking on the GREENS Icon the following screen will be displayed . . .

Screen is displayed showing “1G1” as the first Decoder to be identified in this table.

**STEP #4:**

Enter the Decoder Identification Code Number for location “1G1”

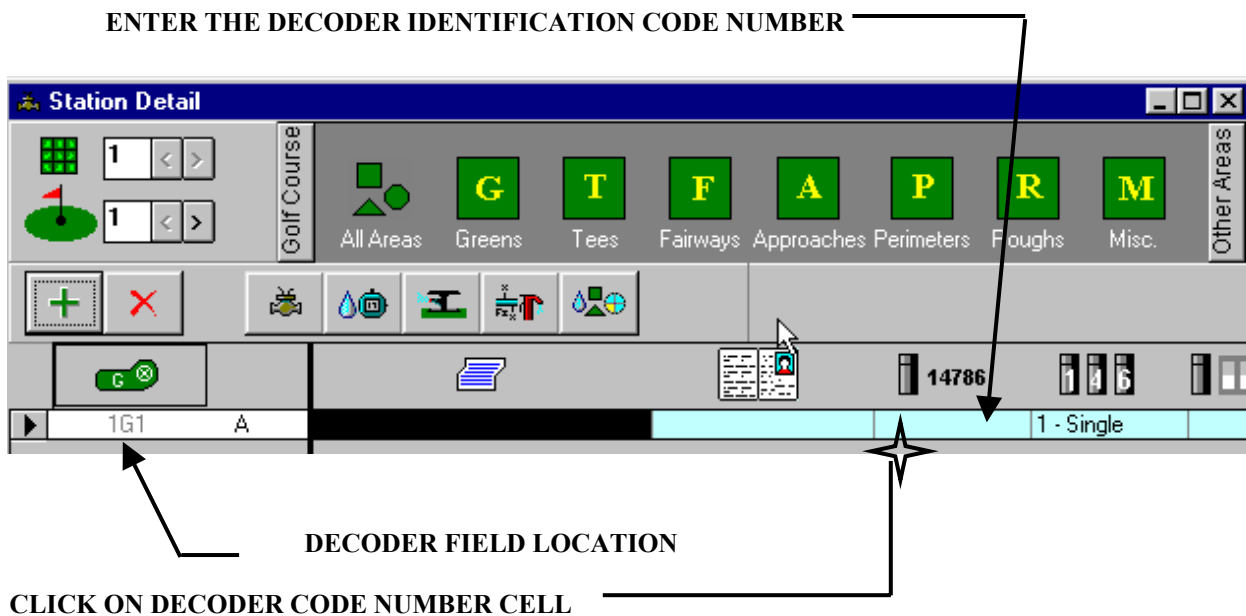

After **CLICKING** on the cell – **ENTER** the Decoder Code Number. In this example use Code Number **1150**.

The Code Number will be shown in the Decoder Identification Code Number CELL – as shown below...

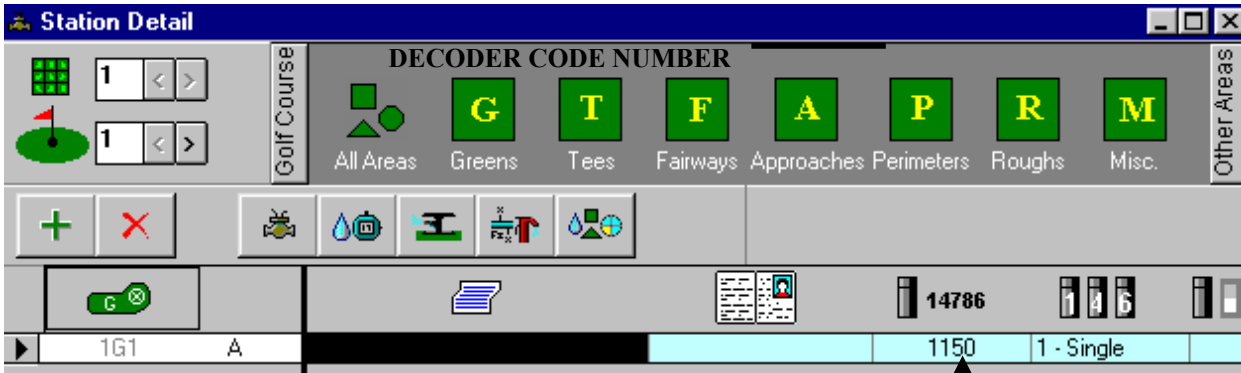

**STEP #5:**

**DECODER CODE NUMBER**

In addition to entering the Decoder Code Number – you also need to designate if the decoder is a single output (default status), four output or six output type decoder.

**DESIGNATE TYPE OF DECODER BY CLICKING ON CELL AND SELECTING PROPER TYPE**

**CLICK ON CELL AND THEN CLICK ON ARROW TO GET DROP-DOWN SCREEN**

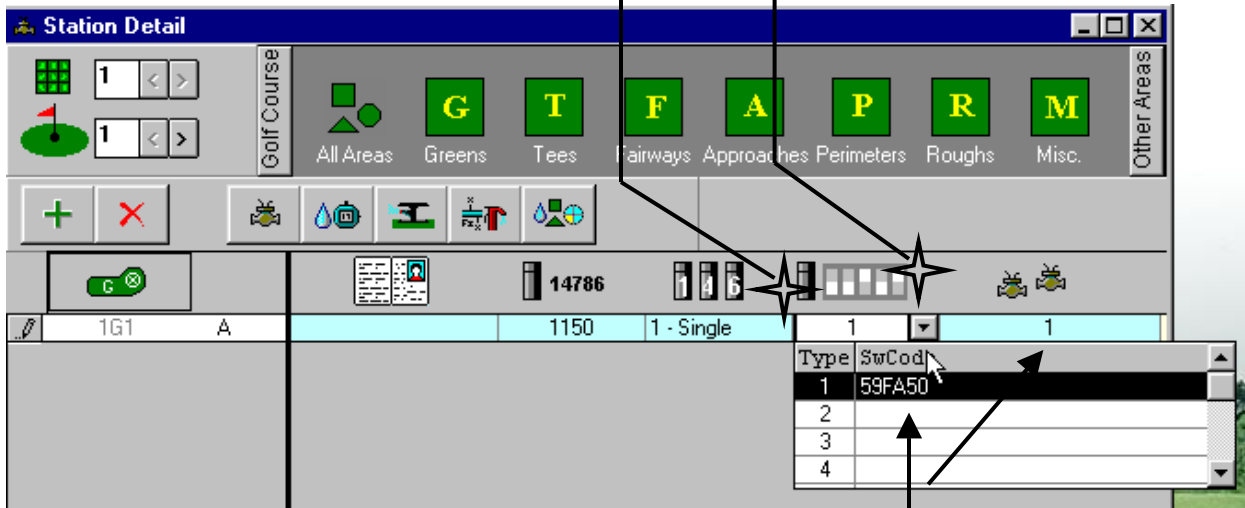

**STEP #6: NUMBER OF SOLENOIDS ON DECODER OUTPUT**

**ENTER NEW SWITCH CODE IF REQUIRED - CLICK ON CELL AND ENTER NEW CODE**

Default Switch Code (#1) is automatically entered. Enter a different Switch Code if required for type of solenoid you have.

**STEP #7:**

Default Number of solenoids, being operated by decoder output is ONE (1). Change if required.

The other data in this table will be automatically entered in accordance with the data you have entered for the various “System Data Tables”. Adjustments may be made on an individual station basis as may be required.

**STEP #8:**

Enter, in a similar manner, the data for each of the other decoders that you may have for this selected area (Green #1 – in this case).

To advance to the next station – CLICK on the PLUS (+) Icon.

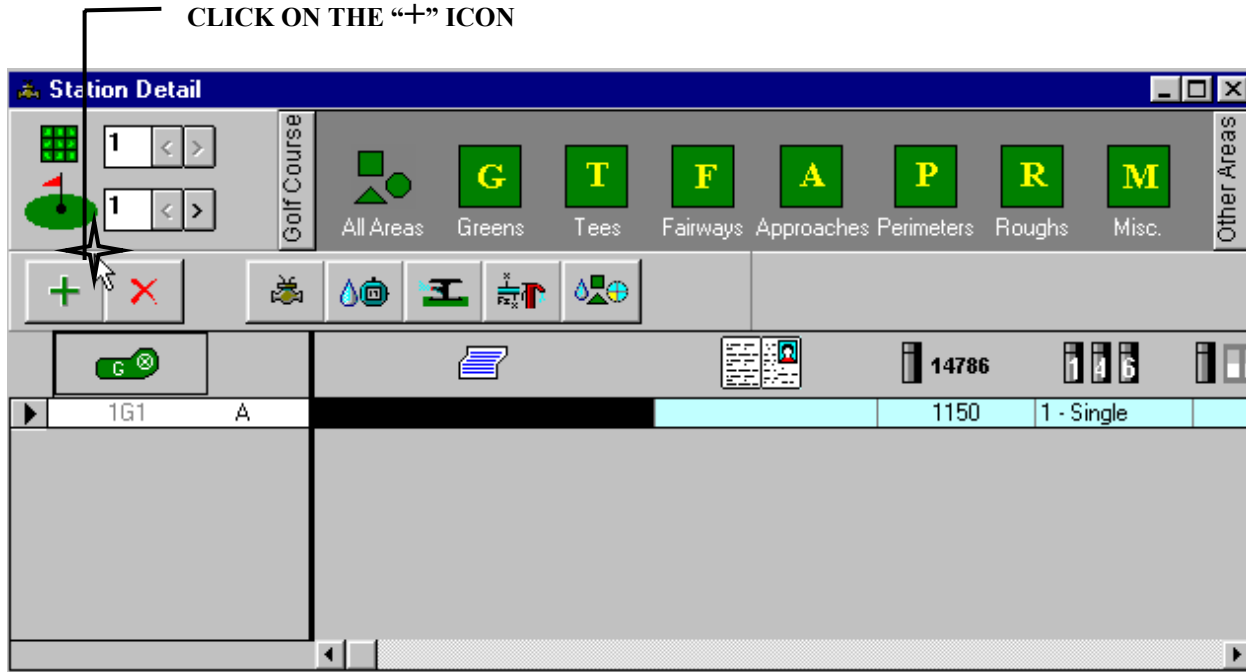

Station 1G2 will now be displayed – and you can enter the proper data for it. Repeat this for each of the other decoders that you have for this area.

When you have finished entering the data for all the decoders at this Green – your table should appear similar to the screen shown below . . .

**(REFER TO NEXT PAGE FOR SCREEN)**

**GREEN #1**

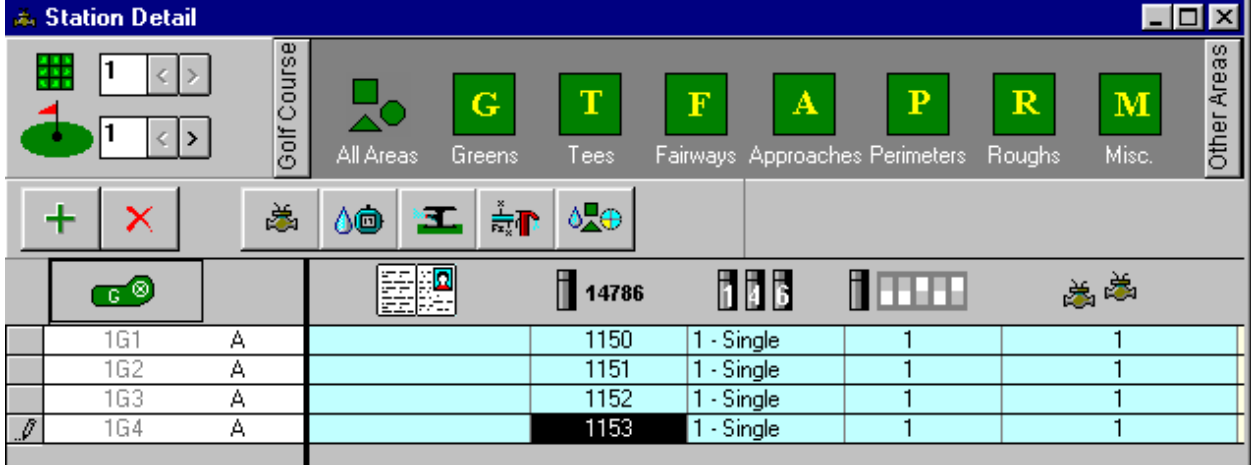

SCREEN SHOWS DECODER CODE NUMBERS AND DATA FOR ALL FOUR DECODERS AT GREEN #1

**Repeat Steps #1 through #8, as shown above, for entry of all Decoder data for all the other areas of your system.**

When you have finished entering all decoder data for each hole you should have screens similar to these shown below for each hole of your system.

**TEE #1**

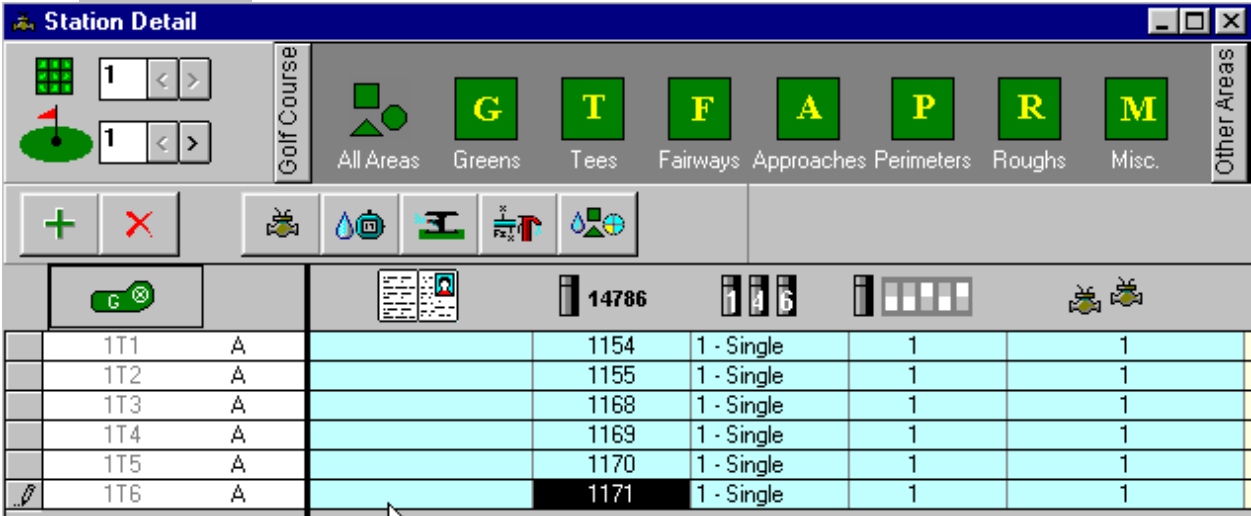

## OTHER SAMPLE SCREENS

### FAIRWAY #1

**Station Detail**

1 1

Golf Course

All Areas Greens Tees Fairways Approaches Perimeters Roughs Misc. Other Areas

+ X

14786

1F1	A	1172	1 - Single	1	1
1F2	A	1173	1 - Single	1	1
1F3	A	1174	1 - Single	1	1
1F4	A	1175	1 - Single	1	1
1F5	A	1176	1 - Single	1	1

### GREEN #4

**Station Detail**

1 4

Golf Course

All Areas Greens Tees Fairways Approaches Perimeters Roughs Misc. Other Areas

+ X

14786

4G1	A	1197	1 - Single	1	1
4G2	A	1210	1 - Single	1	1
4G3	A	1211	1 - Single	1	1

**TEE #4**

Station ID	Area Type	Value 1	Value 2	Value 3	Value 4	Value 5
4T1	A	1212	1 - Single	1	1	1
4T2	A	1213	1 - Single	1	1	1
4T3	A	1214	1 - Single	1	1	1
4T4	A	1215	1 - Single	1	1	1

**FAIRWAY #4**

Station ID	Area Type	Value 1	Value 2	Value 3	Value 4	Value 5
4F1	A	1216	1 - Single	1	1	1
4F2	A	1217	1 - Single	1	1	1
4F3	A	1218	1 - Single	1	1	1
4F4	A	1219	1 - Single	1	1	1
4F5	A	1220	1 - Single	1	1	1
4F6	A	1221	1 - Single	1	1	1

**OTHER SCREENS FOR YOUR SYSTEM WOULD BE SIMILAR. YOUR SYSTEM SHOULD NOW BE PROGRAMMED FOR OPERATION AS A DECODER TYPE SYSTEM.**

## Decoder “Switch Code”:

The Decoder “Switch Code” is necessary to assure that the proper Electrical Characteristics (current, voltage and time) are delivered to the Decoder for operation of the Valve-in-Head or Remote control valve solenoid.

Magnetic Solenoids on Valve-in-Head rotors or on remote control valves operate with a complex voltage in order to save energy. The voltage varies with the time as shown in the **FIGURE 6.1** below.

In the beginning the voltage must be “**HIGH**” (**Va**) in order to make the mechanical parts move. When the valve has opened or the relay has activated (in the case of a pump decoder), it is normally possible to **lower the voltage (Vh)** and still keep the solenoid or relay in the activated condition.

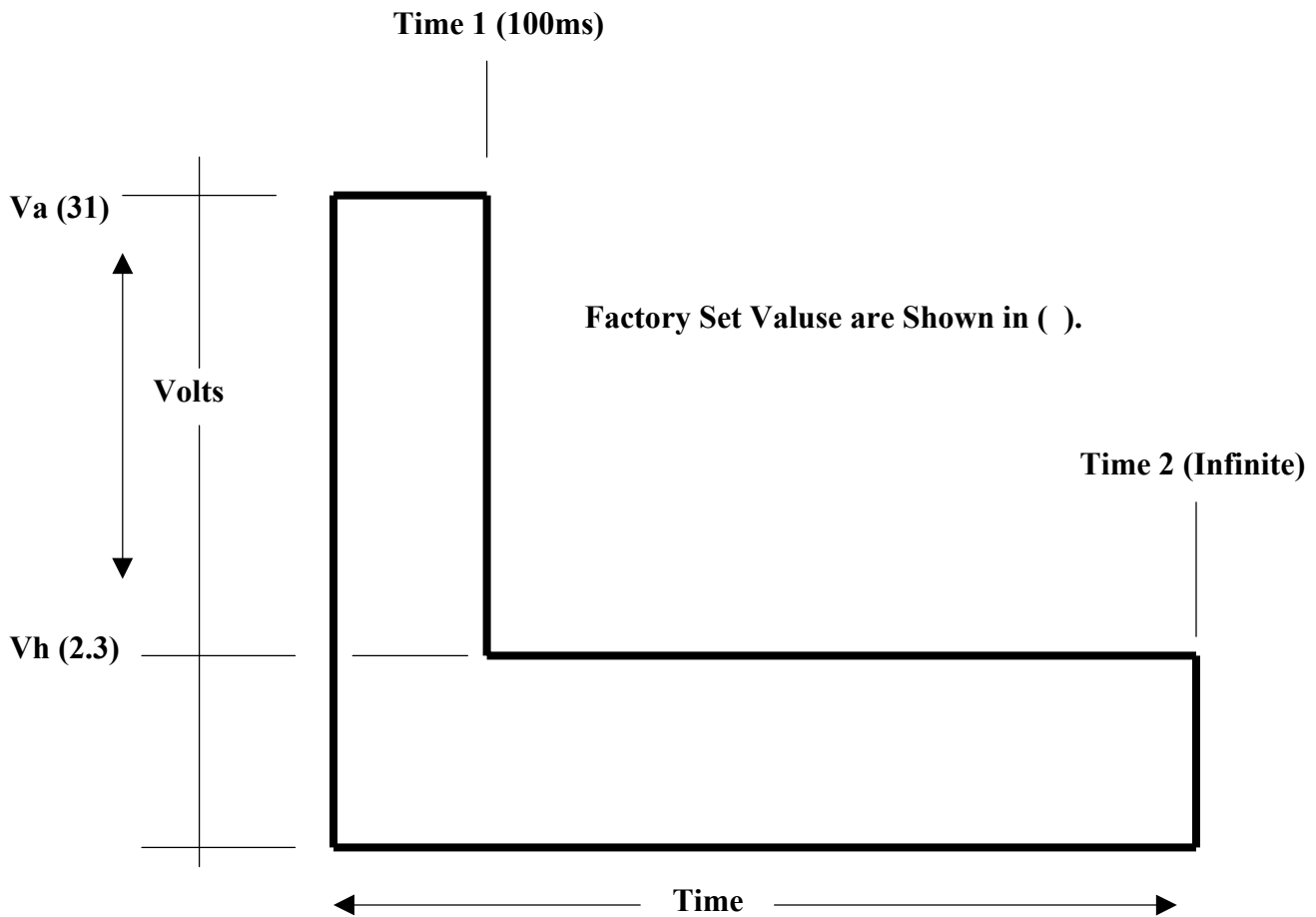

**Activating Voltage for Solenoid or Relay**  
**FIGURE: 6.1**

# Standard “Switch Code” for Rain Bird Solenoids: (Standard = 59FA50)

The Rain Bird Solenoid uses a Standard “Switch Code” of **59FA50**. This assures that the “Initial” voltage of **31 volts** is present for the proper amount of time of **100ms** – to make sure the solenoid activates properly and secondly to facilitate the proper “feed back” from the decoder back to the central computer.

The “Switch Code” for each Decoder can be entered in either one of TWO places in the software.

## AREA #1:

The “Switch Code” can be entered on the “Station Detail” tables as you enter the Decoder Identification Code Number.

From the software “Front Office” tool bar – **CLICK** on the “Station Detail” ICON.



The “Station Detail” screen will now be displayed as shown below.

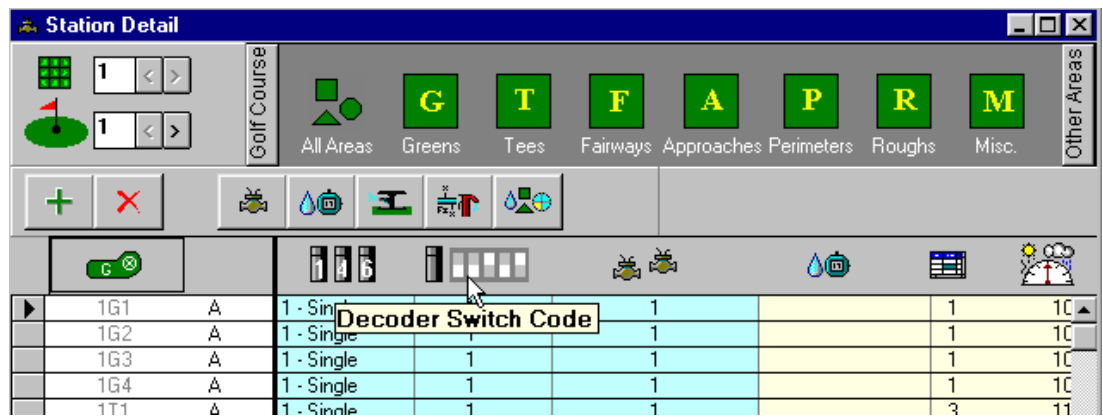

It will be noted in the “Station Detail” screen above that the Decoder “Switch Code”, for each decoder is automatically entered as “1”, which is for the STANDARD Swith Code of 59FA50. This can be seen from the screen that is displayed below

**2<sup>nd</sup> CLICK ON THE “ARROW” TO GET THE “DROP-DOWN” SCREEN**

**1<sup>st</sup> CLICK ON THE CELL FOR DECODER SWITCH CODE**

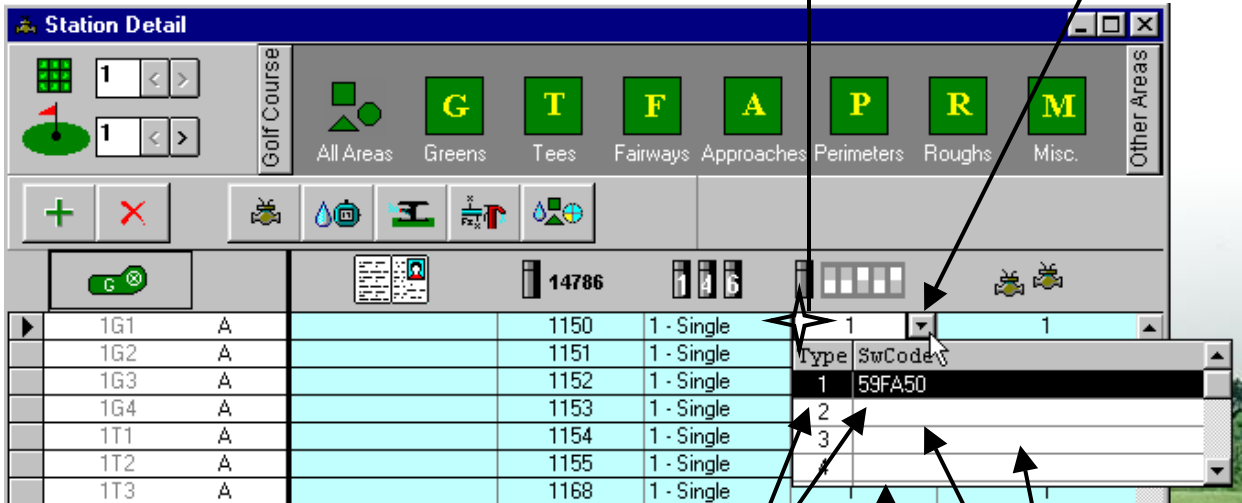

**TYPE “1” IS THE STANDARD SWITCH CODE**

**”DROP-DOWN” SCREEN**

**OTHER “SWITCH CODES” MAY BE ENTERED IN THESE CELLS**

Other “Switch Codes” that may be required, can be entered at this – the “Station Detail” screen - as you enter the Decoder Identification Code Number and other data for it.

**AREA #2:**

The Decoder “Switch Code” can also be entered at the “System Configuration” Screen as you set up your system for Decoder operation. From the “Front Office” Tool Bar – **Click on Item 2.**



This will give you the second part of the Front Office Tool Bar – as shown below.

“SYSTEM SETTINGS” ICON



CLICK ON THE “SYSTEM SETTINGS” ICON

CLICK on the “System Settings” ICON and the screen will be displayed as shown below.

CLICK ON THE “DECODER” CELL

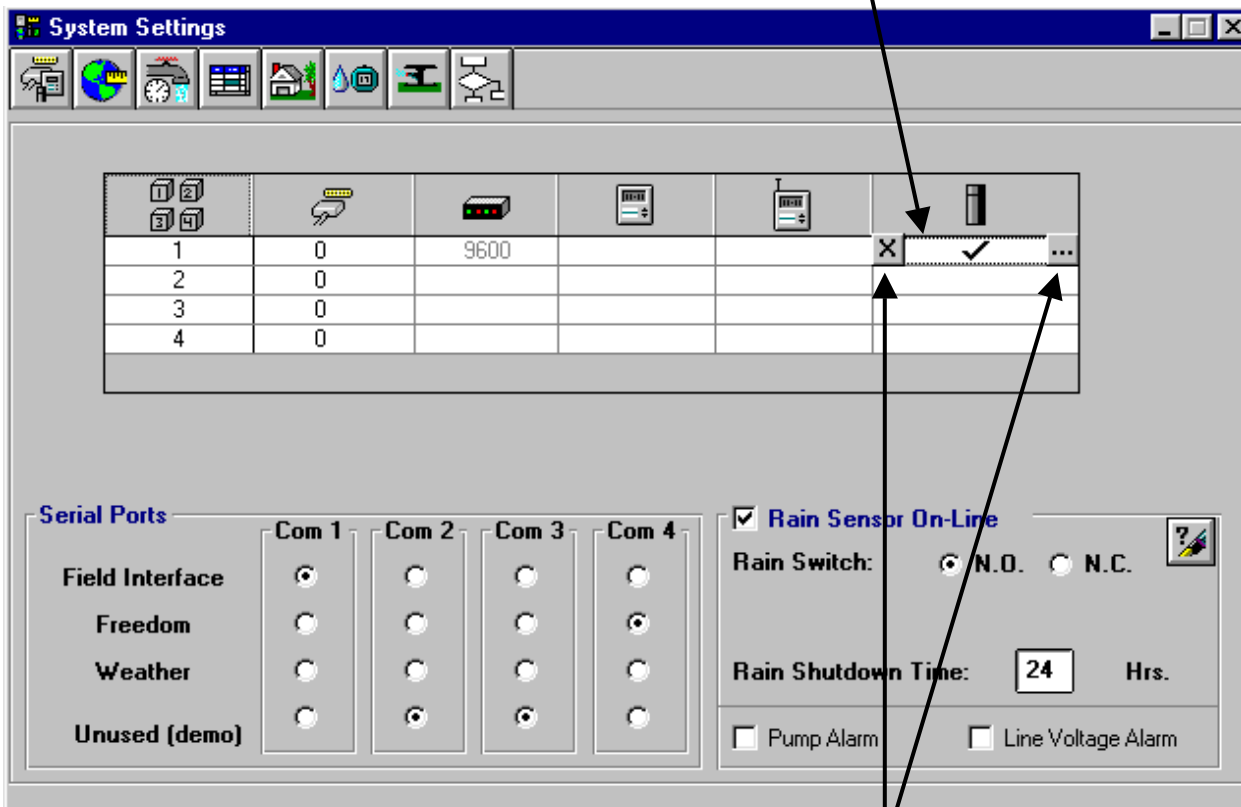
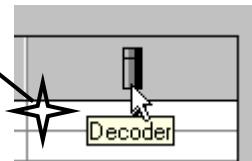

THIS WILL DISPLAY THE TWO SMALL ICONS AS SHOWN

CLICK on the Right small ICON

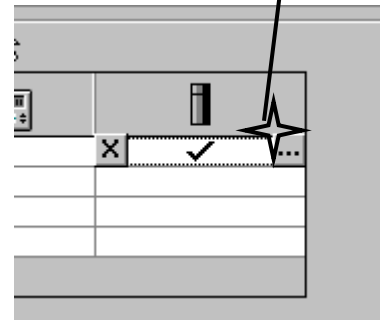

This will display the “drop-down” screen as shown below.

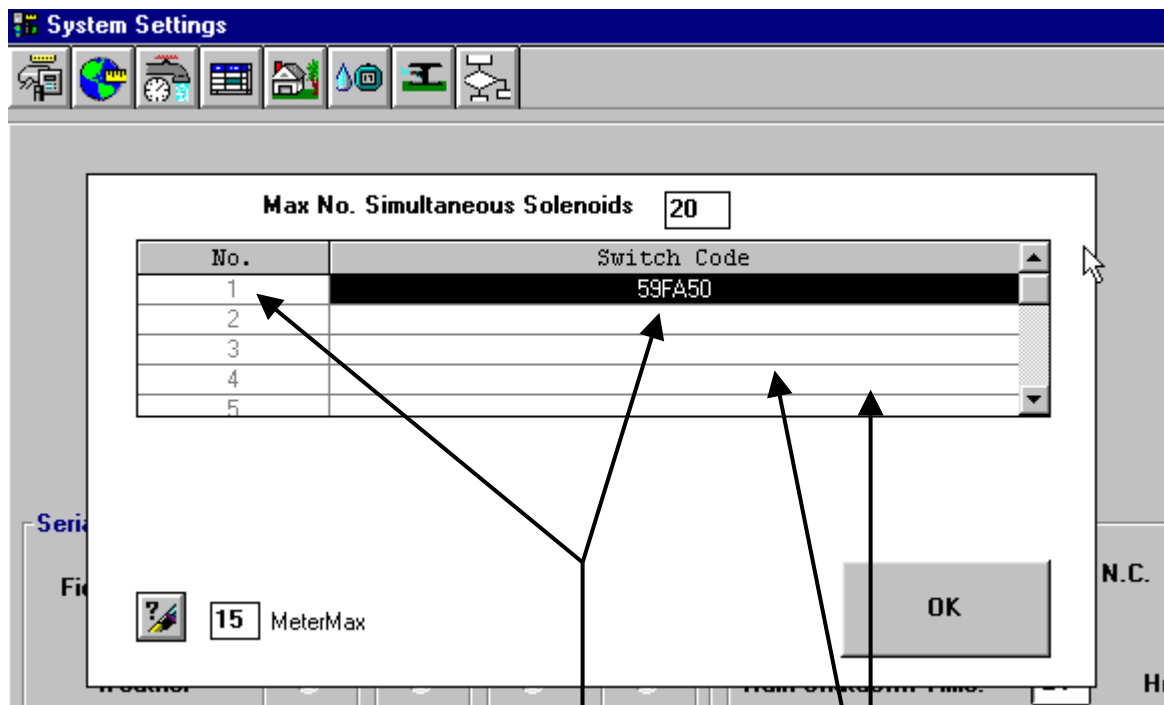

TYPE 1 IS SHOWN AS THE STANDARD  
“SWITCH CODE” OF 59FA50

OTHER “SWITCH CODES” THAT MAY BE REQUIRED  
CAN BE ENTERED INTO THESE CELLS

Assume we need to enter a different  
special “Switch Code” of 59FC80.  
CLICK on the Type 2 cell and enter  
the special “Switch Code” as shown .

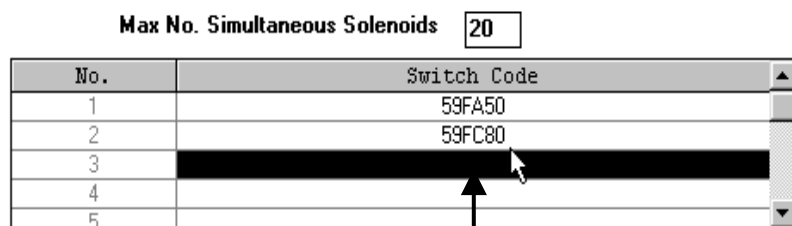

NEW “SWITCH CODE” FOR TYPE 2 HAS BEEN ENTERED

If you check back to the “Station Detail” screen you will see that this TYPE 2 special “Switch Code” has been automatically entered at this screen also.

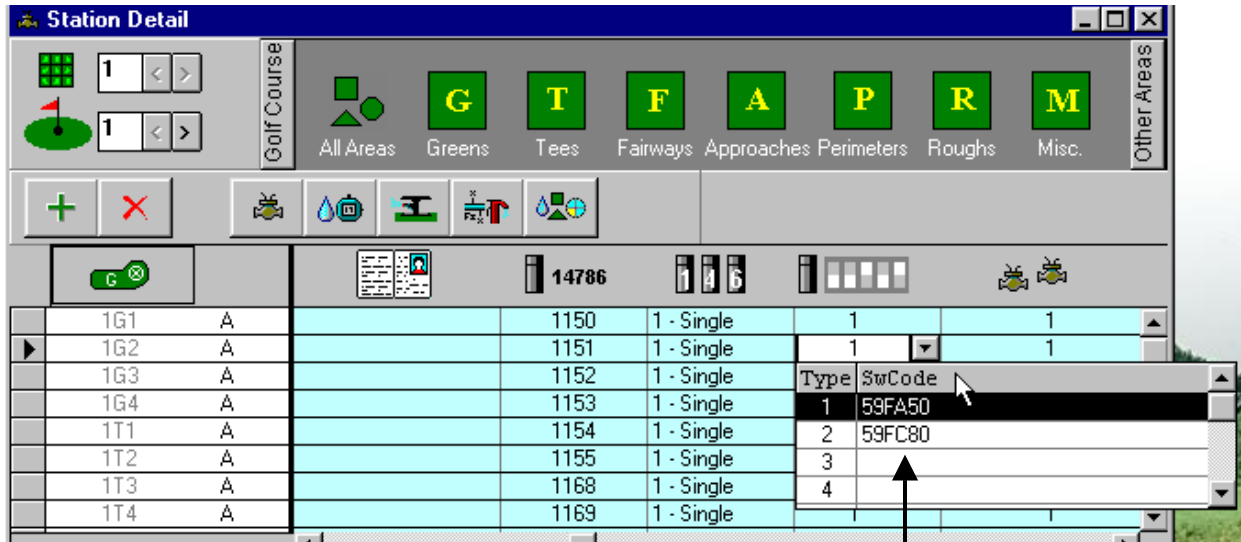

SPECIAL “SWITCH CODE” FOR TYPE 2  
HAS BEEN AUTOMATICALLY ENTERED  
HERE

## Asjusting the Electrical Requirement Decoder “SWITCHING CODE” for Varying Types of Solenoids:

When the valve or relay **DOES NOT** work with the Standard “Switching Code” (59FA50) – there are two properties that you may need to vary.

**If the Solenoid Does Not Open (Activate) at all:**

If the solenoid will **NOT open**, the activation time (**TIME 1**) should be prolonged because the activation voltage (**Va**) is already set to the **MAXIMUM (Va = 31 – set at the factory)**. Therefore, change the **FOURTH (4<sup>th</sup>) DIGIT** of the code according to **FIGURE 6.2** – which is shown below.

**Electrical Required CODE of Magnetic Solenoid**

5	9	F	0
<b>Time ms</b>	*	*	<b>Vh/Volt</b>
30	3	3	1.2
40	4	4	1.7
50	5	5	2.3
60	6	6	2.9
70	7	7	3.5
80	8	8	4.0
90	9	9	4.6
100	A	A	5.2
110	B	B	5.8
120	C	C	6.3
130	D	D	6.9
140	E	E	7.5
150	F	F	8.1

**TABLE for SELECTING SUITABLE ELECTRICAL CODE for SPECIAL SOLENOID (VALVE) TYPE.**

**FIGURE: 6.2**

**NOTE !** You will have to use the trial and error method until you get a value that works the solenoid satisfactorily.

**Example:** Activation Time = 110 ms

Holding Voltage = 2.3 volts

CODE to try = 4<sup>th</sup> Digit = B for 110 milli-seconds

∴ CODE = **59FB50**

This increases the “**Activation Time**” from the standard **100ms** to **110ms**. You can try this code and if it still does not operate satisfactorily then make further adjustments to the “**Activation Time**” until you get satisfactory operation.

## **If the Solenoid Opens (Activates) but does NOT Stay Open:**

If the solenoid activates but will not stay activated or “ON” (Valve closes back down), the **holding voltage (Vh)** is too low and should be increased. Change the **FIFTH (5<sup>th</sup>) DIGIT** of the Code according to **FIGURE: 6.2** shown above.

**NOTE !** Again you will have to use the trial and error method until you get a value that works the solenoid satisfactorily.

**Example:**      Activation Time = **100 ms**  
                    Holding Voltage = **4.0 volts**  
                    **CODE** to try = **5<sup>th</sup> Digit = 8** for 4.0 volts

**∴ CODE = 59FA80**

This increases the “**Holding Voltage**” from the standard **2.3** volts to **4.0** volts. You can try this code and if it still does not operate satisfactorily then make further adjustments to the “Holding Voltage” until you get satisfactory operation.

You can have as many different “**TYPES**” or special “**Switch Codes**” as you may require for your system. Each special Code that you need can be entered into the software as previously described above.

## **Setting Up “Pump Decoder” (Model PD-210) Operation in the System Software:**

*For this Example we will use FOUR (4) Pumps and thus use FOUR (4) PUMP DECODERS for Control of the Pumps for the system.*

**NOTE !** A Decoder System may have a **MAXIMUM** of **SIX (6)** Model PD-210 Pump Decoders (Pumps).

PD-210 DECODER FACE

The Model **PD-210** Pump Decoder has a **DIAL** on the face of it, which is used to set the Decoder Address Code Number for it. Refer to the Decoder Face shown in **FIGURE: 6.3** at the right

ADDRESS CODE SETTING DIAL

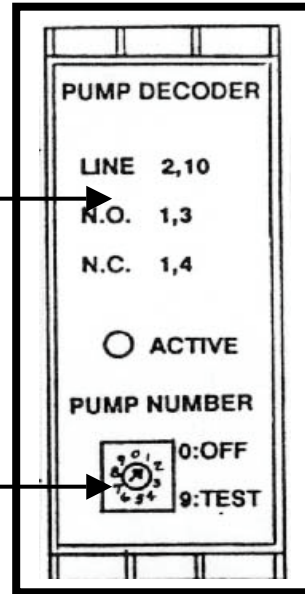

**PUMP DECODER FACE**  
**FIGURE: 6.3**

The Numbers on the DIAL automatically give the Address Code Numbers as follows:

- |                 |                 |
|-----------------|-----------------|
| #0 = OFF        | #9 = TEST       |
| #1 = <b>284</b> | #2 = <b>286</b> |
| #3 = <b>287</b> | #4 = <b>292</b> |
| #5 = <b>293</b> | #6 = <b>295</b> |

**Pump Station Data (for our example:)**

**Pump #1 = 150 GPM**

Pump Decoder Dial set at **#1**, which automatically sets the Address Code Number of **284**.

**Pump #2 = 350 GPM**

Pump Decoder Dial set at **#2**, which automatically sets the Address Code Number of **286**.

**Pump #3 = 500 GPM**

Pump Decoder Dial set at **#3**, which automatically Sets the Address Code Number of **287**.

**Pump #4 = 500 GPM**

Pump Decoder Dial set at **#4**, which automatically sets the Address Code Number of **292**.

**TOTAL PUMP STATION CAPACITY = 1500 GPM**

# Entering Decoder System Pumping Station Data into the System Software:

Starting from the Front Office Tool Bar (Section 3) – CLICK on the “Flo Manager” ICON, as shown below.

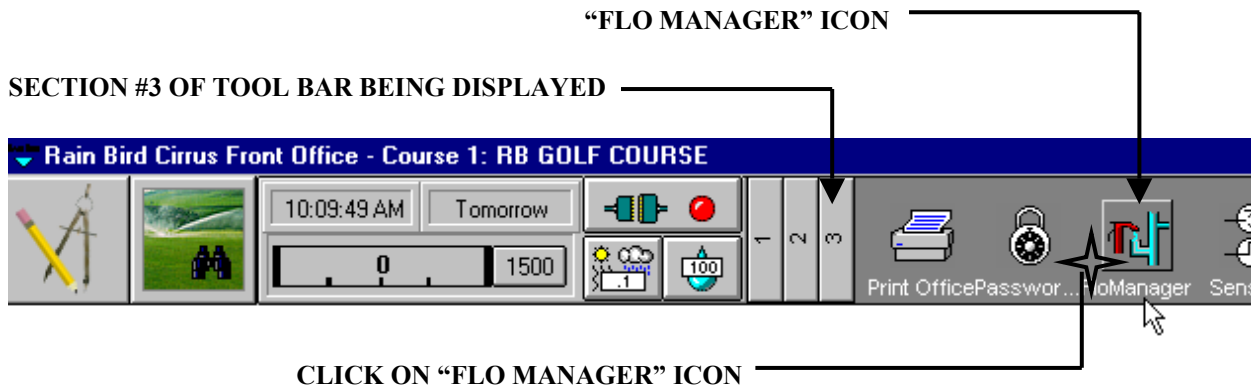

The “Flo Manager” screen will now be displayed as shown at the right.

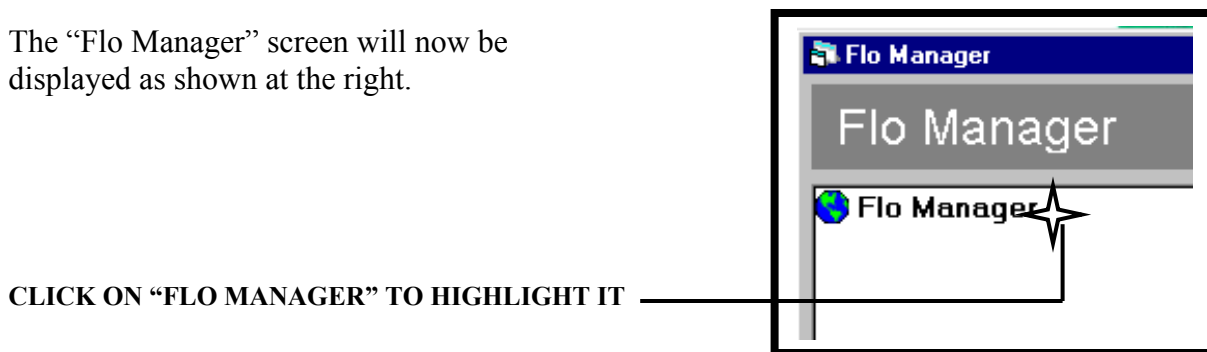

With “Flo Manager” now highlighted – CLICK the “RIGHT” mouse button to have the “drop-down” screen displayed.

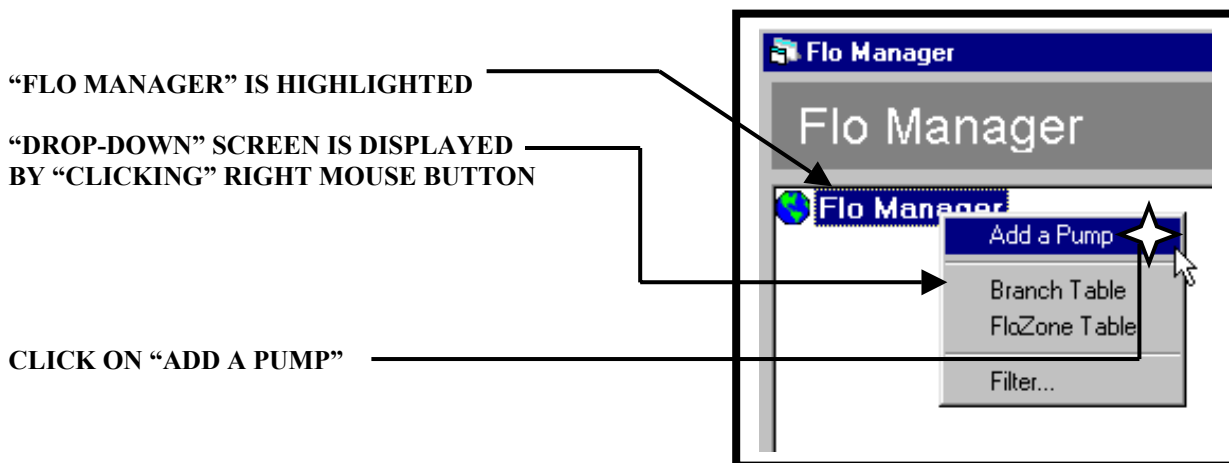

Upon clicking on “Add a Pump” the “PUMP PROPERTIES” screen will be displayed , as shown below.

**ENTER A NAME IF YOU WISH  
CLICKING ON THE CELL AND  
ENTERING THE NAME**

**ENTER THE TOTAL CAPACITY OF THE SYSTEM**

Level	Capacity	Delay	1	2	3	4	5	6	7	8	9	10	11	12	13	14	15	16	17	18	19	20	21	22	23	24
1	1500		⊙	⊙	⊙	⊙															⊙	⊙	⊙	⊙	⊙	⊙
2																										
3																										
4																										
5																										
6																										
7																										
8																										
9																										
10																										
11																										
12																										
13																										
14																										
15																										

**AFTER CLICKING ON “APPLY”  
THEN CLICK ON “OK”**

**WHEN ALL DATA IS CORRECT  
THEN CLICK ON “APPLY”**

**DESIGNATE THE HOURS OF THE DAY THAT YOU WILL  
ALLOW FULL PUMPING STATION CAPACITY – BY  
“CLICKING” ON THE DESIRED HOUR CELL**

Enter the following data in the chart:

Pump Name (if desired)

Total System Capacity (GPM)

Hours of the Day that you will allow full system capacity to flow

Then Click on “Apply” and followed by clicking on “OK” to permanently enter data.

Pump Data will now have been entered into the “Flo Manager” screen, as shown at the right.

**PUMP “P1” AT 1500 GPM HAS BEEN ENTERED INTO THE “FLO MANAGER” SCREEN**

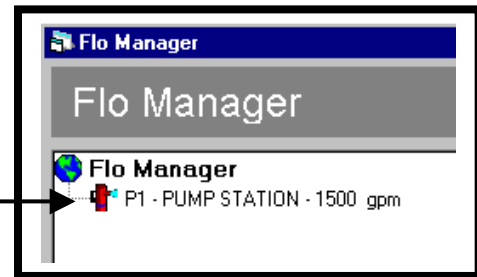

If you check the “FRONT OFFICE” TOOL BAR – you see that the TOTAL system Capacity is also displayed here.

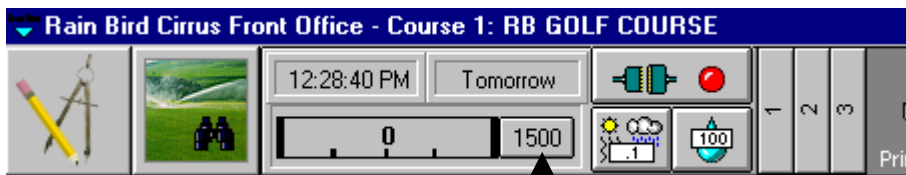

**TOTAL SYSTEM CAPACITY (GPM) IS AUTOMATICALLY DISPLAYED HERE**

## Entering Individual Pump Data, for System Pumping Station, into the System Software:

Starting from the “FRONT OFFICE” TOOL BAR (Section 2) – CLICK on the “System Settings” ICON, as shown below.

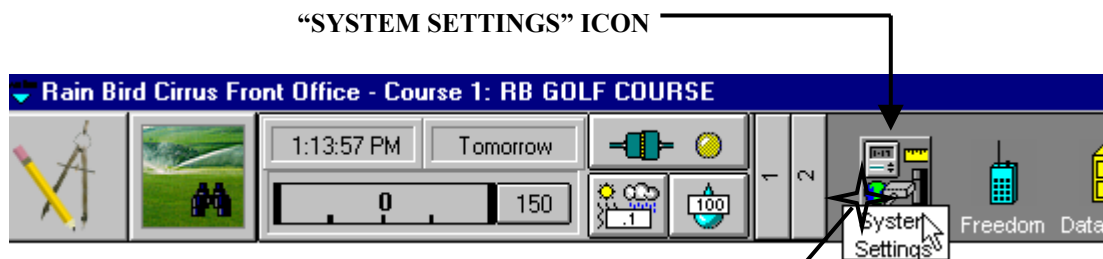

**CLICK ON THE “SYSTEM SETTINGS” ICON**

The “System Settings” screen will then be displayed as shown below. **CLICK** on the “System Capacities” ICON as shown.

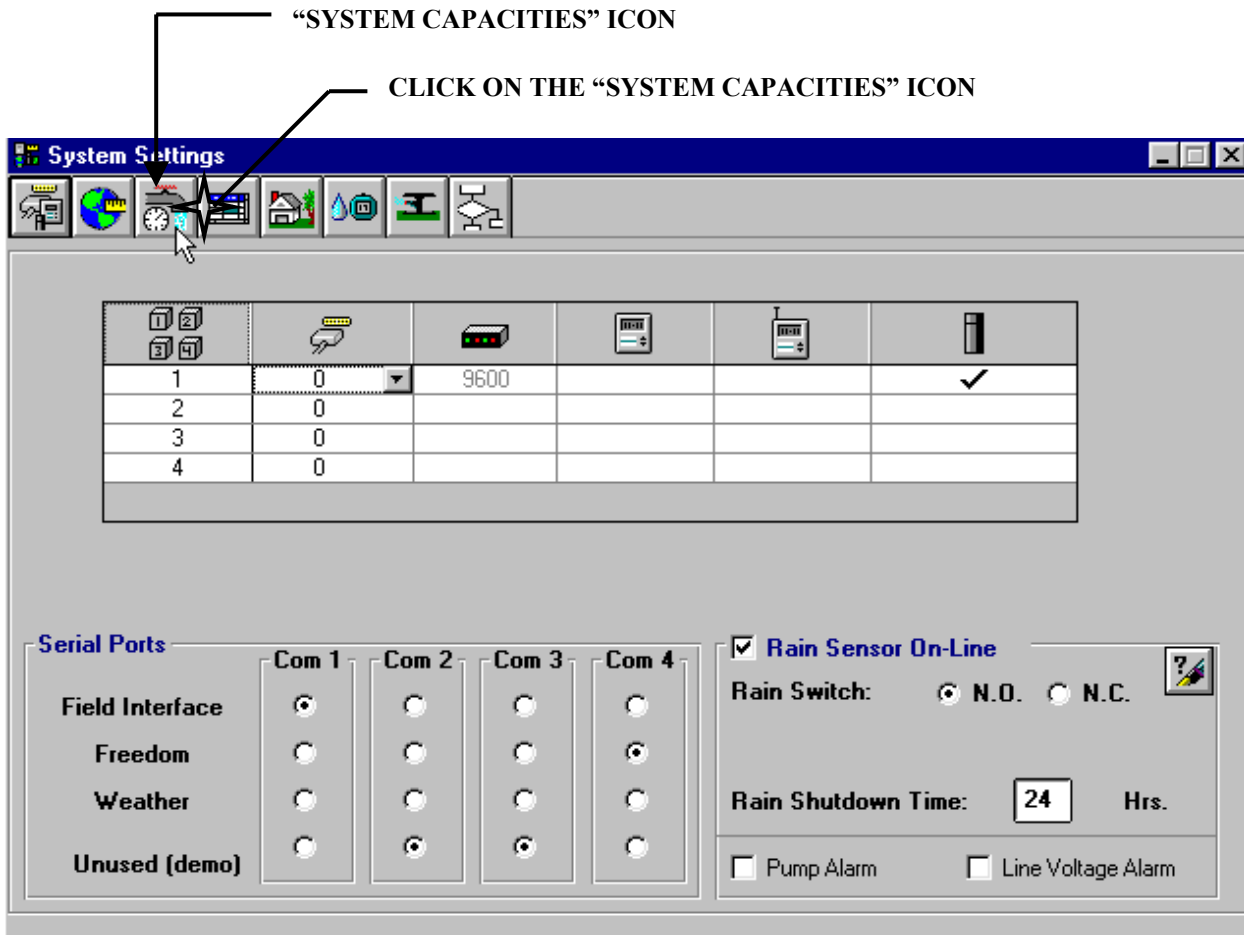

Upon CLICKING on the “System Capacities” ICON the following screen will then be displayed.

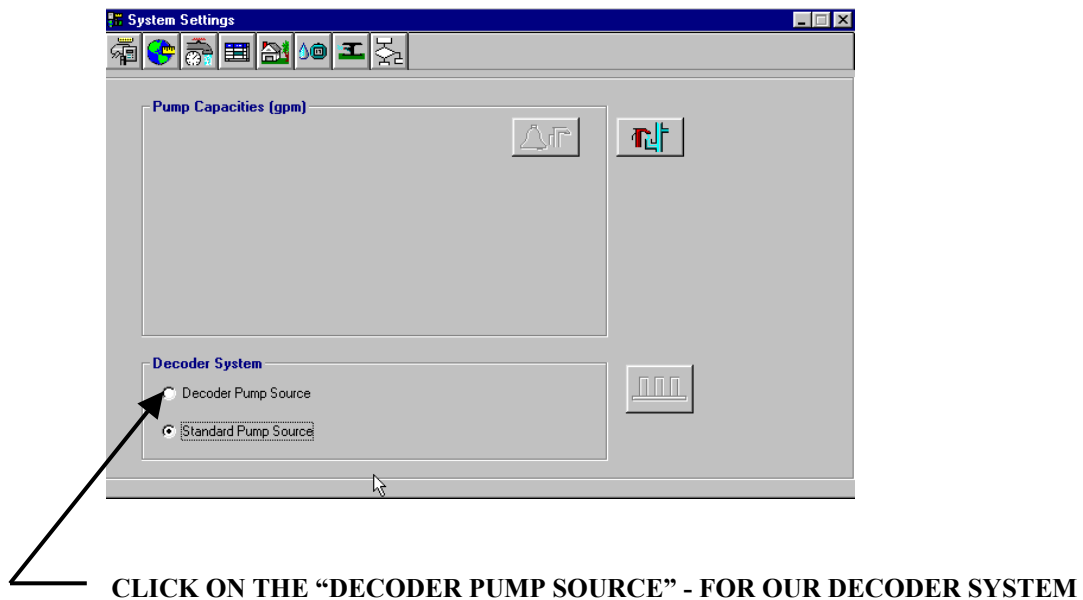

The screen will now be displayed as shown below.

**CLICK ON THE DECODER PUMPS  
PUMPS ICON – TO SET UP  
PUMP DECODER DATA**

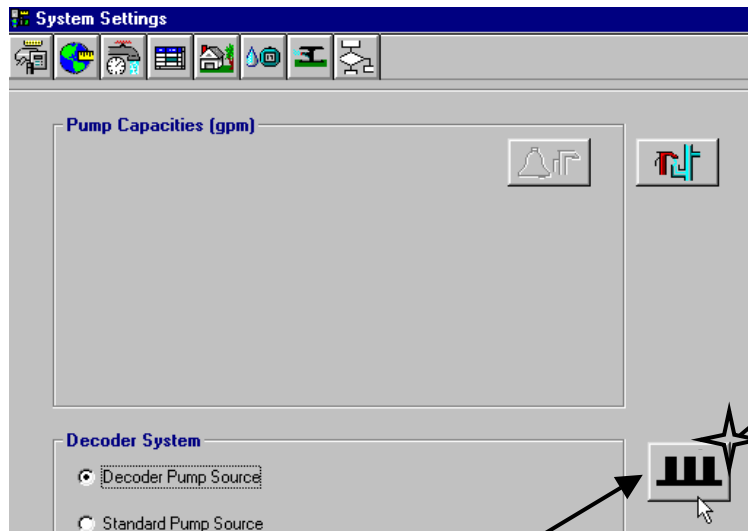

**DECODER PUMPS ICON  
IS NOW DISPLAYED**

Upon CLICKING on the “Decoder Pumps” ICON – the following screen will now be displayed.

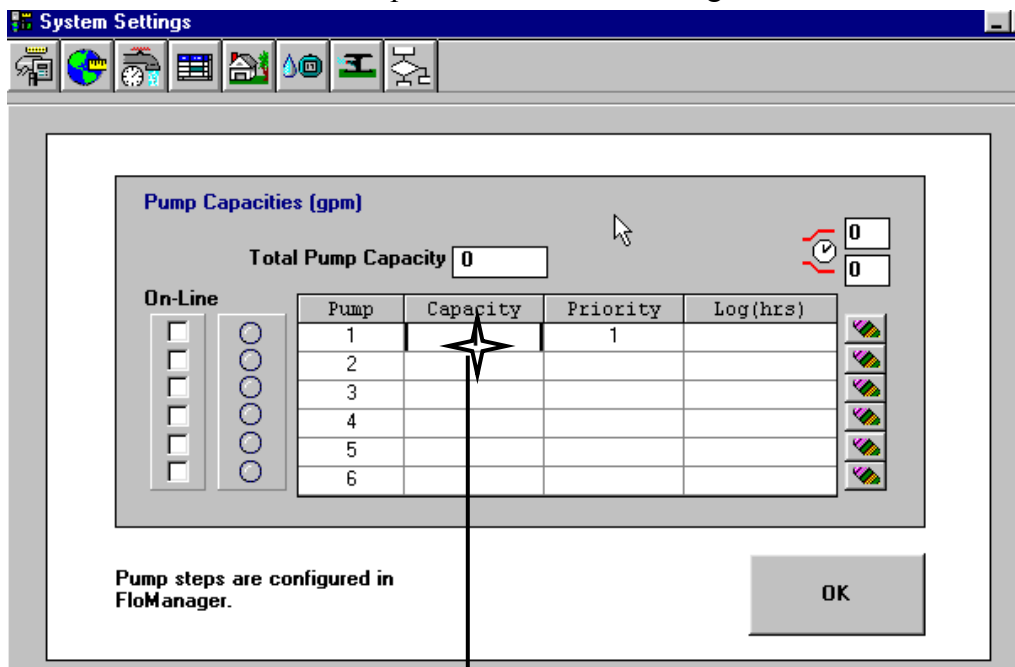

**CLICK ON THE “CAPACITY” CELL  
FOR PUMP #1 AND ENTER THE  
PUMP CAPACITY**

TOTAL CAPACITY IS REFLECTED HERE

CLICK on the “Capacity” Cell for Pump #1 and enter the Pump Capacity – in our example it is 150 GPM

**Pump Capacities (gpm)**

Total Pump Capacity **150**

On-Line

Pump	Capacity	Priority	Log(hrs)
1	150	1	

CLICK ON “CAPACITY” CELL AND ENTER GPM

SYSTEM CAPACITY AUTOMATICALLY UPDATES AND NEW PUMP IS ADDED

CLICK on the “Capacity” Cell for Pump #2 and enter the Pump Capacity - in our example it is 350 GPM

**Pump Capacities (gpm)**

Total Pump Capacity **500**

On-Line

Pump	Capacity	Priority	Log
1	150	1	
2	350	2	
3			
4			

CLICK ON “CAPACITY” CELL AND ENTER GPM

AS EACH PUMP IS ADDED THE TOTAL SYSTEM CAPACITY IS UPDATED

Next CLICK on the “Capacity” Cell for Pump #3 and enter the Pump Capacity – in our example it is 500 GPM

**Pump Capacities (gpm)**

Total Pump Capacity **1500**

On-Line

Pump	Capacity	Priority	Log(hrs)
1	150	1	
2	350	2	
3	500	3	
4	500	4	
5			

Repeat this procedure for Pump #4 – entering the capacity for it, which is 500 GPM

Our **PUMP TABLE** would now look as displayed below.

PRE & POST PRESSURIZING TIMES CAN BE ENTERED HERE

OPERATING TIME FOR EACH PUMP WILL BE LOGGED HERE

TOTAL SYSTEM CAPACITY IS DISPLAYED HERE

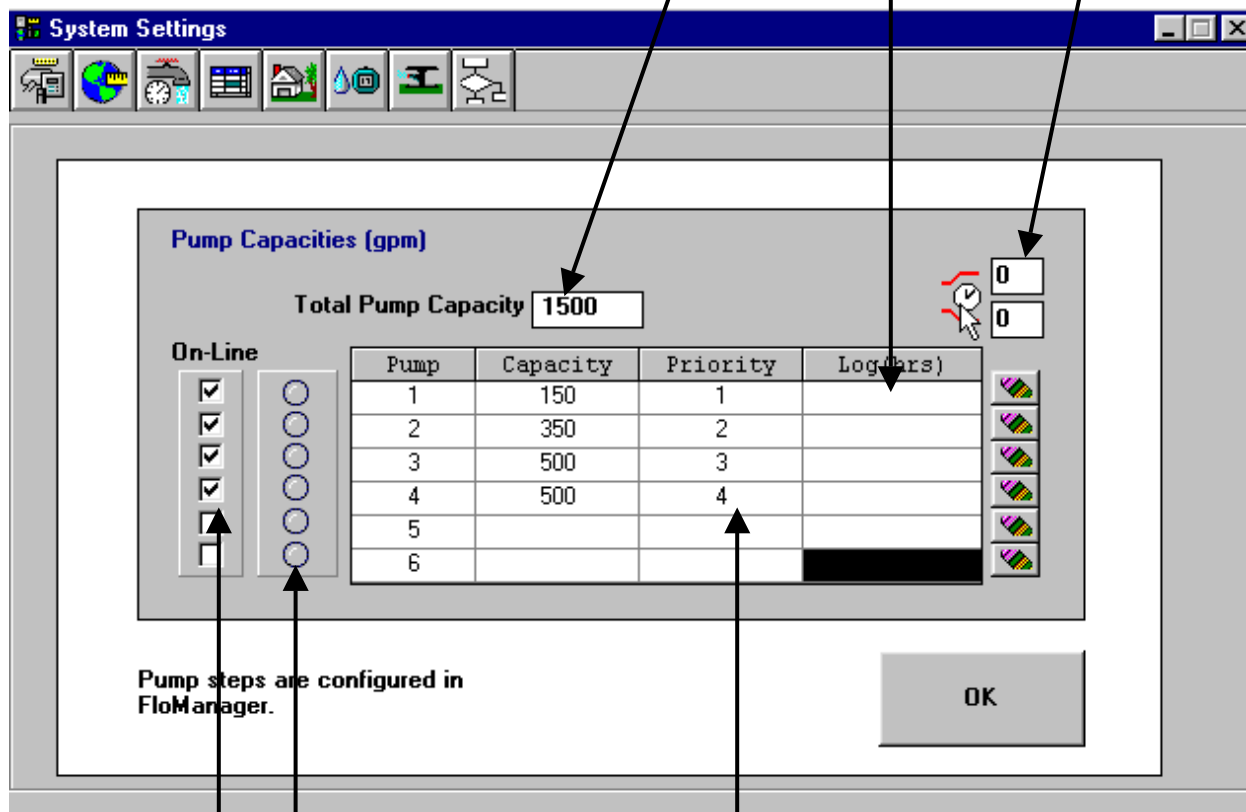

Pump steps are configured in FloManager.

LIGHT WILL INDICATE WHEN PUMP IS IN OPERATION

PRIORITY INDICATES THE ORDER IN WHICH EACH PUMP WILL BE TURNED "ON"

EACH PUMP MAY BE TAKEN "OFF" LINE OR PLACED "ON" LINE BY CLICKING ON THE "BOX" FOR PUMP DESIRED

### PRE - PRESSURIZING TIME:

The PRE & POST PRESSURIZING TIMES are in **SECONDS**. The "PRE PRESSURIZING TIME" is the designated time, from the time the pump "STARTS" until any thing on the system is actually **turned "ON"**. This allows time for the pump and the piping system to get up to pressure before any irrigation or additional irrigation is allowed to take place.

## POST - PRESSURIZING TIME:

The PRE & POST PRESSURIZING TIMES are in **SECONDS**. The “**POST PRESSURIZING TIME**” is the designated time, from the time the irrigation is **turned “OFF”** until the pump is actually **turned “OFF”**. This allows time for the piping system flow to gradually be reduced, preventing water hammer in the system, before the pump is actually **turned “OFF”**.

“PRE – PRESSURIZING TIME”  
CLICK ON CELL AND ENTER  
THE TIME DESIRED (IN SECONDS)

Pump	Capacity	Priority	Log(hrs)
1	150	1	
2	350	2	

OPERATING “HOURS” ARE POSTED HERE

“POST – PRESSURIZING TIME”  
CLICK ON CELL AND ENTER  
THE TIME DESIRED (IN SECONDS)

THE OPERATION LOG (IN HOURS) CAN BE  
“ERASED” BY CLICKING ON THE “ERASE”  
BUTTON FOR THE DESIRED PUMP

## PRIORITIES :

A “**PRIORITY**” can be entered for each Pump. The Priority establishes in what order each pump will be put into Operation. If Two (2) or more pumps are given the **SAME** Priority number – then these pumps will **ALTERNATE** as to which will start **FIRST** one time and then the other the next time, etc.

Normally a Priority Number (the same as the pump number) is entered automatically. This of course can then be changed to what ever priority you wish for each of the pumps.

Once you have all the pump data entered correctly – then **CLICK** on the **OK** button to enter the data permanently.

**YOUR SYSTEM IS NOW PROGRAMMED FOR THE PUMP STATION OPERATION.**

## **Rain Sensor for “Shut Down” of Irrigation System upon a pre-determined amount of Rain Fall:**

The system is capable of incorporating a “RAIN SENSOR” for “SHUTTING DOWN” the Irrigation System. The system is checking continuity and therefore only looking for the action of a “DRY SWITCH” on the sensor (*NO Voltage involved*).

Normal MAXI cable can be used from the Rain Sensor back to the Line Termination Box. The cable connects to the #7 and #8 Sensor Terminals on the left end of the terminal strip. **Refer to FIGURE: 6.4 shown below.**

The Sensor Switch Action may be either “ON” (switch “closed”), which is referred to as “Normally Open” – N.O. or may be “OFF” (switch “open”), which is referred to as “Normally Closed” – N. C. when the sensor threshold is met. The switch position is specified when the sensor is programmed into the system.

When the Rain Sensor is **ACTIVE** (has the system “Shut Down”), you may operate decoders/valve-in-head sprinklers **MANUALLY** from either the central unit or by use of the field transmitter or FREEDOM system.

## **Pump Alarm Sensor for “Shut Down” Of Irrigation System upon a Pump Failure:**

The system is capable of incorporating a “PUMP ALARM SENSOR” for “SHUTTING DOWN” the Irrigation System. The system is checking continuity and therefore only looking for the action of a “DRY SWITCH” on the sensor (*NO Voltage involved*).

Normal MAXI cable can be used from the Pump Alarm Sensor back to the Line Termination Box. The cable connects to the #9 and #10 Sensor Terminals on the left end of the terminal strip. **Refer to FIGURE: 6.4 shown below.**

The Sensor Switch Action may be either “ON” (switch “closed”), which is referred to as “Normally Open” – N.O. or may be “OFF” (switch “open”), which is referred to as “Normally Closed” – N. C. when the sensor threshold is met. The switch position is specified when the sensor is programmed into the system.

When the Pump Alarm Sensor is **ACTIVE** (has the system “Shut Down”), the Pumps are believed to have a failure and for that reason you may **NOT** operate decoders/valve-in-head

sprinklers **MANUALLY** from either the central unit or by use of the field transmitter or FREEDOM system.

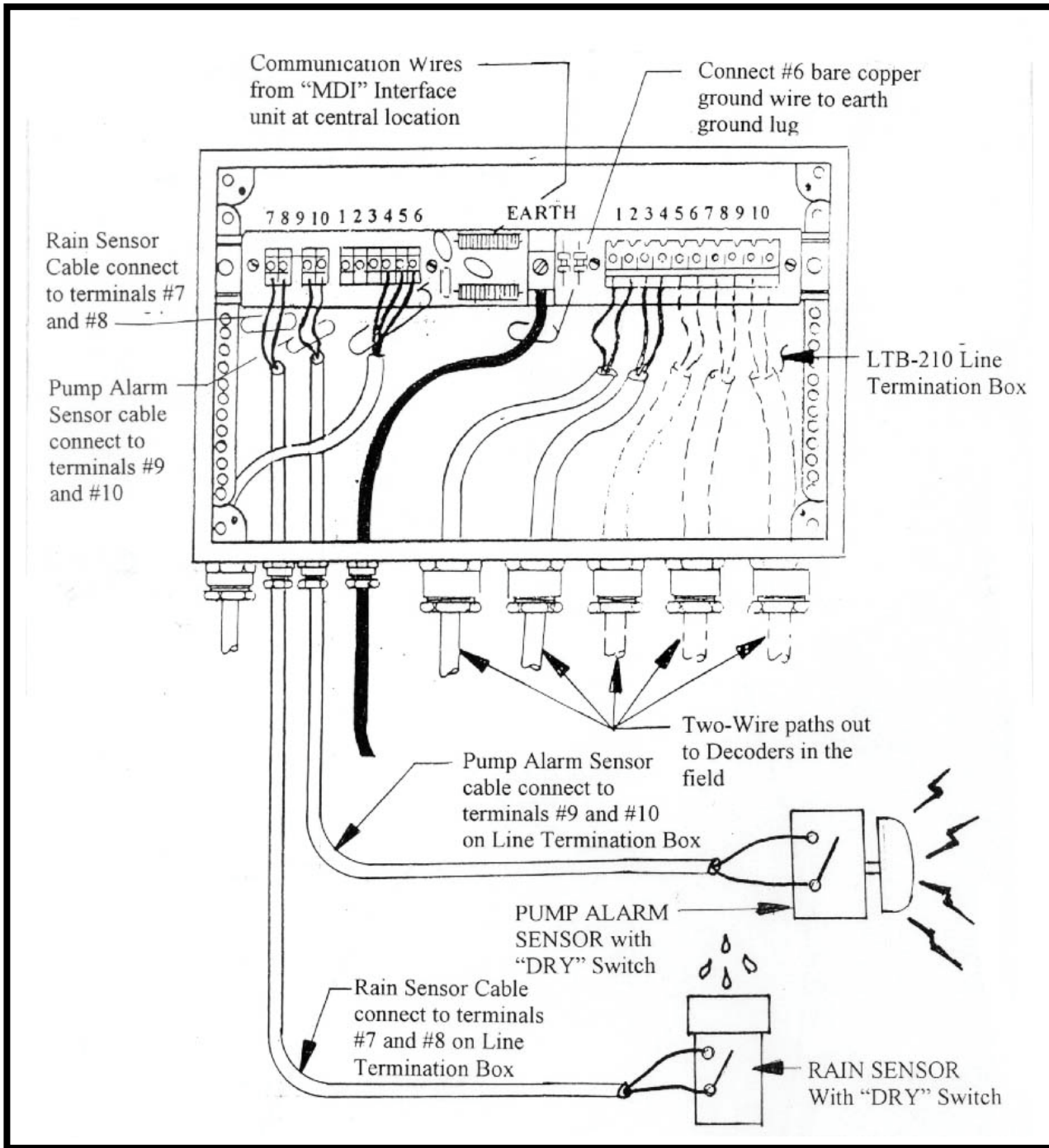

**SENSOR CONNECTIONS TO LINE TERMINATION BOX**  
**FIGURE: 6.4**

## Troubleshooting the Decoder System

*The Two-Way Communication of the Rain Bird Decoder System Provides Powerful Diagnostic Capabilities at the Central Location for Easy Troubleshooting of the System.*

Troubleshooting is an art. But it is based on a logical sequence of thought. In this section, troubleshooting guidelines will be presented. Using these trouble-shooting procedures, the Decoder system is easy to service and maintain.

This chapter is broken into two sections. All troubleshooting of a Rain Bird Decoder System should start at the CENTRAL LOCATION. This will be the first section of this chapter. After diagnosing the problem at the Central Location, troubleshooting can then proceed in the FIELD. This will be the second part of this chapter.

### Troubleshooting from the Central Location

Troubleshooting of a Decoder System at the Central Location entails using the Rain Bird Decoder System Diagnostics. The Software programs have a *Decoder Diagnostics* function that enables the software to perform diagnostics on the decoders and the Two-Wire Communication Path. These Decoder Diagnostics can be used alone without a Line Test unit as the software puts the interface unit (MDI, LDI or SDI) into a current limiting mode when the diagnostics are brought on line and the interface unit is placed in a 60 Hz mode for troubleshooting the system. In this section, diagnostic testing will be discussed using the Decoder Diagnostics. Finding field

faults will require the use of a sensitive clamp meter capable of reading as little as a few milliamps (mA). Contact you Rain Bird Golf Distributor for details.

# **DECODER DIAGNOSTICS - USING STRATUS, STRATUS II, NIMBUS, NIMBUS II or CIRRUS SOFTWARE**

There are **SIX** tests that can be run on the Decoder System, by using the software, and which facilitate troubleshooting of the system. These tests can be run by using the STRATUS, STRATUS II, NIMBUS, NIMBUS II or the CIRRUS software in conjunction with the MDI Interface Unit and do not require any additional equipment. These are different tests from those tests run by the Line Test Unit only, but the results should be used in conjunction with the Line Test Unit results to pinpoint problems in the field.

To access the Decoder System **DIAGNOSTICS**, you need to start at the **FRONT OFFICE** screen of the particular software you are using.

**STEP #1: CLICK ON #3 ICON**  
FRONT OFFICE SCREEN



CLICK ON THE #3 ICON

The third group of Icons will now be displayed as shown below.

**STEP #2: CLICK ON "PASSWORD" ICON**

#3 GROUP OF ICONS BEING DISPLAYED

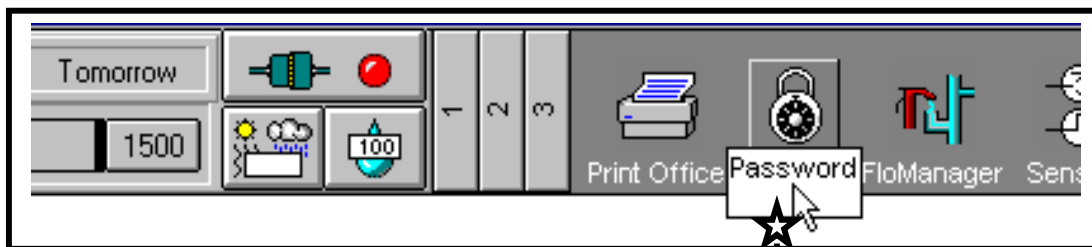

CLICK ON THE "PASSWORD" ICON

**STEP #3: ENTER PASSWORD "4321"**

The system will now ask for you to enter the "Password", which is "4321".

After entering the "Password"  
Then Press <ENTER>

ENTER "4321" (Password)

THEN PRESS <ENTER>

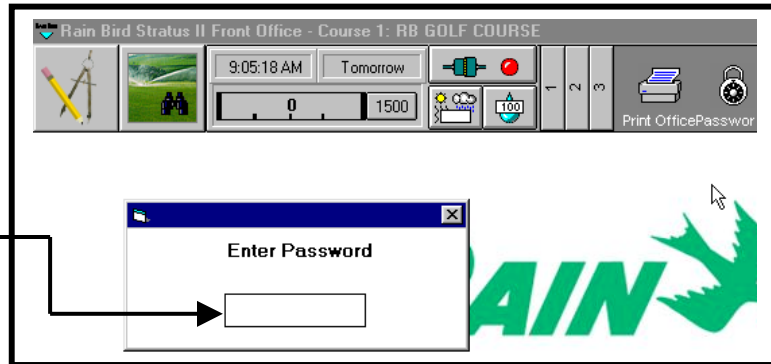

**STEP #4: CLICK ON "PASSWORD" ICON**

Padlock is "Unlocked" and "PASSWORD" Icon is displayed

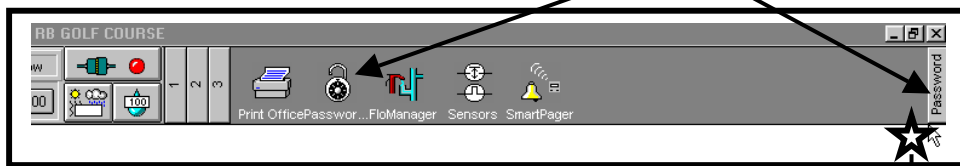

CLICK ON "PASSWORD" ICON

Click on the "PASSWORD" Icon at the top, far right side of the screen.

**STEP #5: CLICK ON THE "DECODER" ICON**

The following ICONS will now be displayed on the right side of the header screen.

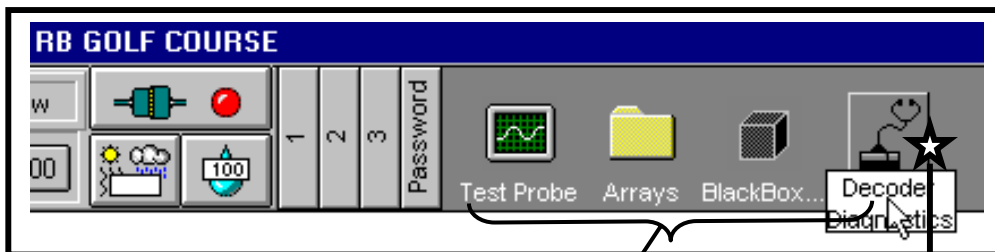

NEW ICONS NOW DISPLAYED

CLICK ON THE "DECODER" ICON

Click on the "DECODER" Icon now being displayed.

The first Decoder Diagnostics screen will now be displayed, as shown below.

**SIX DECODER DIAGNOSTIC TESTS AVAILABLE**

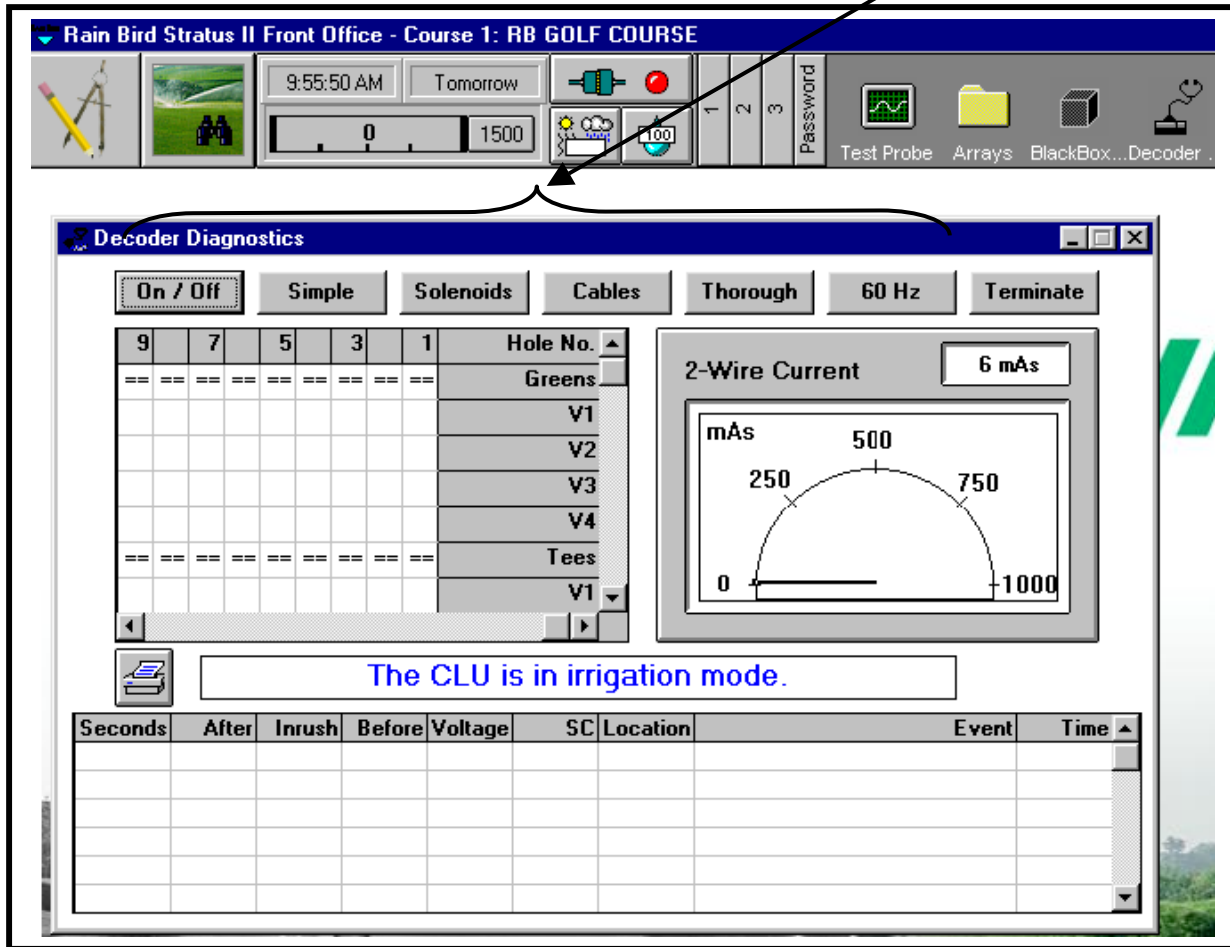

**RUNNING THE DECODER DIAGNOSTIC TESTS:**  
**(Tests MUST be run in sequence)**

As you see from the screen displayed above, there are six (6) TESTS in the decoder diagnostics window. These six tests should always be **performed** in their **PROPER SEQUENCE** because the results from previous tests are used to interpret the results of subsequent tests. The first few tests look for very general problems while the latter tests look for very specific problems. The latter tests cannot be performed until after all of the problems found during the earlier tests have been resolved.

**TEST #1: ON/OFF DECODER TEST**

On / Off

**OBJECTIVE:** To determine whether or not each decoder will respond to the standard “ON” command.

This test is useful for determining which decoders will respond properly during irrigation, but it does not indicate any degradation of the decoders or the lines.

**PROCEDURE:** Each decoder is sent its usual switchcode and an “ON” command. - *Bear in mind, if you are checking a system which is pressurized, the valves will be activated briefly.*

The current in the two-wire path is measured before, during and after the activation of the decoder to determine whether or not the decoder responded to the “ON” command. Each decoder is then turned “OFF”. The decoders that did not respond to the “ON” command will be tagged with an “F” in a “RED” background field, to indicate that they **FAILED** this test. The decoders that did respond to the “ON” command will be tagged with a “P” in a “GREEN” background field, to indicate that they **PASSED** this test.

INDICATES DECODER “FAILED” THE TEST  
 (“F” in a red background cell)

The On / Off Decoder Test has been completed.

Seconds	After	Inrush	Before	Voltage	SC	Location	Event	Time
					59FA50	2G1	Turned on decoder.	12:09:29
	6	7	7			2G1	Three current samples.	12:09:31
							Turned off decoder.	12:09:31
							DECODER FAILED!	12:09:32
					59FA50	2T1	Turned on decoder.	12:09:33
	1127	1126	6				Three current samples.	12:09:35

NEITHER “INRUSH” OR “AFTER” CURRENT EXCEEDED THE “BEFORE” CURRENT – THUS DECODER “FAILED” THE TEST  
 INDICATES DECODER “PASSED” THE TEST

**DETAILS:** Three current samples are taken at 40 millisecond intervals.

The first sample is the “BEFORE” current. The second sample is the “INRUSH” current. The third sample is the “AFTER” current. ***IF EITHER THE “INRUSH” or THE “AFTER” CURRENT EXCEEDS THE “BEFORE” CURRENT BY 25 mA or MORE, THEN THE DECODER “PASSES” THE TEST.*** Otherwise, the decoder fails.

**COMMENTS:** During the test, each decoder receives the same information that it receives during irrigation.

This test simply tells us whether or not each decoder can be turned “ON” and “OFF”. There are NO warning messages displayed during this test, other than the “DECODER FAILED” notation in the data recording area of the test window.

**CAUSES for DECODER FAILURE:**

There are six (6) possible causes for a decoder to fail the ON/OFF test.

- 1<sup>st</sup>** – Check and double check the decoder **ADDRESS**. A number inadvertently written down incorrectly or perhaps a missed keystroke during data entry will cause a decoder to **FAIL**.
- 2<sup>nd</sup>** – On a new system “start-up”, ***missed or poorly made*** wire SPLICES, are the cause of most decoder **FAILURES**. A missed mainline splice, as at a three-way branch location, will cause any decoder that is “downstream” from that point to **FAIL**. These are very easy to locate with a good “as-built” plan of the system layout. Remember **ALL SPLICES** must be located properly in valve boxes for easy accessibility.
- 3<sup>rd</sup>** – Missed or poorly made wire splices at the decoders will also cause a decoder to **FAIL**. Both the ***BLUE communication wires*** from the decoder to the MAXI communication cable and the ***WHITE output wires*** from the decoder to the solenoid coil **MUST** be twisted, then wire nutted and finally placed in a DBY or DBR splice kit.
- 4<sup>th</sup>** – If there is secondary wiring used between the decoder output and the valve solenoid coil, it must be checked for **continuity** and/or ***resistance*** to assure a good circuit from the decoder to the valve and back.

If you have checked the secondary wiring from the point where it is spliced to the decoder output wires and have an “**open**” indication, then check the solenoid itself. If it is fine, then the problem is either a bad splice at the solenoid or a broken secondary wire, which will then need to be traced by using a fault finder on it.

**5<sup>th</sup>** – The **SOLENOID** itself may be “open”, which will cause a decoder that is actually working, to give a false “**FAIL**” indication.

**6<sup>th</sup>** – Lastly, the **DECODER** itself may be “bad” and simply not function.

***ALL OF THESE POSSIBILITIES MUST BE EXPLORED AND CORRECTED.***

**ACTION TO BE TAKEN:** First, check the integrity of the splices, secondary wiring and the solenoid itself. If all are fine, then decoders that failed this test are **NOT** suitable for irrigation and should be replaced at this time.

If the warning message “**EXCESSIVE CURRENT DETECTED**” is displayed at the beginning of this test, then there is most likely a problem somewhere in the two-wire path. The user should **CONTINUE** this test and check to see if there is a group of decoders in a particular area that all fail this test. If so, the user should check the wires in that region. Otherwise, the user should put the MDI into a 60 Hz mode and inspect the two-wire path with a clamp meter to find the short or leakage. The excessive current problem **MUST** be resolved before test #3, #4 & #5 can be performed.

## **WARNINGS:**

A failure in the “SIMPLE DECODER TEST” can indicate a number of things. It may mean that the decoder has been damaged by a voltage surge, but more likely, a failure indicates a problem in the wiring between the two-wire path, the decoder, and the solenoid.

The first step is to check the integrity of the two-wire path’s connection to the decoder itself. These splices must be intact and must **NOT** be leaking to ground. If the splices are **NOT** intact, the decoder will not be powered correctly and therefore cannot be controlled by the MDI Interface unit. The decoder itself can be checked simply by connecting it in place of another good decoder and running the “Simple Decoder Test” again.

If a decoder that is functioning correctly fails the “Simple Decoder Test”, the indication is that there is a problem on the *secondary wire path*, the wiring between the decoder and the solenoid. A decoder will fail if there is a ground fault in one of the splices on the secondary path or if the secondary path is not intact. In either case, the secondary path does not provide an integral path for the current from the decoder to travel to the solenoid to activate it.

A decoder will **NOT FAIL** the “Simple Decoder Test” if the secondary path is **SHORTED**. If the path is shorted, or if the solenoid itself is shorted, the decoder will attempt to power the solenoid, but the solenoid will not activate. However, because the decoder is still functioning, it will **PASS** the “Simple Decoder Test” even if a solenoid is shorted.

## **TEST #2: SIMPLE DECODER TEST**



Simple

**OBJECTIVE:** To determine whether or not each decoder and its solenoid are working properly.

**PROCEDURE:** Before testing each of the decoders, the current in the two-wire path is measured, in order to determine if it is **STABLE** and **BELOW** an acceptable limit.

If the **current** in the two-wire path is **STABLE** and **BELOW** the acceptable limit, then each decoder is activated with a special switchcode that is based upon the resistance of the solenoid that is connected to the decoder. This special switchcode reduces the inrush voltage from standard 35 volts to 26 volts and in effect changes the effective resistance of the solenoid to **45 ohms**. When the decoder is activated, the inrush current will then indicate the solenoid’s resistance. If the **resistance** is **less than** or **greater than 45 ohms**, the inrush current won’t be measured by the MDI, which is looking for a minimum of 25mA. The solenoid has either been damaged by lightning or has a mechanical problem. The decoders that respond properly to this special switchcode are tagged with a “P” displayed on a “GREEN” background, indicating that they have **PASSED** this test. The decoders that did **NOT** respond properly to this special switchcode are tagged with an “F” displayed on a “RED” background, indicating that they have **FAILED** this test.

INDICATES DECODER "FAILED" THE TEST  
 ("F" in a red background cell)

INDICATES SIMPLE DECODER  
 TEST IS IN PROGRESS

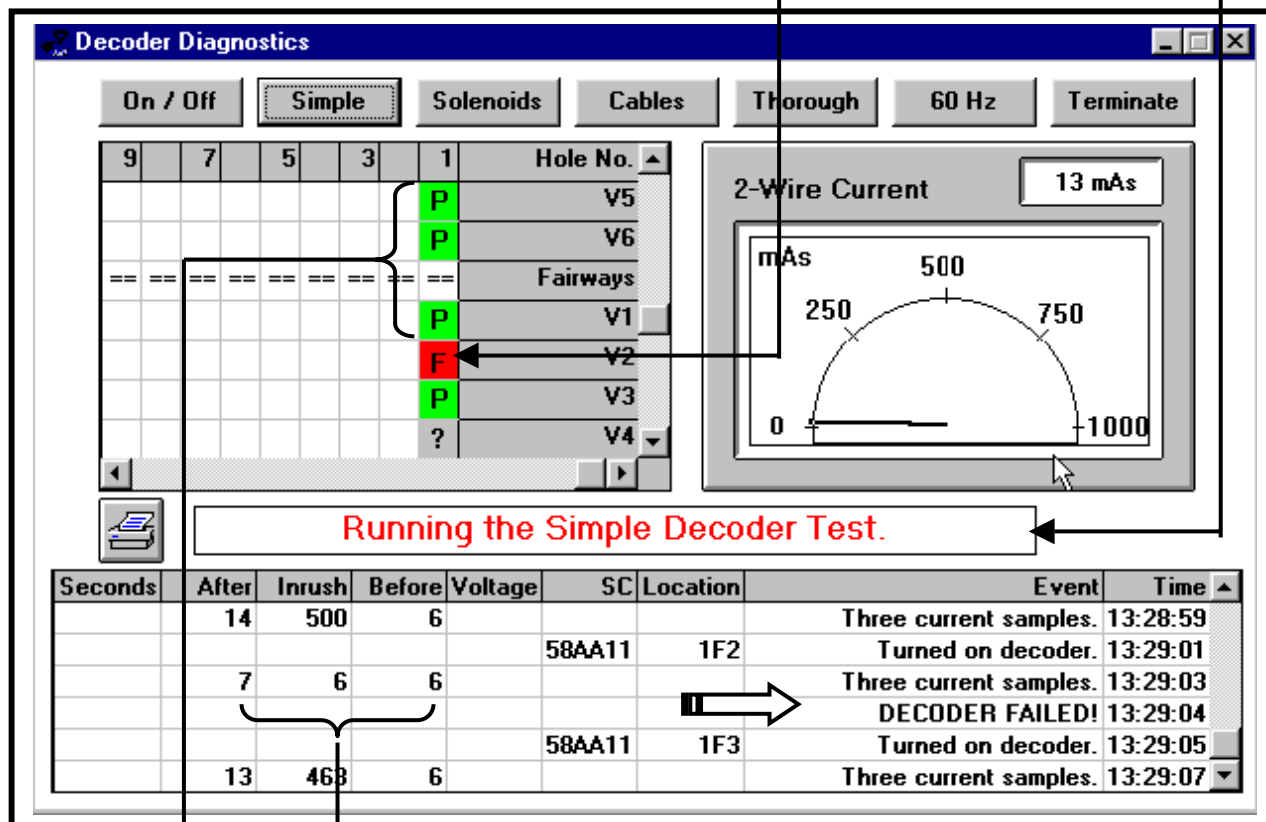

Running the Simple Decoder Test.

CURRENTS INDICATE DECODER "FAILED"

INDICATES DECODER "PASSED" THE TEST  
 ("P" in a green background cell)

**DETAILS:**

Before beginning this test, the current in the two-wire path is checked.

**GIVEN:** Let "X" = the number of FD-210/FD-102 type decoders on the system.

Let "Y" = the number of FD-410/FD-202, FD-401 and/or FD-610/FD-601 decoders on the system.

**FORMULA:**  $I_{\text{Acceptable}} = [(\text{"X"} \times 0.5 \text{ mA}) + (\text{"Y"} \times 1.0 \text{ mA})] \times 1.25 + 100 \text{ mA}$

Single CHANNEL Decoders (FD-210/FD-102) theoretically draw a nominal current of 0.5 mA of current.

Multiple CHANNEL Decoders (FD-410/FD-202, FD-401 and FD-610/FD-601) theoretically draw 1.0 mA of current.

The factor 1.25 allows for a 25% error of margin. The 100 mA is the limit of excessive current consumption. If the current in either line of the two-wire path EXCEEDS this limit, then a warning message will be displayed, as shown below.

## **“EXCESSIVE CURRENT DETECTED”**

**If there is excessive current, it is usually the result of a short in the line or a short in a decoder, or excessive leakage to ground by either a FAULT in the two-wire path or leakage to ground by a decoder.**

After the current in each of the lines has been measured, each decoder will be activated with a special switchcode. During the activation, five current samples are taken at 60 millisecond intervals. The *first* sample is the “BEFORE” current. The MAXIMUM of the *second*, *third* and *fourth* samples is taken as the “INRUSH” current. The *fifth* sample is the “AFTER” current.

Let “X” = the number of decoders (both single and multiple channel type) on the two-wire path.

**A DECODER “PASSES”** the test if . . .

$$I_{\text{Inrush}} < 1050 \text{ mA}$$

**and**

$$I_{\text{Inrush}} > 300 \text{ mA} + [0.5 \text{ mA} \times (\text{“X”} - 250)]$$

**and**

$$I_{\text{After}} > I_{\text{Inrush}} - 50 \text{ mA}$$

**COMMENTS:** This test can only be performed on decoders that have solenoids with a resistance of 50 ohms or less.

**ACTION TO BE TAKEN:**

Failure of this test indicates that either the decoder or its solenoid is damaged. If a decoder and its solenoid fail this test, then you should run the next test, “Grounded Solenoids Test”, to determine if the problem is in the decoder or in the solenoid.

If a group of decoders, all in the same area fail this test, then the problem is most likely Damaged lines in that region rather than in the decoders themselves. Therefore the lines in that area should be checked with a clamp meter.

If a group of decoders in the same area fail this test due to low current consumption, then the problem may be due to a bad connection in the two-wire path, which is causing excessive resistance in the lines. If this is the case, the two-wire path should be inspected with a clamp meter.

**TEST #3: GROUNDED SOLENOID TEST**

Solenoids

**OBJECTIVE:** To determine if any of the solenoids are leaking excessively to ground.

This test is useful for determining the severity of a solenoid’s leakage to ground.

**PROCEDURE:** Each decoder is reprogrammed to address “0000”.

INDICATES DECODER HAVING BEEN RESET TO ADDRESS "0000"

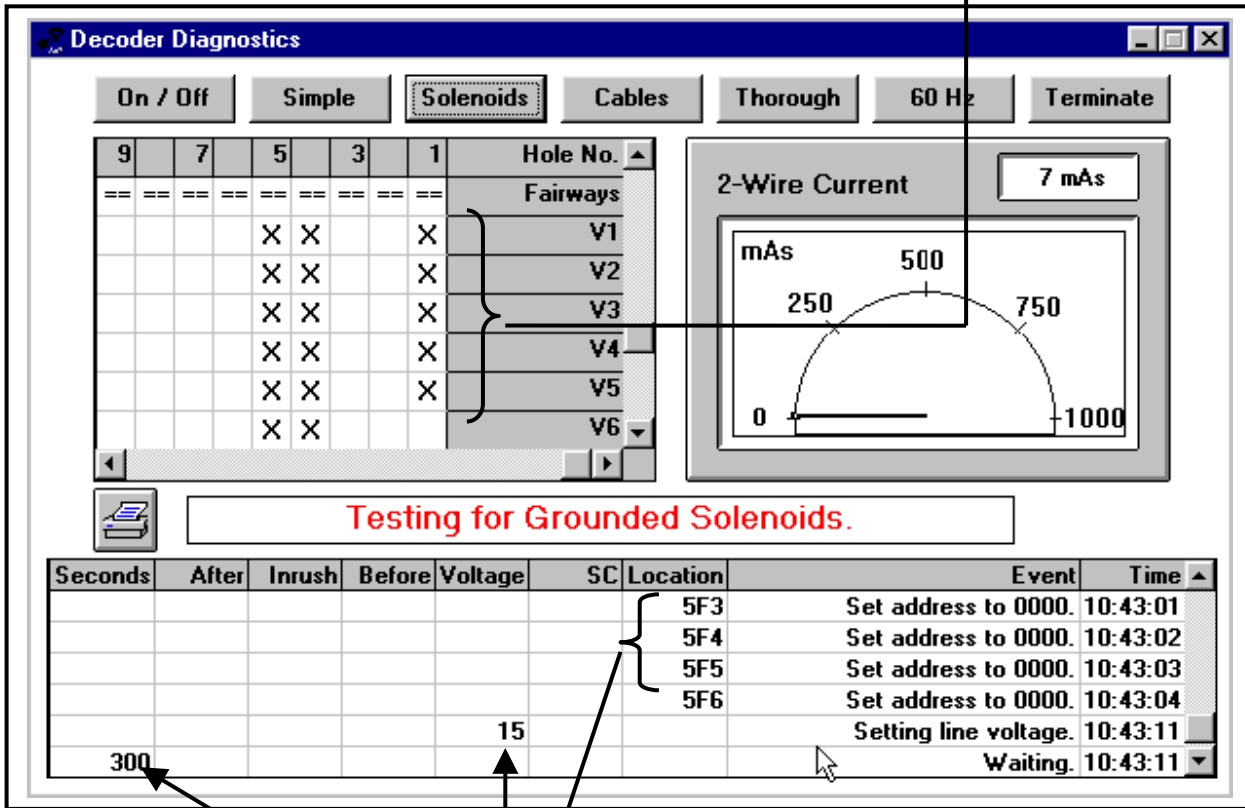

INDICATES WAIT TIME PERIOD

INDICATES DECODER HAVING BEEN REPROGRAMMED TO ADDRESS "0000"

TEST VOLTAGE SELECTED

After each decoder has been reprogrammed to address "0000" & with the two lines of the 2-wire path clamped together, then the specified test voltage (15 volts, 25 volts, or 35 volts) is applied for a period of five minutes (refer to screen displayed above).

During this time, only the decoders with solenoids that leak excessively to ground will be able to maintain their new address of "0000" sue to the leadage current continuing thru the decoder and not allowing the code to be reset on return of the normal line condition. The decoders with solenoids that do NOT leak excessively will lose their new address of "0000" and will automatically be reset to their original addresses on return of the normal line conditon. After the five minute wait has been completed, the lines will be reactivated and then each decoder will be tested to see if it responds to its original address. Those decoders that do not respond have solenoids that are leaking excessively to ground and will be tagged with an "F" on a RED background, indicating that the decoder has "FAILED" this test. Those decoders that have been tagged with a "P" on a GREEN background are indicating that the decoder has "PASSED" this test.

**INDICATES THAT THIS DECODER HAS "FAILED" THE TEST**  
 (Tagged with an "F" on a RED background cell)

**INDICATES THIS DECODER HAS "PASSED" THE TEST**  
 (Tagged with a "P" on a GREEN background cell)

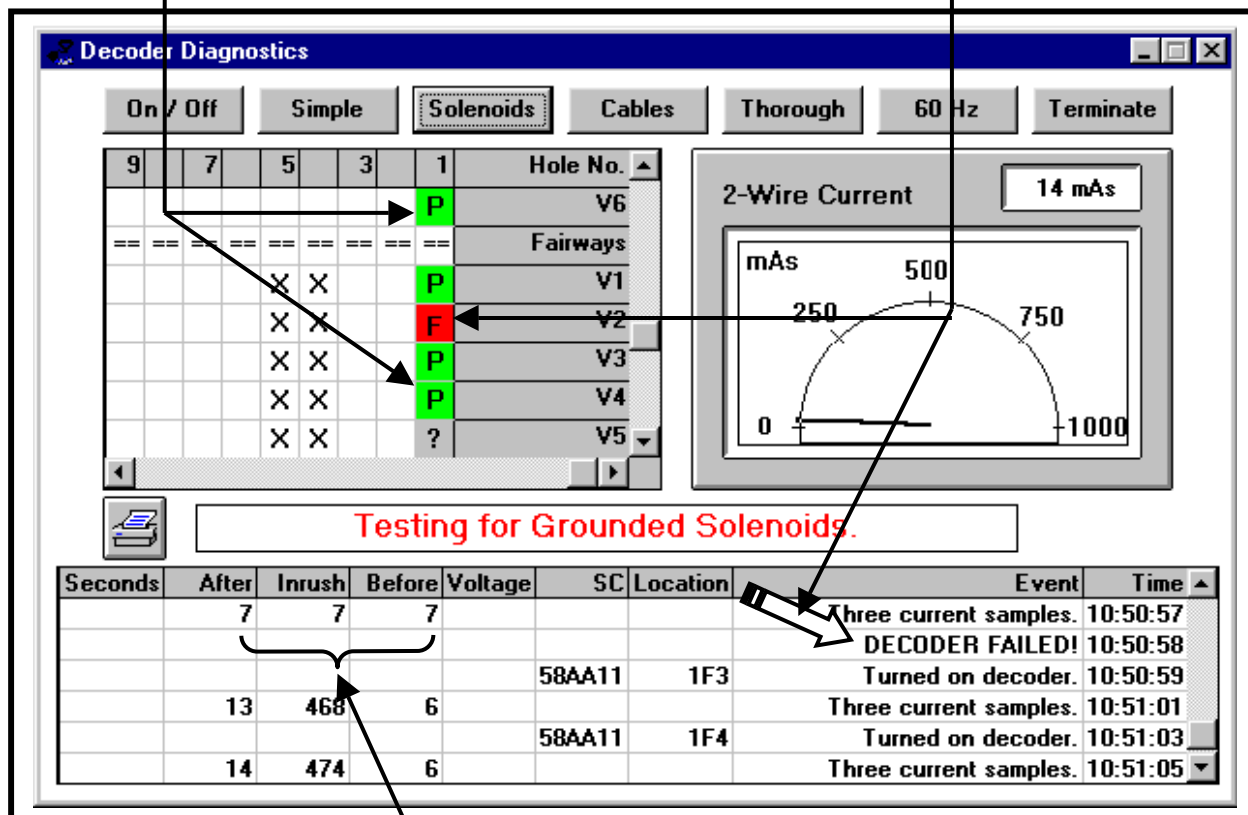

**CURRENTS INDICATE DECODER HAS "FAILED" THIS TEST**

If any of the decoders fail this test, then the two-wire path will be tristated for a period of three (3) minutes. (Refer to the screen displayed on the next page.) During this time, the decoders that still have an address of "0000" will go through an automatic reset and will then respond to their original addresses.

**DETAILS:** Three test voltages are available so that the user may distinguish those decoders with solenoids that are leaking excessively to ground from the decoders with solenoids that are leaking only slightly.

INDICATES DECODER THAT HAS "FAILED" THIS TEST  
 (Tagged with an "F" on a RED background cell)

The screenshot shows the 'Decoder Diagnostics' window with the 'Solenoids' tab selected. The test results table is as follows:

Hole No.	9	7	5	3	1	Fairways
V1			P	P	P	
V2			P	P	F	
V3			P	P	P	
V4			P	P	P	
V5			P	P	P	
V6			P	P	P	

The 2-Wire Current graph shows a semi-circular curve with a peak at 500 mA. The x-axis is labeled 'mAs' with values 0, 250, 500, 750, and 1000. The y-axis is labeled 'mAs' with a value of 6. A status message at the bottom reads: "The Grounded Solenoids Test has been completed." The event log at the bottom right shows the following sequence:

Seconds	After	Inrush	Before	Voltage	SC	Location	Event	Time
					58AA11	5F6	Turned on decoder.	10:53:37
	13	496	6				Three current samples.	10:53:40
							Tristating the lines.	10:53:43
							Waiting.	10:53:43
							Setting to max current.	10:56:44
							Finished with the test.	10:56:44

INDICATES WAIT PERIOD

INDICATES TWO-WIRE PATH BEING TRISTATED

Decoders that **FAIL** at the low test voltage of **15 volts** have solenoids that are leaking excessively to ground. Decoders that **PASS** at the low test voltage of **15 volts** but **FAIL** at the high test voltage of **35 volts** have solenoids that are leaking only slightly to ground.

After the two-wire paths have been locked at the specified voltage for five (5) minutes and then reestablished for one minute, the "SIMPLE DECODER TEST" is performed. *Refer to the section for "TEST #2: SIMPLE DECODER TEST" for interpretation of the test results.*

### **ACTION TO BE TAKEN:**

If a Decoder FAILS this test, then the electrical connections from the decoder to its solenoid should be inspected. If the connections are leaking to ground, then the connections should be repaired. Otherwise, the solenoid itself is leaking and it must eventually be replaced.

Decoders that FAIL this test at 15 VOLTS should have their solenoids and connections inspected at the next convenient opportunity.

Decoders that FAIL this test at 35 VOLTS have solenoids that are still functioning satisfactorily but they should be tested more frequently in case there is further degradation.

## **TEST #4: GROUNDED CABLES TEST**

Cables

**OBJECTIVE:** To determine if either wire in the two-wire path is leaking excessively to ground.

This test is useful after the system has been struck by lightning or the wires have been serviced.

**PROCEDURE:** The current in each of the wires of the two-wire path is measured to determine if it is stable and within a specified range.

If the currents in both lines are stable and within the acceptable range, then the current in the ground line is measured and the voltage at the case is measured. If either the current or voltage is not within the specified range, then the user is warned of an error condition.

INDICATES THAT "TESTING FOR GROUNDED CABLES" IS IN PROGRESS

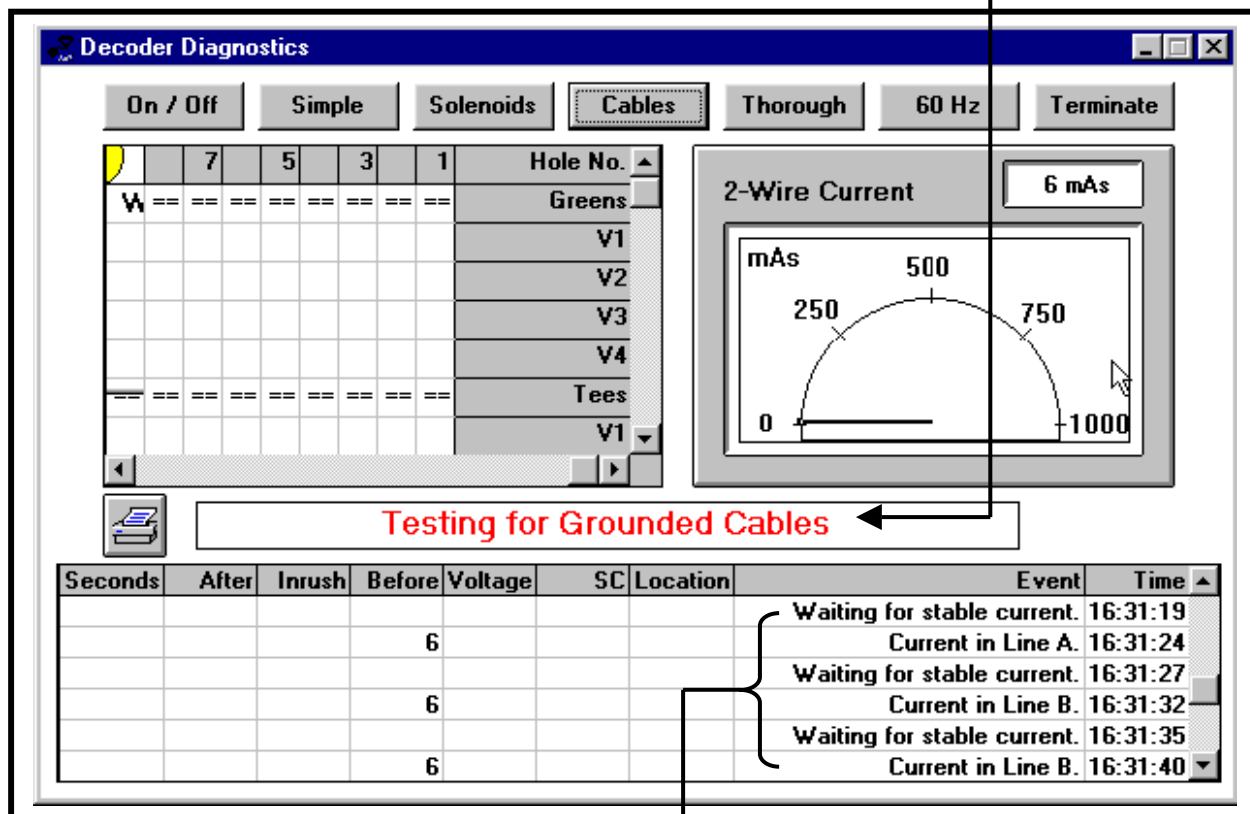

CHECKING CURRENT IN BOTH LINES "A" & "B" OF THE TWO-WIRE PATH

**DETAILS:** The lines of the two-wire path are locked – Line "A" is locked "HIGH" and Line "B" is locked "LOW".

With the lines of the Two-wire path now locked, with line "A" locked "HIGH" and line "B" locked "LOW" – the system takes two sets of three (3) current samples. The average of each set of samples is calculated and then the difference between the two averages is determined. If the difference is **LESS than 5 mA**, then the current is considered **STABLE**.

Then the lines are reversed and locked, with line "A" locked "LOW" and line "B" locked "HIGH" – the system again takes two sets of three (3) current samples. The average of each set of samples is calculated and then the difference between the two averages is determined. If the difference between the first average and the second average is **LESS than 5 mA**, then the current is considered **STABLE**.

The **maximum** theoretical current consumption in each line of the two-wire path is calculated by:

$$I_{\text{Line}} = [(\text{"X"} \times .5 \text{ mA} + \text{"Y"} \times 1.0 \text{ mA}) \times 1.25 ] + 10 \text{ mA}$$

**Where: "X" = Number of Single Channel Decoders**  
Such as: FD-210/Fd-102 Decoders

**"Y" = Number of Multiple Channel Decoders**  
Such as: FD-410/FD-202, FD-401 &  
FD-610/FD-601

If the current in either line exceeds this value, then the user is warned about **"EXCESSIVE LINE CURRENT"**.

The **Minimum** theoretical current consumption in each line of the two-wire path is calculate by:

$$I_{\text{Line}} = [(\text{"X"} \times .5 \text{ mA} + \text{"Y"} \times 1.0 \text{ mA}) \div 1.25] - 10 \text{ mA}$$

**Where: "X" = Number of Single Channel Decoders**  
Such as: FD-210/Fd-102 Decoders

**"Y" = Number of Multiple Channel Decoders**  
Such as: FD-410/FD-202, FD-401 &  
FD-610/FD-601

If the current in either line is below this value, then the user is warned about **"INSUFFICIENT LINE CURRENT"**.

**COMMENTS:**

**Before running this test it is imperative that all of the decoders in the system passed the previous test at 15 Volts.**

If all of the decoders passed the previous test, then we know that they are not leaking excessively to ground. Therefore, if this test indicates that there is excessive leakage, we know the leakage must be from the lines rather than from the decoders.

**WARNING MESSAGE:**

So if the message “**Warning: Excessive current detected**” is displayed, then there is leakage either from a wire to ground or from one wire to the other wire in the two-wire path.

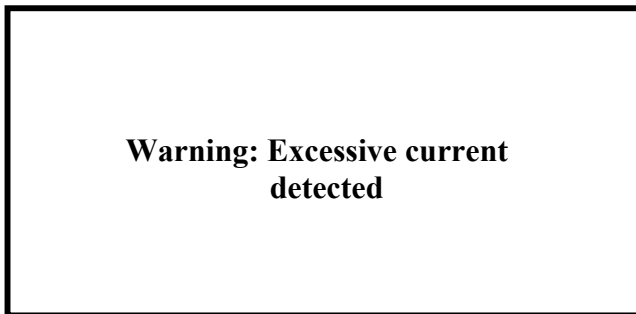

**ACTION TO BE TAKEN:**

The 60 Hz mode test should then be used, in conjunction with the Clamp Meter to find the location of the leakage.

**WARNING MESSAGE:**

There is another warning message that may be displayed – “Warning: Insufficient Current Detected”. This message is included only for the sake of completeness; the only time that insufficient current would be detected is if the database includes extra decoders that are not actually connected to the two-wire path.

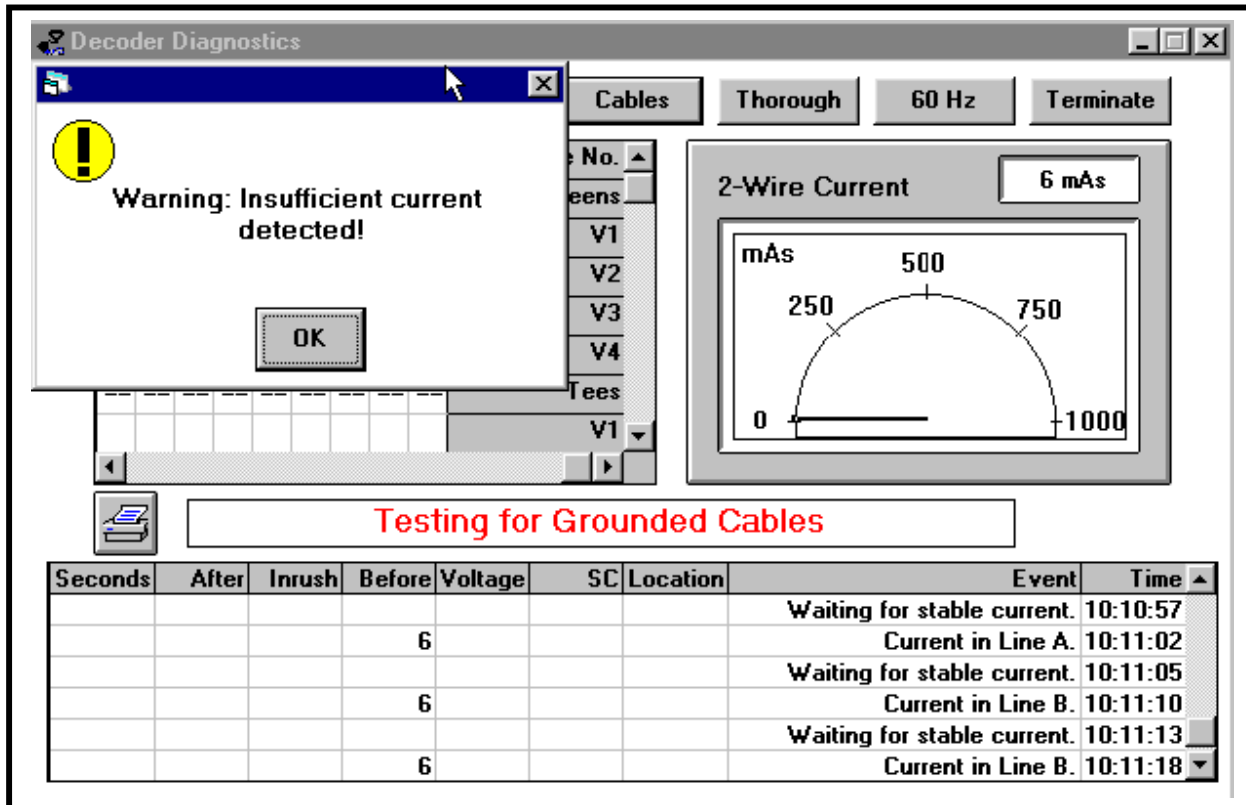

**ACTION TO BE TAKEN:**

NONE

**ADDITIONAL COMMENTS:**

If the current in the ground line exceeds 15 mA, then the message “Warning: Current in Ground Line Exceeds 15 mA” will be displayed. If this message appears, then there is leakage from one of the wires to ground.

**ACTION TO BE TAKEN:**

The 60 Hz test mode should be used, in conjunction with a Clamp Meter to find the location of the leakage and proper correction should be made.

**ADDITIONAL COMMENTS:**

If the voltage on the ground line exceeds 17.5 volts, then the message “Warning: The Voltage at the Case Exceeds 17.5 Volts” will be displayed.

This situation can be caused either by very heavy leakage from a wire to ground, or by a problem with the MDI Interface Unit.

### **ACTION TO BE TAKEN:**

If the current in the ground line was reported as excessive, then the problem is due to leakage from the ground wire.

**The 60 Hz test mode should be used, in conjunction with a Clamp Meter to find the location of the leakage and proper correction should be made.**

**This problem should be solved IMMEDIATELY because it will cause corrosion to the cables.**

If the current in the ground line was *NOT HIGH* and this warning message is displayed;

**The two-wire path should be disconnected from the MDI Interface Unit and this test should be run again.**

**If the voltage at the ground line is still HIGH, then the MDI Interface Unit is defective.**

## **TEST #5: THOROUGH DECODER TEST**

**Thorough**

**OBJECTIVE: To determine if the internal current consumption of each decoder is low enough to insure that the capacitor in the decoder will be capable of activating the solenoid.**

This test is useful for identifying decoders with deteriorating hardware. Decoders that fail this test may still operate properly during irrigation, but they should be replaced due to imminent failure.

**PROCEDURE: Each decoder is sent a special switchcode, which is calculated from the decoder's solenoid resistance.**

This switchcode is the same one that was described previously in the “Simple Decoder Test”. After sending all of the switchcodes, the line voltage is truned “OFF” for 20 seconds. During this 20 second wait, the decoders that have excessive internal current consumption will not be able to maintain the special switchcodes. After the 20 seconds have elapsed, the lines are reactivated and the system waits for 60 seconds to let the lines power up and stablize. Then each decoder is sent an “ON” command without a switchcode. The decoders that fail to respond to this “ON” command have lost their swtichcodes so they are tagged with an “F” on a **RED** background cell, indicating that their internal current consumption is too high.

**DETAILS:**     **The normal current consumption of a single channel decoder is 0.5 mA and the normal current consumption of a multiple channel decoder is 1.0 mA.**

If the internal current consumption of a decoder exceeds 15 mA, then when the line voltage is turned off for 20 seconds, the capacitor will be discharged to a voltage that is too low to maintain the decoder’s switchcode. Therefore, the decoder will lose its switchcode and will NOT respond to the “ON” command. After the line voltage had been turned off and then reactivated, the “Simple Decoder Test” is performed. (*Refer to Section for Simple Decoder Test – Test #2*).

**TEST #6: 60/50 Hz TEST**

**60 Hz**

**OBJECTIVE:**     **To assist the user in finding shorts in the two-wire path and leakage from wire to wire or from wire to ground.**

**PROCEDURE:**     The user puts the MDI Interface Unit into the 60/50 Hz mode and then inspects the two-wire path at various points with a Clamp Meter. The Clamp meter will show where the signal in the two-wire path is active and where the signal is being lost due to either shorts in the cable or from leakage to ground.

**COMMENTS:**     The MDI Interface Unit communicates with the decoders on the two-wire communication path through an approximate 34 Volt AC signal. The AC signal is used to prevent corrosion of the two-wire path. The AC signal is normally alternating at a frequency of 1 Hz, meaning it switches from positive to negative once every second, which is the RED to GREEN alternating you see on the MDI’s “Field” LED.

To measure the current on the two-wire path for troubleshooting in the field a Clamp Meter is used. The frequency of the AC signal must then be increased by the MDI Interface Unit in order to allow the Clamp Meter to measure the signal. When running the 60 Hz Mode test, the AC **signal** is changed from a 1 Hz signal to a 60 Hz signal. In the 60 Hz mode, the MDI cannot communicate with the decoders, so no irrigation can take place. Therefore, upon completing this test, it is important to **TERMINATE** the test and thus return the MDI to the **“NORMAL IRRIGATION MODE”**.

The 60 Hz Mode is started by clicking on the 60 Hz ICON in the Decoder Diagnostics screen. When the MDI Interface Unit is in the 60Hz mode, the “Field” LED will appear an ORANGE color as the AC signal is not at 60 cycles per second.

**CLICK ON 60 Hz ICON**

The current of the MDI can then be measured in the field using the Clamp Meter.

**THE 60 Hz MODE CAN THEN BE CANCELLED BY “CLICKING” ON THE “TERMINATE” ICON**

**THE SYSTEM HAS NOW BEEN PLACED BACK INTO THE “IRRIGATION MODE”**

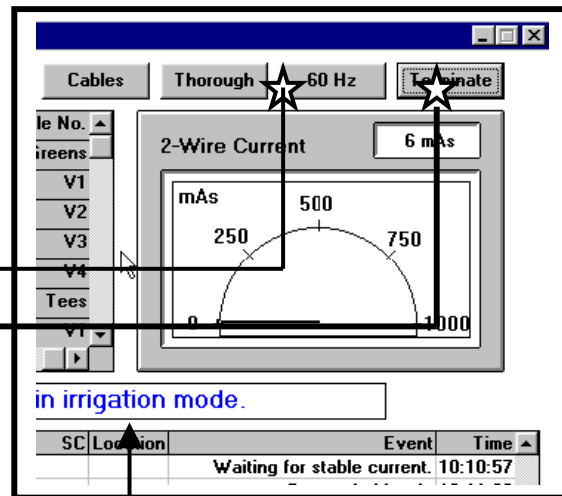

**IMPORTANT!** Since **NO Irrigation** can take place while in the 60 Hz mode – it is extremely important that you place the system back into the “Irrigation Mode” when finished with the field troubleshooting.

# Troubleshooting in the Field

After running the Decoder Diagnostics tests from the Central Software, the troubleshooter should have a general idea of where the problem is in the field. The next thing to do is to form a strategy about how to attack the field layout to track down the problem. When a logical troubleshooting strategy is followed, diagnosing and fixing a field problem is made much easier and with the least amount of time involved in doing so.

**TROUBLESHOOTING TOOLS:** It is very important to have the correct tools to troubleshoot a decoder system.

1. An “AS BUILT” construction *drawing* of the decoder system, accurately showing all two-wire path layouts and all decoders, with their channel addresses recorded for each.
2. A print out of all decoder *addresses* and their locations.
3. A Multimeter capable of measuring minimum voltage of from “0” to **50 Volts, AC/DC** and a resistance of from “0” to “**1 MΩ**”.
4. A Clamp Meter for measuring minimum AC current with a precision of **1.0 ma**. (Refer to Clamp Meter SPECIFICATIONS given at the end of this section)
5. Wire locator (if an accurate “AS BUILT” drawing is not available).
6. Fault Finder for locating broken or nicked wires.
7. Spare Decoders, solenoids, wire and wire splice kits.

These tools will all be used in addition to screwdrivers, pliers, wire cutters, wire strippers, and other general maintenance tools.

**TECHNIQUES for TROUBLESHOOTING:** In troubleshooting a decoder system, it is important to use a technique that leads to the problem and minimizes time spent in doing so. The most important thing to remember is to form a strategy before heading to the field. This strategy should be formed on the basis of the tests that are run at the central location, to narrow down the area in which the problem lies. If the Decoder Diagnostics indicate a problem with a number of decoders all on one two-wire path, focus the troubleshooting effort on that two-wire path. Using a little *common sense* will be the greatest time-saver in troubleshooting.

Having multiple wire paths coming into the Line Termination Box, LDI or SDI, can save a great deal of time, by allowing you to quickly isolate the wire path that may have damaged wire or

damaged decoders on it. It is also critical to know the number of single and multiple address decoders on each individual wire path and the respective “at rest” current draw for each individual wire path, so that you can quickly determine which path has the problem. Another benefit of multiple wire paths is if there is a system wire path problem, it can be isolated, thus allowing the rest of the golf course to irrigate.

Before leaving the central location, the type of problem should be identified. The tests that can be run using the Decoder System Diagnostics in the software and/or the Line Test Unit will assist you in the diagnosis of the kind of problem that is occurring in the field. Problems in the field, besides being with decoders and/or solenoids themselves, are on the two-wire path and can consist of : wire breaks, skinned wires, faulty splices, etc. which can result in short circuits and ground faults. These types of problems will be explored further, a little later.

In a LOOP type two-wire path system layout, problems can be occurring on the two-wire path, but because the system is looped, they may only be showing up under certain conditions. If a problem is suspected to be in a looped system, the two ends of the loop must be disconnected at the furthest mid-point. This disconnect should be accessible in a valve box at some point along the two-wire path, and preferably at the mid-point of the loop.

Always look at the splices first. The majority of all field problems that occur involve improper splicing. In any situation that requires troubleshooting in the field, always look at the splices of the suspected problem area first. A splice must maintain integrity between the two-wires that it is connecting. It must also be completely waterproof and must not allow any current leakage to ground.

Field problems may occur under certain conditions but not others. Try to troubleshoot under the conditions that are present during irrigation. Short Circuits or ground faults may not occur when the ground is dry, but when the ground is wet they may occur, bringing down your irrigation system.

## **TYPES OF FIELD WIRING PROBLEMS**

There are three (3) types of field wiring problems that can occur. (We are concerned here only with field wiring problems and therefore are not including problems with decoders or solenoids themselves). The three (3) types of field wiring problems are; a **wire break**, a **short circuit**, and a **ground fault**. Each presents a different problem. However, each can be

diagnosed from the central location for each problem will have different symptoms, which will be evident in the test run at the central.

## **A Break in the Two-Wire Path**

A break in the two-wire path can be indicated in two different ways in testing from the Central location. When measuring the current in the two-wire path using the Line Test Unit, the number of decoders on all of the connected two-wire paths should be indicated. If the number of decoders that is indicated is lower than the actual number of decoders in the field, then at some point on one or more of the two-wire paths the path is cut or broken and current is not reaching the decoders beyond the break. This will of course cause all of the decoders beyond the wire break not to function. To pinpoint the two-wire path having the problem, disconnect all two-wire paths, and then reconnect them one at a time. When one of them indicates a current that is less than the number of decoders that is known to be on that two-wire path, it likely has a break in the two-wire path.

Using the “Simple Decoder Test” in the Decoder Diagnostics of the central software, is another way to find the break in the two-wire path. If a number of decoders that are known to be located consecutively on a two-wire path “FAIL” the test, this is an indication that there is a break in the two-wire path on which these decoders are connected.

To pinpoint the location of the break, find the area of the two-wire path, between the *last* decoder that “PASSED” the Simple Decoder Test and the *first* decoder that “FAILED” the Simple Decoder Test. The wire break is most likely located between these two decoders on the two-wire path. Once the break has been localized, the exact break must be sought manually. This can be done by checking the voltage at any point between these two decoders. After the wire break is passed there will be a significant drop in the voltage. The voltage will not necessarily drop to zero beyond the break.

The first points to check are any splices that are in the two-wire path between the two decoders. If these do not turn up the problem, look at the middle point between the two decoders. If there is no significant voltage drop, continue on the two-wire path towards the decoder that FAILED. If there is a significant voltage drop, the problem lies toward the decoder that PASSED. Again move to the middle of the two-wire path and take a voltage measurement. Repeat this process until the break is localized. This method of searching reduces to a minimum the number of places at which measurements must be taken.

## Overloading of the Two-Wire Path, Short Circuits

If the two-wire path is damaged or a decoder develops a defect, a short circuit condition can occur to the two-wire path, resulting in nothing or only parts of the system working.

Short circuits can be diagnosed from the Central location using the Decoder Diagnostics of the software or using the Line Test Unit. By running the Current test of the Protected Line a short circuit condition can be diagnosed. When running this test at the central, the indication on the Line Test Unit should be for the number of decoders on the system when the current in the software diagnostics you should add. If the reading is much higher than this, there is a fault in the system.

If the indication is less than 400 decoders more than the actual number of decoders on the system, the problem probably lies in a defective decoder. A defective decoder may have a short in it and may be using too much power. The rest of the system will probably still work. This decoder then can be isolated by using the “Simple Decoder Test” diagnostics to pinpoint the bad decoder.

If the indication is much higher than the actual number of decoders on the two-wire path, there is a direct short circuit across the two-wire path. If there is a short circuit in a part of the two – wire path, the whole path will be affected, and the “Simple Decoder Test” can ***NOT*** be used to pinpoint this problem. At this point it is necessary to use the Clamp Meter to locate the problem.

With the Clamp Meter, the current in a wire can be measured without having to cut the wire. The clamp is opened and placed around the wire, of the cable, in which you wish to measure the current. When measuring the current on the two-wire path, the clamp must be placed around only one of the path’s two conductors that are in the cable. To use the Clamp Meter, the MDI Interface Unit must be put in the 60 Hz mode of operation, which can be done from the Decoder Diagnostics screen of the software. The current can then be measured directly by the use of the Clamp Meter by placing the meter on the mV scale.. **Using the Clamp Meter 1 mV = 1 mA.** Therefore, you can read the current in the wire directly.

If the two-wire path is shorted severely enough, the MDI Interface Unit will automatically reset itself – disconnecting the field wiring, thus shutting OFF the “Field” LED. If this is happening, the two-wire path must be placed in a 60 Hz mode to allow the line to be protected and limit current while a clamp meter is used to isolate the problem.

If the two-wire path is configured in a LOOP layout, the various LOOPS must be broken by disconnecting one end of the loop at the Line Termination Box or near the mid point of the loop.. Then by use of the Clamp Meter you can determine which of the two-wire path loops or loop

sections is using too much current. This two-wire path can then be traced to determine exactly where the short lies.

It is at this point that having a good “as-built” plan is crucial. As the Two-Wire path branches out from the central, the total draw on the entire system is the sum of the draw for each of the individual branches as you work back to the central location.

**FOR EXAMPLE:** If you have a three-way splice serving two golf holes, one of which has 20 FD-102 decoders on it, and the other, which has 10 FD-102 decoders on it – then the total draw on the “incoming” or “up-stream” wire will read 15 mA (30 x 0.5mA)

On the “outgoing” or “downstream” side of the splice, one leg should read 10mA, for the branch with the 20 decoders on it and the other branch should read 5mA, for the branch with the 10 decoders on it.

<p><b><u>NOTE !</u></b> It is this reason the Two-Wire path <b><u>MUST</u></b> be permanently Marked at each splice location as to the wire’s routing. It Can save literally hours in the field if you look at a splice And know where the wire goes !!</p>
---

Having determined which two-wire path now has the short circuit condition, by moving out onto this two-wire path, you can now determine exactly where the short circuit condition is occurring. If you measure the current ahead of the short circuit condition with the Clamp Meter it will indicate **EXCESSIVE** current due to the short circuit. However, once the short circuit is passed, the current running in the two-wire path will be quite **“LOW”**. Because there is a short circuit across the two-wire path, the current is flowing from the MDI Interface Unit out the two-wire path to the short circuit and a large portion of the excessive current is being caused and being used by the short circuit. Therefore, the two-wire path beyond the short circuit condition is not being supplied with enough current and this will be readily seen with the Clamp Meter. If the two-wire path splits into multiple branches, the branch that has the excessive current draw contains the short circuit condition.

If the short circuit condition is actually being caused by a defective decoder, it will be possible to measure current flowing into and out of that decoder, by clamping the meter around one of the blue wire from the decoder. In fact, on the “up-stream” side of the splice, where the decoder is located, you will see the excessive current and on the “downstream” side, it will be low. This can be confirmed by clamping around the blue communication wire on the suspect decoder. If the decoder is found to be defective it should be replaced.



## **Earth Ground Voltage Fault**

If one or both of the wires in the two-wire path are leaking to ground, there is an earth ground voltage fault. This indicates that somewhere on the two-wire path, current is leaking from the two-wire path to earth ground.

To protect against corrosion in the two-wire path, the average voltage in relation to the surrounding earth must be slightly **NEGATIVE**. The MDI Interface Unit determines and controls this voltage. If there is enough of a leakage to ground on the two-wire path, the average voltage to ground could become "**POSITIVE**". If the average voltage to ground should become positive, any "**NICK**" in the insulation on a wire could result in corrosion of the cable and in a short period of time the copper wire will actually disintegrate completely. Because of this dangerous corrosion of the cable, if the MDI Interface Unit senses that the average voltage to ground is "**POSITIVE**", it automatically disconnects the two-wire path from the unit to protect the cable from this condition.

The Line Test Unit can be used to measure the earth voltage, or the "Grounded Cables Test" of the Decoder Diagnostics in the system software may be used. The MDI Interface Unit should be tested first, with the two-wire paths disconnected from it. The voltage for the MDI Interface Unit alone should read between 1 volt and 4 volts when using the Line Test Unit. If it does not give this reading, then the MDI Interface Unit itself is defective and should be replaced. If you are using the "Grounded Cables Test" of the Decoder Diagnostics in the system software, then the Voltage of the MDI Interface Unit case is automatically measured. If this measurement is NOT in the acceptable range an "ERROR MESSAGE" will be displayed and the MDI Interface Unit should be replaced. If the voltage reading of the MDI Interface Unit alone is O.K. then reconnect the two-wire paths and run the Test of Earth Ground Voltage with the paths connected. This should give the same results as the test of the MDI Interface Unit alone, when using either the Line Test Unit or the software "Grounded Cables Test".

When using the Line Test Unit, if the needle moves backwards and forwards in step with the alternating of the red/green LED on the Line Test Unit, it means that there are one or more faults in the insulation of the two-wire path cable. If the needle stands below 1 volt, there is probably a ground fault in the insulation of one of the solenoids or their connecting cables.

When using the "Grounded Cables Test" of the system software, if there is a ground fault detected an "ERROR MESSAGE" will be given.

These ground faults can be found using a method similar to the short finding procedure that was discussed earlier. Using the Clamp Meter and with the system in the 60 Hz mode, each of the two wires on a given two-wire path can be measured. If one of the wires is drawing more current than the other wire, then it is a highly suspect that it may contain an earth ground fault. This can be traced down by going out to near the mid point of the two-wire path and doing a

measurement. If the two wires are both drawing the same amount of current, then you have passed the ground fault so you need to proceed with measurements on the nearest half of the two-wire path. Use the method of “halving” the distance of each segment. However, if the two wires are still one drawing more current than the other, then the ground fault is in the furthest half of the two-wire path. Move to near the half way point of this furthest half and make a measurement. If the current draw is still one greater than the other, then the ground fault is still further out – so move to the mid-point of that section and take another measurement. Continue with this procedure until the current draw in each of the wires is EQUAL. If so you have passed the ground fault location. Move to the center of the last segment and measure again – in this way you can finally accurately pinpoint the ground fault location.

# **EXAMPLES OF TYPICAL FIELD PROBLEMS THAT MAY BE ENCOUNTERED !**

## **Improper Two-Wire Cable Jacket “Stripping”(complete erosion of copper conductor):**

Improper “stripping” of the outer jacket on the Two-Wire path cable – will often result in a lengthwise cut in the inner insulation of the individual conductor. This will in time lead to the subsequent loss of the copper conductor (complete erosion of the copper). The Ultimate result would be – *loss of control of all decoders beyond this point on the two-wire path.*

This would most likely show up during the “Test for Grounded Cables”. It would also create an elevated current (mA) draw on the two-wire path, beyond what should normally be on that path, based on the number of single channel decoders (each drawing 0.5mA) and the number of multiple channel decoders (each drawing 1.0 mA) at rest. This would be visible in the two-wire path current. *You very likely would see a fluctuation in the two-wire path current draw, in the Two-Wire current “Meter” window in the decoder diagnostics screen. A healthy wire path’s current draw should remain very steady as opposed to swinging 20 to 40 or so mA’s when it is “bad”.*

This could be found with a Clamp Meter, and the system set to the 60 Hz mode. It would show up as an "inbalance" between the red and black conductors, when each is “clamped” onto individually. When you PASS the point of the damaged insulation, the readings would be EQUAL indicating the leakage to ground is between this point, that you are now at, and the point that you took the last previous reading.

If the damaged insulation happens to be in a **WET VALVE BOX**, you will *definitely* know it when you place your hand in the valve box. Sometimes this is the best way to find the damaged condition.

**NOTE !** This is one of the more common problems encountered with the field wiring – and points out the importance of taking care in “stripping” the outer jacket of the cable to avoid this happening. It can save much “down time” of the system as well as time and labor to troubleshoot the system and make the proper repairs.

**NOTE !**

***In a non-system threatening condition, a broken wire, partial short or skinned insulation as well as mildly shorted decoders will cause the “Field” LED on the MDI Interface Unit to “hesitate” or “flicker” instead of a clean “rock solid” alternationg between red and green. This is a quick visual clue that something is not right with the system.***

## **Improper Two-Wire Cable Jacket “Stripping” (corrosion of copper conductor causing leakage to ground.)**

Improper “stripping” of the outer jacket on the Two-Wire path – resulting in the inner insulation of the conductor being “nicked” and causing corrosion of the copper conductor and ultimate leakage to ground.

If the insulation on both conductors has been “nicked” – during **WET** conditions (as during an irrigation cycle) a “**SHORT CIRCUIT**” could be created causing the MDI Interface Unit to “**SHUT DOWN**” due to over current demand. This condition may be extremely difficult to find, since under a dry condition (as you would probably have when troubleshooting during the non-irrigation hours) this short circuit would not occur. Thus if the condition continues to exist it will require troubleshooting when the soil is wet in order to find the trouble spot. You can use the “**Grounded Cables Test**” and the outlined procedure as given in the “**EARTH GROUND VOLTAGE FAULT**”, previously presented. You will also likely see the fluctuation in the two-wire path current draw as outlined in the previous section.

If just one of the conductors has its insulation “nicked”, then this fault could be found using a Clamp Meter and having the system in the 60 Hz mode. Under this condition there would be an “inbalance” between the two conductors, with the damaged conductor drawing the most current. Once you **PASS** the damaged area on the two-wire path, the two conductors would then have an **EQUAL** current draw. Thus you know that the “nicked” conductor is between the point where you now are and the last previous point that you took a reading. Remember nicked insulation can occur on the blue communication wires from the decoders themselves.

If one of the conductors have completely eroded away, this will be indicated with loss of communication and operation of decoders beyond the point of the loss of the conductor copper. Follow the procedure outlined in the previous “**IMPROPER TWO-WIRE CABLE JACKET “STRIPPING” (complete erosion of copper conductor).**

## Shorted “MSP-1” Surge Arrestor:

The **SYMPTOM** is that the MDI Interface Unit “disconnects” or “shuts down” due to over draw of

current due to dead short of MSP-1 surge arrestor.

**Troubleshooting approach:** With the Line Test Unit – Set the “METER” to #3 and the “LINE” to #2 – this will provide the “protected line” by limiting the current draw and thus keeping the MDI Interface Unit operating so that the short can be located. System must be in the 60 Hz mode of operation. By using the Clamp Meter measure the current. Check the Black and Red wires on the “EQUIPMENT” or “Up-stream” side of the MSP-1. It will read **HIGH**, Then check the “FIELD” or “Down-stream” side of the MSP-1. If the reading is **LOW**, the *MSP-1 is shorted* and needs to be replaced.

An LSP-1 Surge Arrestor can be checked for a shorted condition by clamping the Clampmeter around one of the blue communication wires.

## Simulated “Shorted” Solenoid

If a Valve-in-Head sprinkler or a remote control valve is **NOT** Operating, but the Decoder

controlling it seems to be functioning O.K. and passes all decoder diagnostic tests and provides proper feedback and logging, it would then lead you to checking the solenoid coil. If it checks at *10 Ohms or less* then the solenoid needs to be replaced as it is acting as a “shorted” solenoid.

## Partial Failure of FD-601 Decoder:

One or Two of the Outputs of an

FD-610/FD-601 Decoder is NOT operating. All the other outputs are working O.K. In checking the current draw of the decoder at rest you get a low current reading (in the range of

0.6mA or less when it should be 1.0 mA) it is indication that one or more of the outputs are not operating.

This is NOT a system threatening situation. If there are any of the six outputs not being used it can be switched over to take the place of the output that is not working. If there are no unused outputs then a single FD-210/FD-102 decoder can be wired in to take the place of the outputs that are not working. If there are more than two outputs not working, then it would be more cost effective to replace the FD-610/FD-601 decoder with a new one.

## Decoder Simply Does Not Operate:

Valve-in-Head sprinkler or

Remote Control Valve will work manually but will not operate from the decoder. Solenoid has been tested and tests O.K.

This decoder would most likely turn up in a “NO-FEEDBACK” yellow portion of the “FLOWBAR”. It would have “incorrect” logging and/or fail the decoder diagnostics test. Replace with a new decoder.

## Decoder Remains in the “ON” Condition at all Times:

In the 60 Hz mode of operation, with a Clamp Meter clamped around one of the blue wires of the decoder - this decoder shows a current draw much in excess of the normal 0.5 mA draw at rest (perhaps as high as 23 mA or greater). The solenoid connected to it is “stuck on”. Connecting another solenoid to this decoder it also is activated continuously. This decoder will also “FAIL” all decoder diagnostic tests. Replace with a new decoder.

## Decoder Drawing Extremely Excessive Current:

Symptom: MDI Interface Unit “shut down” due to excessive current draw.

If this is a big system with a large number of decoders or a system with a number of other additional damage, it can quickly overdraw the current capability of the MDI Interface Unit and therefore will disconnect itself from the field shutting the system “down”. The system must be placed in the “protected line” mode and the 60 Hz mode in order to keep the MDI Interface unit in operation and then by use of a Clamp Meter troubleshooting of the system can take place. By using the Clamp Meter measure the current, of one of the conductors, in the two-wire path. As you move out onto the two-wire path ahead of the faulty decoder, the clamp meter will indicate an “EXCESSIVE” current due to the shorting of the decoder. Once you **PASS** this shorting decoder however, the current in the two-wire path will be quite “LOW”. Thus you have narrowed the area in which the faulty decoder is located. You should have gotten some indication of the possible decoder location from the Decoder Diagnostics Tests also. The decoder itself can be checked by using the Clamp Meter and measuring the current in one of the “WHITE” wires from the decoder and connecting to the two-wire path. The faulty decoder will be drawing an excessive amount of current (perhaps in the 600 mA or greater range). It is also possible that there are more than one decoder on the system that is overdrawing current.

## Lightning Damaged Solenoid and/or Decoder:

Decoder shows a failure in the “Decoder Diagnostics Test” since it would be unable to complete the circuit. If only the Decoder were changed and the test run again it may still “FAIL” indicating that the solenoid was bad. Therefore, when you are checking the decoder also check the solenoid using a volt-ohm meter.. If it shows an “OPEN” condition it has been damaged from surge and needs to be changed. Just changing the solenoid however, may not correct the condition. Damage, to this degree, of the solenoid would almost undoubtedly take out the decoder also and in most cases it would also need to be changed.

In damage that can be attributed to lightning, it is good practice to simply change out the solenoid when the decoder is being changed – since in most cases both will be damaged.

## TROUBLESHOOTING IS AN ART:

Troubleshooting is some what of an art, but tracking down a problem in a decoder system is elementary if logical troubleshooting procedures are followed. The preceding does not give all the possibilities one might encounter in the field, but will serve to provide you with the proper tests to follow in identifying the type of problem you have and presents the proper procedures to use in “pin pointing” the exact location of the problem area.

Before you go to the field, first layout your plan of attack and method of procedure according to the type of problem you have identified. By doing this first and then going into the field you can save a lot of time in actually locating the problem area and making the required repairs.

## **CLAMP METER SPECIFICATIONS:**

The Clamp Meter is required for a large portion of the troubleshooting procedures given for the following suspected field failure conditions and tests.

The Clamp Meter **MUST** meet or exceed the following **SPECIFICATIONS**, which are based on AEMC Instruments' AC Current Probe – Model MN103:

### **ELECTRICAL SPECIFICATIONS:**

#### ***Current Range (LOW):***

**10A: 1 mA to 10 Amp AC**

#### ***Output Signal:***

**1 mV AC/mA AC (10V @ 10A)**

#### ***Accuracy and Phase Shift:***

**Accuracy: 1 mA to 10 Amp AC**

**45 to 65 Hz  $\pm$  3% of reading  $\pm$  1 mA**

**45 to 500 Hz : -2, +6% of reading  $\pm$  1 mA**

#### ***Current Range (HIGH):***

**100A: 1 A to 100 Amp AC**

#### ***Output Signal:***

**1 mV AC/A AC (100mV @ 100A)**

#### ***Accuracy and Phase Shift:***

**Accuracy: 1 A to 100 Amp AC**

**45 to 65 Hz  $\pm$  2% of reading  $\pm$  0.1 A**

**45 to 500 Hz : -2, +3% of reading  $\pm$  0.1 A**

***Frequency Range: 45 to 1000 Hz***

***Load Impedance: 10 k $\Omega$  min.***

***Working Voltage: 600 Volts AC***

***Common Mode Voltage: 600 Volts AC***

***Maximum Conductor Size: 0.47"  $\varnothing$  Max. (12 mm)***

**NOTE !** *This meter **MUST** be used in conjunction with a Voltmeter – as the output of the Clampmeter is in mV's, and is read on the mV scale of a Voltmeter.*

One type of Clampmeter that is commonly used is one manufactured by EXTECH - Model 380943. It will clamp an electrical wire up to 1.2" in diameter, to measure AC current from 0.01mA to 100A. It stores both maximum and minimum values and has data hold function. It will test AC volts up to 400 volts, resistance to 400 $\Omega$  and has audible continuity indicator.

# ADDENDUM

## **SPECIFICATIONS for MAXI COMMUNICATION WIRE**

(This Specification shall take precedence over all previous Specifications for MAXI Communication Two-Wire Paths and is dated MARCH 20, 1992.)

The MAXI Type Communication wire for the Two-Wire paths shall be double jacketed, two conductor cable intended for control of the Communications Signal and Feed-back Signal for the Rain Bird Central Computerized Control Systems. The cable shall be suitable for direct burial in the earth and also may be installed in ducts or conduits.

### **Conductors:**

The Conductors shall be tin coated (for good mechanical bonding), soft drawn, annealed solid copper conforming to the requirements of ASTM-33. Each conductor shall be insulated with 4/64" (minimum) thick PVC conforming to the requirements of U.L. Standard #493 for thermoplastic insulated underground feeder cables (TYPE UF).

The two (2) conductors shall be color coded with one conductor **BLACK** and the other **RED**. Both conductors shall be of the same size and shall be of sizes as specified and/or shown on the drawings and a required for the proper operation of the Satellite and Decoder units connected to it.

The wire manufacturer (not the wire broker) shall certify in writing, for each shipment, that the insulated conductors have been tested for and meet the requirements of U.L. Standard #493 for thermoplastic-insulated, underground feeder cables (TYPE UF). He shall also certify in writing that the individual conductors have a minimum insulation thickness of 4/64" throughout the entire length of the cable and that the finished caable meets the following requirements of the same standard:

**Dielectric Boltage**  
**Withstand Test . . . . . 5000V for 60 Seconds**

**Tension and Elongation**

Test . . . . .	300 lbf, no separation
Impact Test . . . . .	6000V after the impact
Crushing Resistance Test . . . . .	an average of no less than 4500 lbf flat An average of no less than 1200 lbf edge
Cold Bend Test . . . . .	No Cracks
Water Absorption	

In addition each shipment of cable shall include a current dated listing card from the Underwriters, showing the MANUFACTURER'S U.L. IDENTIFICATION NUMBER - as evidence that the MANUFACTURER is approved to manufacture thermoplastic insulated underground feeder cable in accordance with the U.L. Standard #493.

**Outer Jacket:**

The two (2) conductors shall be laid parallel and covered with a Solid Color, HIGH DENSITY, sunlight resistant polyethylene outer jacket, of the color coding specified and conforming of the requirements of ICEA S-61-402 and NEMA WC 5. The MINIMUM jacket thickness, when measured at any point in contact with the PVC insulation of the copper conductor and to the outer surface of the outer jacket, shall be 3/64" thick. The outer jacket shall be PRESSURE EXTRUDED so as to COMPLETELY FILL the interstices between the two insulated wires.

The polyethylene outer jacket shall conform to the following

***ELECTRICAL PROPERTIES***

<u>PROPERTY</u>	<u>NOMINAL VALUE</u>	<u>UNITS</u>	<u>ASTM TEST MTD</u>
Dielectric Constant @ 100 KHz	2.28		D 1531
Dissipation Factor @ 100 KHz	0.00008		
Volume Resistivity, Original	1 x 10 <sup>18</sup>	OHM-CM	D 991

## **TYPICAL PHYSICAL PROPERTIES**

<b><u>NOMINAL PROPERTY</u></b>	<b><u>VALUE</u></b>	<b><u>ASTM UNITS</u></b>	<b><u>TEST MTD</u></b>
Density	0.917	g/cu cm	D 1505
Melt Index	0.25	g/10 min	D 1238
Low Temperature Brittleness F60	-76	°C	D 746
Hardness, Shore D	43 or greater		D 1047
Tensile Strength	2040	PSI	D 638
Elongation	570	%	D 638
Environmental Stress Crach Resistance 10% lgal	0 Failures @ 7 days		D 1693

The entire outer polyethelene jacket shall be of the color specified for easy identification of the Two-Wire path. Each Two-Wire Path on the system shall have a different color outer jacket for easy identification after installation and for easily distinguishing between the various Two-Wire paths on the system. Standard colors for the outer jacket color coding shall be - White, Red, Green, Blue, Yellow, Orange and Black.

The MAXI® Type Cable SHALL be marked on the jacket as follows - **MAXI TYPE COMMUNICATION CABLE - 2/C ## AWG**, along with the manufacturer's name and identification number (which is mandatory) and other designations, such as, voltage rating, etc., as may be appropriate. The wire **SHALL NOT** be marked with the name **RAIN BIRD** or any other similar designation, except as noted above.

The manufaacturer shall also ceertify in writing that the POLYETHELENE outer jacket is of minimum thickness (3/64") throughout the entire length of the cable and that it does neet and conform to the requirements of ICEA S – 61 – 402 and NEMA WC 5 as outlined above for both Electrical Properties and Physical Properties.

The cable shall be shipped on non-returnable wood reels, in the lengths and color coding outer jacket color as specified.

The MAXI Type Communication Cable, for the Two-Wire Paths of the various Rain Bird control systems shall meet or exceed the above specifications in all respects and ALL written certifications from thje MANUFACTURER shall be supplied with the wire as outlined and called for in these specificalitons.

# INSTALLATION DETAILS FOR MDI INTERFACE UNIT AND LINE TERMINATION BOX (LTB).

## Wiring of SUP-210 Surge Arrestor at MDI Interface Unit:

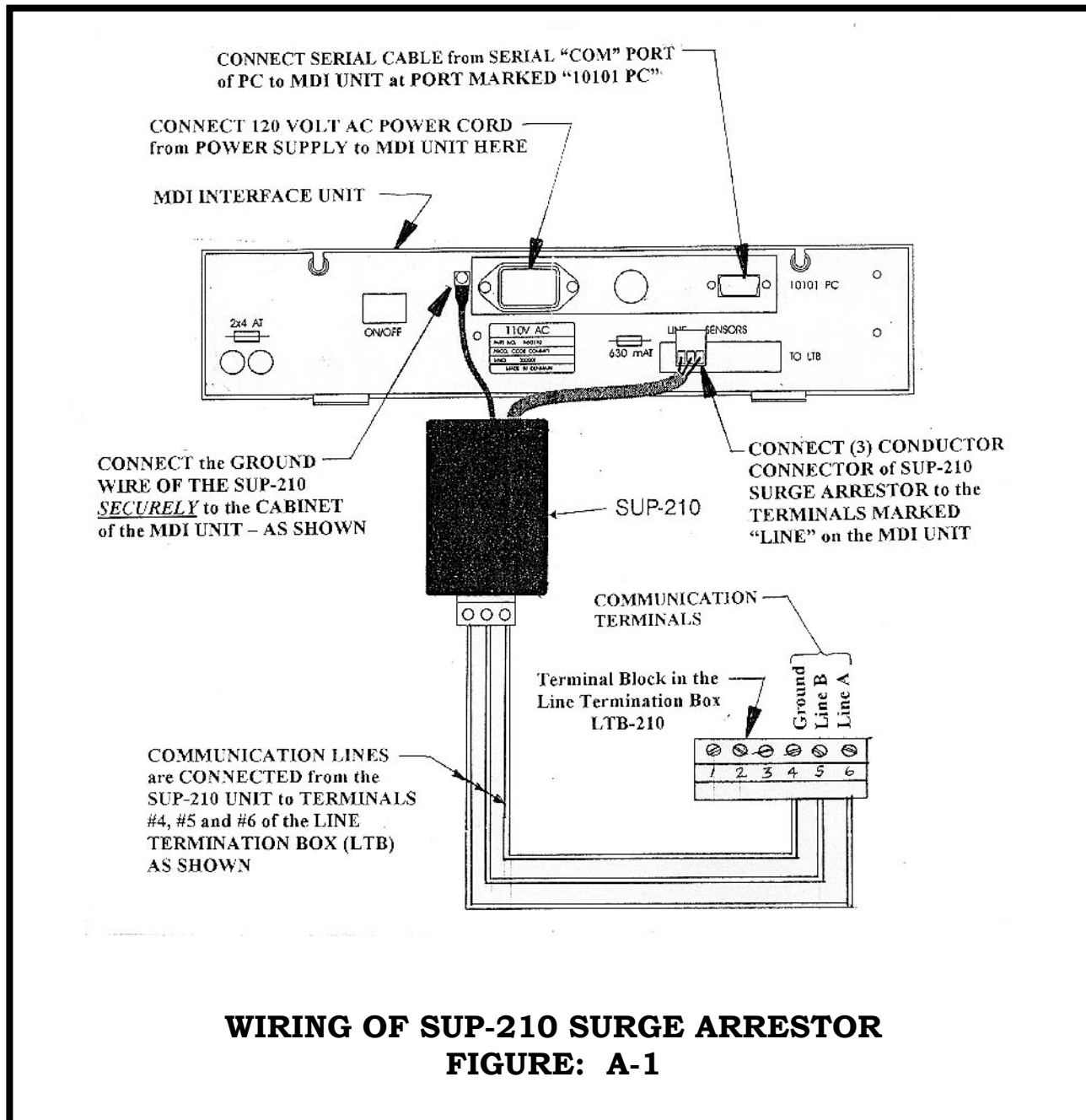

**Communication and Sensor Wiring Between  
DI Interface unit and Line Termination Box (LTB-210):**

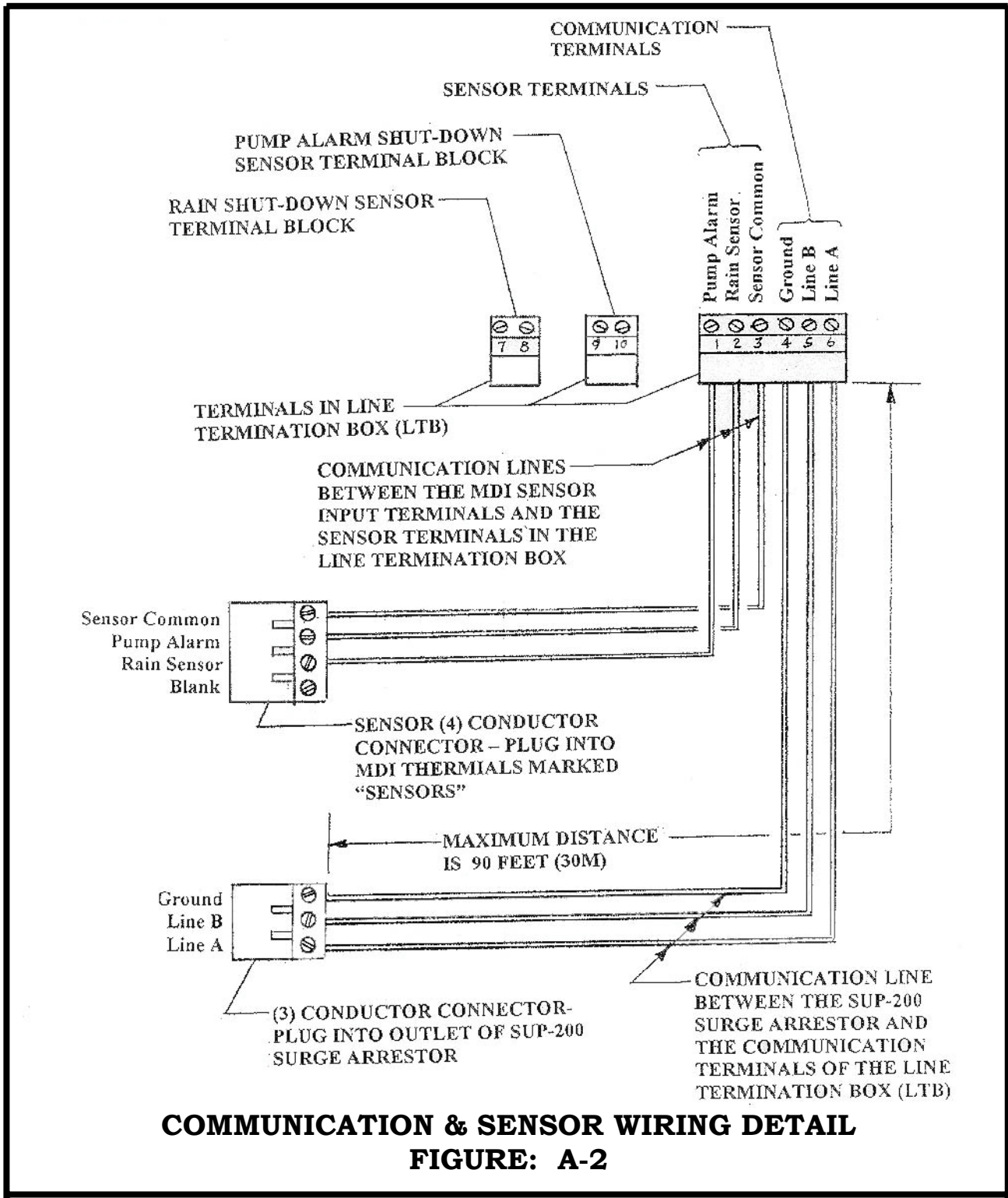

**COMMUNICATION & SENSOR WIRING DETAIL  
FIGURE: A-2**

# Wiring Detail at the Line Termination Box (LTB-210):

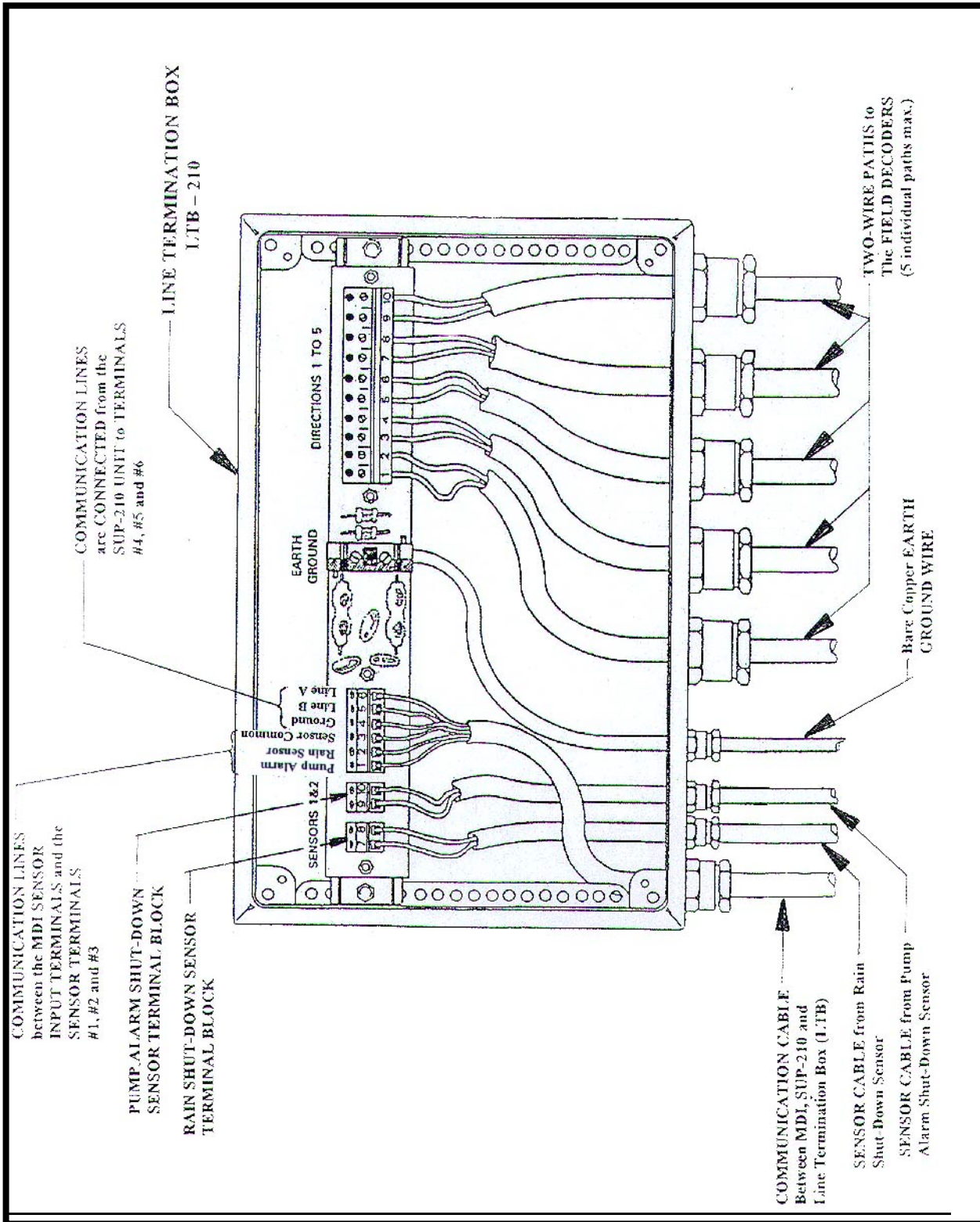

# LDI Installation details

Figure 2002

(Large Decoder Interface)

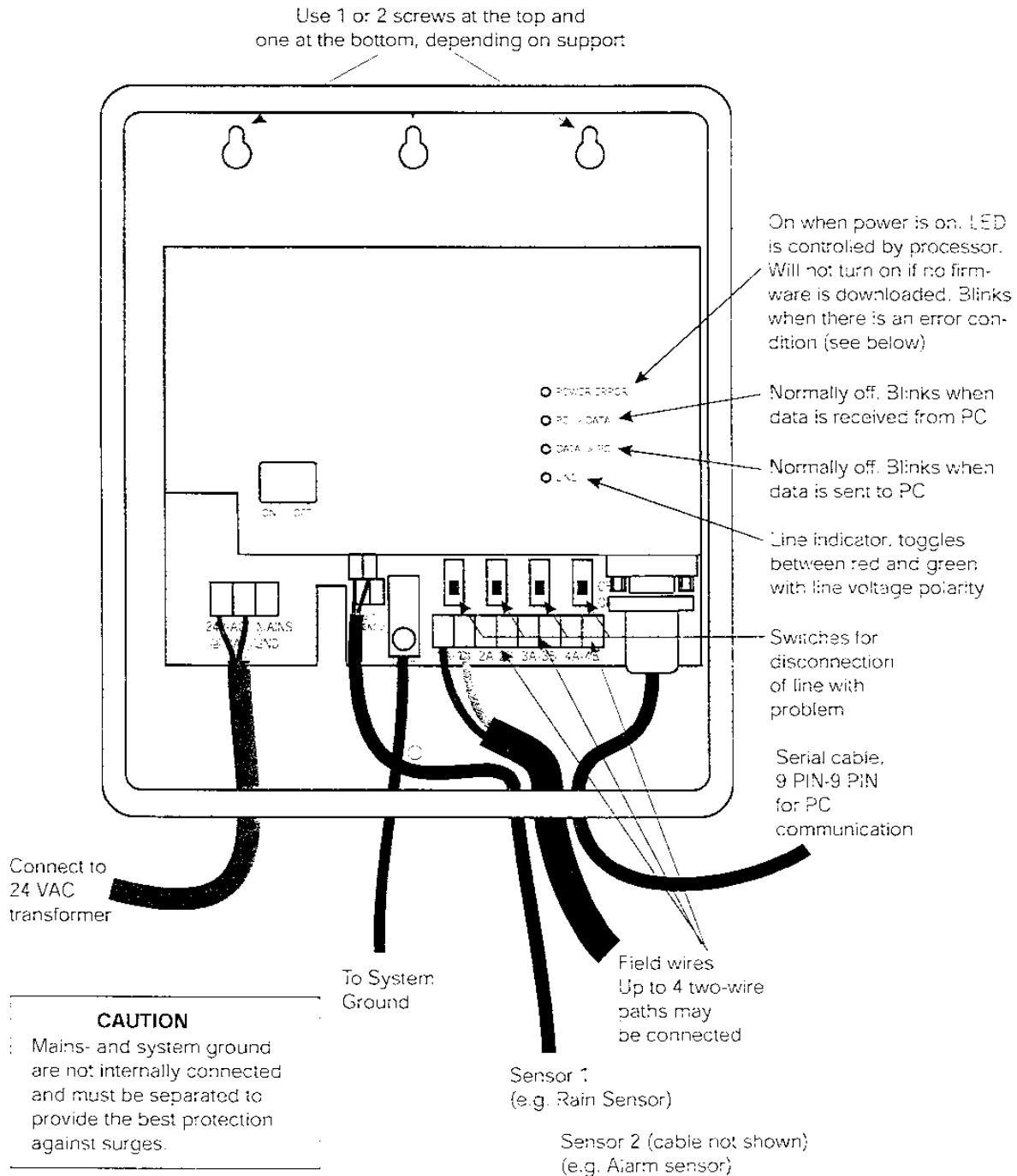

During power up the LED's will blink in sequence ending with POWER LED on for 5 seconds. During those 5 seconds the Flash boot program may be activated for download of new firmware (see special instruction).

If the POWER LED blinks it means that an error is detected by the unit. The reason for the error is indicated by the other LED's:

- If 'DATA->PC' is on it means that line voltage has been switched off because connection to the PC is lost.
- If 'LINE' is on it means that line voltage is below 25 V (short).

# SDI

## Installation details

176-123-0009

(Small Decoder interface)

Use 1 or 2 screws at the top and one at the bottom, depending on support

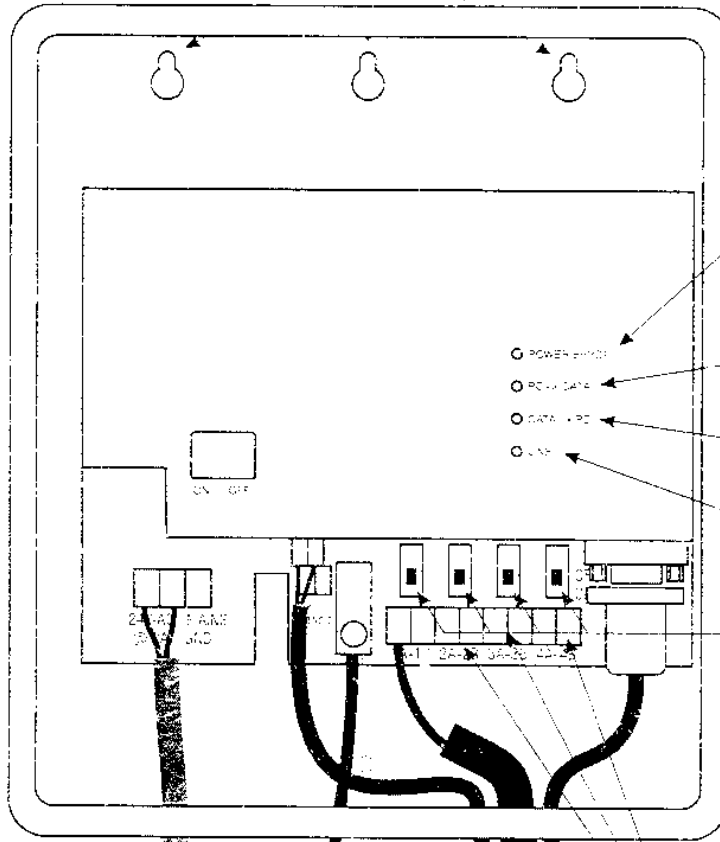

On when power is on. LED is controlled by processor. Will not turn on if no firmware is downloaded. Blinks when there is an error condition (see below)

Normally off. Blinks when data is received from PC

Normally off. Blinks when data is sent to PC

Line indicator, toggles between red and green with the voltage polarity

Switches for disconnection of line with problem

Serial cable, 9 PIN, 9 PIN for PC communication

Connect to 24 VAC transformer

To System Ground

Field wires  
Up to 4 two-wire paths may be connected

Sensor 1  
(e.g. Rain Sensor)

Sensor 2 (cable not shown)  
(e.g. Alarm sensor)

### CAUTION

Mains- and system ground are not internally connected and must be separated to provide the best protection against surges.

During power up the LED's will blink in sequence ending with POWER LED on for 5 seconds. During those 5 seconds the Flash boot program may be activated for download of new firmware (see special instruction).

If the POWER LED blinks it means that an error is detected by the unit. The reason for the error is indicated by the other LED's:

-If "DATA->PC" is on it means that line voltage has been switched off because connection to the PC is lost.

-If "LINE" is on it means that line voltage is below 25 V (short).

Drawing No. 176-123-0009/A