

UNI-Spray™ Series

The Universal Spray Head

Primary Application

The UNI-Spray™ is designed for those applications where flexibility and convenience are primary considerations. These reliable, compact spray heads are shipped with or without pre-installed Variable Arc Nozzles (VANs) that are adjustable from 0° to full circle operation, saving hours of installation time, effort and money.

Features

- Pressure-activated, wiper seal prevents excessive flow-by and water waste. Keeps debris from entering upon retraction.
- Durable stem ratchet allows for quick and easy nozzle pattern alignment.
- Internal parts removable from the top of the sprinkler for easy servicing.
- Small exposed cover makes the unit virtually invisible for more attractive landscapes.
- Rugged cover and body provide durability in high pressure and surge conditions.
- Plastic and stainless steel materials resist corrosion.
- VAN nozzle and screen are easily removable for flushing.
- UNI-Spray™ accepts all Rain Bird® Series nozzles and accessories, which simplifies inventory management.
- Optional field installable Seal-A-Matic™ check valve prevents low head drainage up to five feet (1,5 m) of elevation difference.
- Three-year trade warranty.

Operating Range

- Spacing: 10 VAN Series: 8 to 10 feet (2,4 to 3,0 m)
- 12 VAN Series: 10 to 12 feet (3,0 to 3,7 m)
- 15 VAN Series: 12 to 15 feet (3,7 to 4,6 m)
- 18 VAN Series: 14 to 18 feet (4,3 to 5,5 m)
- Pressure: 15 to 70 psi (1,0 to 4,8 bar)
- Optimum Pressure: 30 psi (2 bar)
- Adjustable nozzle arc range: 0°-360°

Specifications

- Flow-by: 0 at 10 psi (0,75 bar) or greater; 0.50 Gpm (0,11 m³/h; 0,03 l/s) otherwise

Dimensions

- ½" (15/21) NPT female threaded inlet
- Body height:
- US-200: 3¾" (9,6 cm)
- US-400: 5⅞" (15 cm)
- Exposed surface diameter: 1¼" (3,2 cm)

Models*

- US-400: 4" pop-up height (10,3 cm)
- US-410 VAN: 4" pop-up height (10,3 cm) with 10-VAN attached
- US-212 VAN: 2" pop-up height (5,1 cm) with 12-VAN attached
- US-412 VAN: 4" pop-up height (10,3 cm) with 12-VAN attached
- US-215 VAN: 2" pop-up height (5,1 cm) with 15-VAN attached
- US-415 VAN: 4" pop-up height (10,3 cm) with 15-VAN attached
- US-418 VAN: 4" pop-up height (10,3 cm) with 18-VAN attached
- US-SAM: UNI-Spray™ check valve

*The UNI-Spray™ sprinkler body accepts all Rain Bird nozzles.

For performance data of other Rain Bird nozzles, see the Landscape Irrigation Products Catalog-Sprays Section.



How To Specify

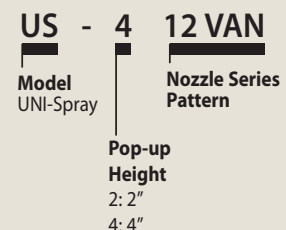

This specifies a UNI-Spray body with a 4" (10,3 cm) pop-up height; 12 foot (3,6 m) variable arc nozzle (VAN)

UNI-Spray™ Series Performance Tables

10 Series VAN					
10° Trajectory					
Nozzle	Pressure psi	Radius ft.	Flow gpm	Precip In/h	Precip In/h
360° Arc	15	7	1.93	3.80	4.39
	20	8	2.32	3.50	4.04
	25	9	2.52	3.00	3.46
	30	10	2.60	2.50	2.89
270° Arc	15	7	1.45	3.80	4.39
	20	8	1.75	3.50	4.04
	25	9	1.89	3.00	3.46
180° Arc	15	7	0.97	3.80	4.39
	20	8	1.20	3.50	4.04
	25	9	1.26	3.00	3.46
90° Arc	15	7	0.48	3.80	4.39
	20	8	0.58	3.50	4.04
	30	9	0.63	3.00	3.46

10 Series VAN					
METRIC					
10° Trajectory					
Nozzle	Pressure bar	Radius m	Flow m ³ /h	Flow l/m	Precip mm/h
360° Arc	1.0	2.1	0.44	7.3	96
	1.5	2.4	0.53	9.0	89
	2.0	2.7	0.57	9.8	76
	2.1	3.1	0.59	9.8	63
270° Arc	1.0	2.1	0.33	5.5	96
	1.5	2.4	0.4	6.8	89
	2.0	2.7	0.43	7.8	76
180° Arc	1.0	2.1	0.22	3.7	96
	1.5	2.4	0.27	4.6	89
	2.0	2.7	0.29	5.3	76
90° Arc	1.0	2.1	0.11	1.8	96
	1.5	2.4	0.13	2.3	89
	2.0	2.7	0.14	2.7	76

15 Series VAN					
23° Trajectory					
Nozzle	Pressure psi	Radius ft.	Flow gpm	Precip In/h	Precip In/h
360° Arc	15	11	2.60	2.07	2.39
	20	12	3.00	2.01	2.32
	25	14	3.30	1.62	1.87
	30	15	3.70	1.58	1.83
270° Arc	15	11	1.95	2.07	2.39
	20	12	2.25	2.01	2.32
	25	14	2.48	1.62	1.87
180° Arc	15	11	1.30	2.07	2.39
	20	12	1.50	2.01	2.32
	25	14	1.65	1.62	1.87
90° Arc	15	11	0.65	2.07	2.39
	20	12	0.75	2.01	2.32
	25	14	0.82	1.62	1.87

15 Series VAN					
METRIC					
23° Trajectory					
Nozzle	Pressure bar	Radius m	Flow m ³ /h	Flow l/m	Precip mm/h
360° Arc	1.0	3.4	0.60	9.8	52
	1.5	3.9	0.72	11.8	47
	2.0	4.5	0.84	13.7	41
	2.1	4.6	0.84	14.0	40
270° Arc	1.0	3.4	0.45	7.4	52
	1.5	3.9	0.54	8.8	47
	2.0	4.5	0.63	10.3	41
180° Arc	1.0	3.4	0.30	4.9	52
	1.5	3.9	0.36	5.9	47
	2.0	4.5	0.42	6.9	41
90° Arc	1.0	3.4	0.15	2.5	52
	1.5	3.9	0.18	2.9	47
	2.0	4.5	0.21	3.4	41

12 Series VAN					
15° Trajectory					
Nozzle	Pressure psi	Radius ft.	Flow gpm	Precip In/h	Precip In/h
360° Arc	15	9	1.56	1.86	2.14
	20	10	1.86	1.79	2.06
	25	11	2.12	1.68	1.95
	30	12	2.36	1.58	1.82
270° Arc	15	9	1.17	1.86	2.14
	20	10	1.39	1.79	2.06
	25	11	1.59	1.68	1.94
180° Arc	15	9	0.78	1.86	2.14
	20	10	0.93	1.79	2.06
	25	11	1.06	1.68	1.95
90° Arc	15	9	0.39	1.86	2.14
	20	10	0.46	1.79	2.06
	25	11	0.53	1.68	1.95

12 Series VAN					
METRIC					
15° Trajectory					
Nozzle	Pressure bar	Radius m	Flow m ³ /h	Flow l/m	Precip mm/h
360° Arc	1.0	2.7	0.35	5.80	48
	1.5	3.2	0.44	7.37	43
	2.0	3.6	0.52	8.75	41
	2.1	3.7	0.54	9.02	40
270° Arc	1.0	2.7	0.26	4.35	48
	1.5	3.2	0.33	5.53	43
	2.0	3.6	0.39	6.56	41
180° Arc	1.0	2.7	0.17	2.90	48
	1.5	3.2	0.22	3.69	43
	2.0	3.6	0.26	4.37	41
90° Arc	1.0	2.7	0.09	1.45	48
	1.5	3.2	0.11	1.84	43
	2.0	3.6	0.13	2.19	41

18 Series VAN					
26° Trajectory					
Nozzle	Pressure psi	Radius ft.	Flow gpm	Precip In/h	Precip In/h
360° Arc	15	14	4.21	2.07	2.39
	20	15	4.70	2.01	2.32
	25	17	4.86	1.62	1.87
	30	18	5.32	1.58	1.83
270° Arc	15	14	3.16	2.07	2.39
	20	15	3.52	2.01	2.32
	25	17	3.65	1.62	1.87
180° Arc	15	14	2.11	2.07	2.39
	20	15	2.35	2.01	2.32
	25	17	2.43	1.62	1.87
90° Arc	15	14	1.05	2.07	2.39
	20	15	1.17	2.01	2.32
	25	17	1.22	1.62	1.87

18 Series VAN					
METRIC					
26° Trajectory					
Nozzle	Pressure bar	Radius m	Flow m ³ /h	Flow l/m	Precip mm/h
360° Arc	1.0	4.3	0.96	15.9	52
	1.5	4.8	1.07	18.0	47
	2.0	5.4	1.20	19.8	41
	2.1	5.5	1.21	20.1	40
270° Arc	1.0	4.3	0.72	12.0	52
	1.5	4.8	0.80	13.5	47
	2.0	5.4	0.90	14.8	41
180° Arc	1.0	4.3	0.48	8.0	52
	1.5	4.8	0.54	9.0	47
	2.0	5.4	0.60	9.9	41
90° Arc	1.0	4.3	0.24	4.0	52
	1.5	4.8	0.27	4.5	47
	2.0	5.4	0.30	5.0	41

Note: Turning the radius reduction screw may be required to achieve catalog radius and flow when the arc is set at less than maximum arc

- Square spacing based on 50% diameter of throw
- ▲ Triangular spacing based on 50% diameter of throw

Performance data taken in zero wind conditions

Performance Installation Method

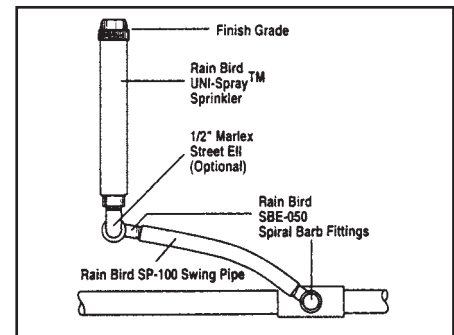

Turning the radius reduction screw may be required to achieve catalog radius and flow when the arc is set at less than full circle.

Rain Bird Corporation
6991 E. Southpoint Road
Tucson, AZ 85756
Phone: (520) 741-6100
Fax: (520) 741-6522

Rain Bird Corporation
970 West Sierra Madre Avenue
Azusa, CA 91702
Phone: (626) 812-3400
Fax: (626) 812-3411

Rain Bird International, Inc.
1000 West Sierra Madre Ave.
Azusa, CA 91702
Phone: (626) 963-9311
Fax: (626) 852-7343

Rain Bird Technical Services
(800) RAINBIRD (1-800-724-6247)
(U.S. and Canada)

Specification Hotline
800-458-3005 (U.S. and Canada)

The Intelligent Use of Water™
www.rainbird.com