

Maintenance Guide

Impact Sprinklers

Impact Sprinkler Head Types: Spoon-Driven, Wedge-Driven, and Precision Jet (PJ™).

Principal of operation:

On spoon-driven sprinklers, the water passes through the body (1), then through the nozzle (2), past the sloping vane (3), through the window (4) into the curve of the spoon (5). The reactionary force of the water leaving the spoon drives the arm out of the stream and away from the nozzle. The tension of the arm spring (6) then pulls the arm back into the original position where it impacts on the bridge or nozzle, causing the sprinkler to turn. The impact is accentuated by the thickness and angle of the leading edge of the sloping vane.

How Impact Sprinklers Operate

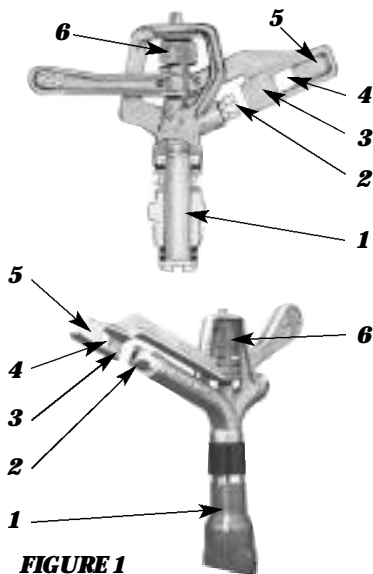

FIGURE 1

This impact is only sufficient to cause a small degree of travel so that the rotation of sprinkler is uniform and relatively slow (one-half to three minutes per revolution, depending on pressure and size of sprinkler and nozzle). Slow rotation keeps wear on moving parts at a minimum and prolongs the life of the sprinkler.



Wedge-drive sprinklers (such as the Rain Bird 14V) operate in the same manner except that the wedge rather than a spoon serves to force the arm in or out of the water stream. The chief advantages of the wedge are that it prevents an excessive amount of water from being deposited just below the sprinkler, and that it provides a greater driving force that rotates these sprinklers satisfactorily with smaller size nozzles.

Rain Bird patented Precision Jet (PJ™) sprinklers operate in a manner similar to a spoon-drive sprinkler with the PJ tube replacing the spoon. When the arm enters the stream, the water is directed through a tube. The back force of the water exiting the tube is along a line away from the fulcrum and, therefore, the arm is kicked back out of the stream. The advantage of the precision jet sprinkler is that side splash is eliminated. The PJ feature is used on part circle sprinklers that are placed adjacent to areas not to be watered.

Cause of Sprinkler Failure or Faulty Operation.

Through many years of experience, we have found the conditions which interfere with the proper operation of Rain Bird sprinklers. The following

items outline these conditions in detail and provide the necessary steps to resume proper sprinkler operation.

1 Foreign Objects in Irrigation Water

If the sprinkler does not contain a stream straightener (small vaned device inside sprinkler in the nozzle, or just behind nozzle), soft materials may be removed from obstructed nozzles by inserting a coated or covered piece of wire, such as a pipe cleaner, through the nozzle while the sprinkler is operating. Care should be taken to avoid scratching the nozzle opening. If this fails, the nozzle should be removed and cleaned. Sprinklers containing stream straighteners should not be cleaned with a wire because of the possibility of damaging the vanes on the straightener. It is recommended that the nozzle and straightener be removed and cleaned.

The best guarantee against nozzle plugging problems is to adequately screen the water where it enters the system. Where water is derived from irrigation ditches, screening at the intake is a necessity. Information on types of screening/filtering devices may be obtained from your Rain Bird distributor.

2 Oil or Pipe Dope

Rain Bird sprinklers are WATER LUBRICATED and must NOT be oiled in any manner. Oil causes the bearing washer to swell and soften and affects the rotation of the sprinkler, frequently bringing it to a complete stop. Pipe dope or thread lubricant contains oil, and when applied to the bearing threads is carried to the washer, saturating it and causing the sprinkler to stop turning. If oil has been applied to the sprinkler, it will be necessary to disassemble the bearing and wipe the oil off the sleeve and nipple and replace the washer(s) with a new, clean one.

Bearing washers are composed of material which provides the friction necessary for the successful operation of the sprinkler. As stated previously, Rain Bird sprinklers are WATER LUBRICATED and all materials used in their construction are anti-rust and anti-friction metals, except the bearing washer.

3 Improper Pressure

Rain Bird sprinklers are designed and adjusted to operate over fairly wide pressure ranges depending on the model. When operating on pressure that is either too high or too low, the performance will be unsatisfactory both as to sprinkler rotation and water distribution. Operating a nozzle at too low of a pressure will result in large droplets and a distribution of most of the water around the outer edge of the pattern. If the pressure is extremely low the sprinkler may fail to rotate. In the case of too high a pressure, the nozzle will tend toward misting and even slight wind currents will carry the water away from the desired pattern. Extremely high pressure could cause the sprinkler arm to strike the back of the sprinkler body, causing the sprinkler to stand still or turn backwards. In general, as nozzle size increases, so must the pressure for desired performance.

4 Measuring Water Pressure

The nozzle pressure of a sprinkler is measured with a pilot tube while the sprinkler is in operation.



FIGURE 2
Pitot Tube - 41017
and Gauge - RBGL 100



FIGURE 3
Pitot tube shown properly
inserted into sprinkler nozzle.
(Approx. 1/8" out from nozzle opening)

The pitot tube is used with a pressure gauge as shown in Figure 2. When used to measure the operating pressure of a sprinkler, where more than one sprinkler is operating on one pipe line or lateral, the curved end of the tube is inserted into the nozzle.

When measuring the operating pressure of a single sprinkler, on a pipe line or hose, such as a lawn or garden sprinkler, the curve end of the tube must be held approximately 1/8" out from the nozzle opening and in the center of the stream. This is done so that the flow of water from the individual sprinkler will not be retarded, thus building up the pressure.

Move the curve end of the tube back and forth through the stream until the highest pressure is recorded.

All pressures indicated in this manual and our catalog are pressures at the sprinkler, which may differ considerably from pressures at a distant source from which water is supplied. Small diameter pipe or hose will reduce pressure considerably. Failure of a sprinkler to perform properly when pressure is lower than recommended for a particular size nozzle may be overcome by changing to a smaller size nozzle. However, it is not advisable to use a nozzle smaller than the minimum recommended size for the particular sprinkler model. To illustrate, sprinkler Model No. 30W failing to operate properly with a 3/16" nozzle may give very satisfactory performance with a 9/64" nozzle.

On the ADJ models, an adjustable pin is used on the nozzle extension- see Figure 4. At pressures from 30 pounds up, the pin should not be set into the stream as far as when the sprinkler is operating at lower pressures (20 to 30 pounds). For these low pressures, you can adjust the pin so as to secure the desired break-up of the stream. This pin also can be adjusted to shorten the throw of the stream, where it is desirable to use the sprinkler in a smaller area.

The DC nozzle is used for controlling distance of throw. It is operated by adjusting the deflector downward into the water stream to decrease the distance of throw as desired.

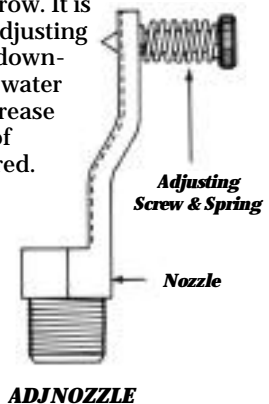

ADJ NOZZLE



DC NOZZLE

FIGURE 4

5 Damaged Parts

Occasionally sprinkler parts may be bent by accident. Cast bronze and aluminum alloy, used in Rain Bird parts, are pliable to certain limits. These parts can usually be bent back into shape if they are not too badly damaged.

In the case of bending of a model 20 or 25 arm into shape after it has been damaged, it should be done so the vane "x" fits flat on the nozzle surface and so the stream will enter the window "y" as shown in Figure 5.

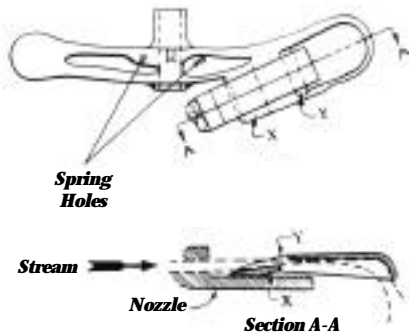

FIGURE 5

A good rule of thumb for adjusting a bent arm is to bend it so that when the arm is at rest, the vane "x" (Figure 5) is just to the left of the nozzle opening when viewed toward the nozzle face with the sprinkler in an upright position.

6 Broken Arm Spring

To replace arm spring, pull the fulcrum pin with a pair of large diagonals or side cutting pliers as shown in Figure 6. The pin is pressed into the body and will come out when pulled as shown in sketch. Cut the spring loose and remove parts.

Feed end of spring through the holes in the arm, as shown in Figure 7, in the following way.

Holding the arm in your hand with the cup part of the spoon facing you,

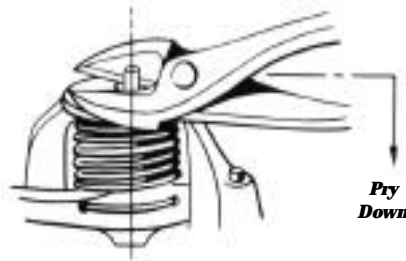

FIGURE 6

and spoon end of arm pointed to your right, feed end of spring into hole on your right (hole nearest spoon) then on through the hole on the left from the back side. The end of the spring is now pointing toward you. Bend over end (approximately 1/4") using needle nose pliers (see Figure 7). The spring wire is normally longer than required. Hold arm with spoon end pointing toward you (looking down on top of arm). Cut off the tag end of the spring at the center line of the arm. Now install arm in body as shown in Figure 7. Drive fulcrum pin into lower hole with hammer. Pull arm around as far back as it will go, away from nozzle and feed upper end of spring into the hole that is farthest from the nozzle. Then feed through the other hole so it extends about 1/8" and bend this extended spring end over sharply to clinch. Check the assembled spring to be sure that the spring end does not rub against the center bearing of the arm or the spring coils when it rotates (see Figure 7).

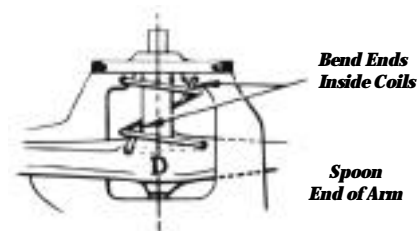

FIGURE 7

Arm weights for some sprinkler models are available from Rain Bird distributors and dealers in order to adjust for proper spring tension. To check spring tension with the arm

weight, hang the weight over the outer lip of the spoon, with the sprinkler held in a sideways position. The weight should deflect the leading edge of the spoon below the nozzle opening but not beyond the hex point on the outside of the nozzle. If an arm weight is not available check the arm tension with that of a new sprinkler or with one that is operating satisfactorily.

If possible, water test sprinkler. Bring pressure up slowly to ensure that arm does not stick in stream. Also, try to hold arm in stream to see if it will come out and oscillate of its own accord.

Use of Arm Weight



FIGURE 8

7 Worn Bearing Washer

Inspect bearing washer (normally black), periodically and replace if worn or damaged. Failure to make needed replacements of these parts will result in damage to the more expensive Bearing Nipple and Sleeve.

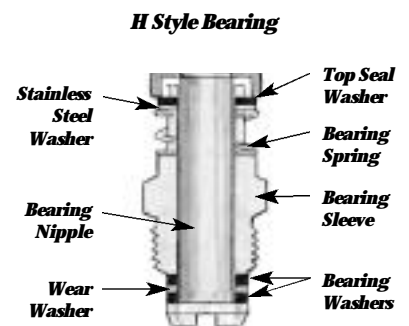
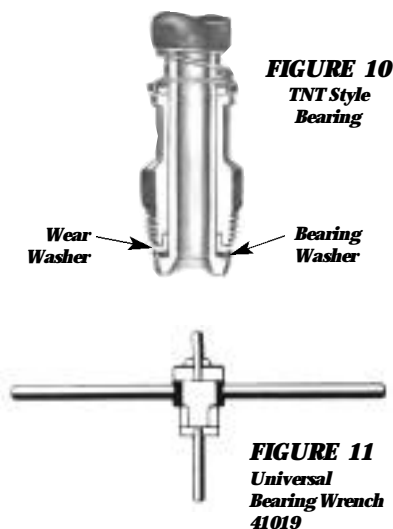

FIGURE 9

8 Worn Wear Washers

The Bearing Sleeve is threaded on the lower end for attachment of the sprinkler to the piping system. The bottom of the lower end of a TNT style bearing (see Figure 10) is machined in such a shape as to fit a T-shaped wear washer. Because of this fit the wear washer should not turn in the Sleeve recess. The bottom of the lower end of the Sleeve is a seat **only**, not a wearing surface, which is also true for the Sleeve in the H style bearing. Note that the H style wear washer is flat and is located differently than the water washer for the TNT style bearing (see Figure 9).

Check the wear washer periodically and replace if worn or damaged. Failure to replace will damage the much more expensive Bearing Nipple and Sleeve.



9 Replacing Bearings

A special wrench (Figure 11) is made to fit all Bearing Nipples and to unscrew them from the body. This wrench should be available at your Rain Bird dealer; however, if you can-

not secure one, a small bar or large screwdriver may be used to unscrew the bearing. Be cautious when placing the sprinkler in a vise, not to squeeze the arm or other extended parts - use the body. Washers that are worn thin from sand and other abrasives in the water should be replaced.

10 Trip Mechanism on Part Circle Models

Model No.25 Sand-Cast Trip Models (bronze color)

The trip spring (Figure 12) is about the only item in this assembly that may need to be replaced after extended use. To reach this spring, pull off the whole assembly after first removing clip. Cut the spring loose from the upper trip casting and replace with a new one in the same position.

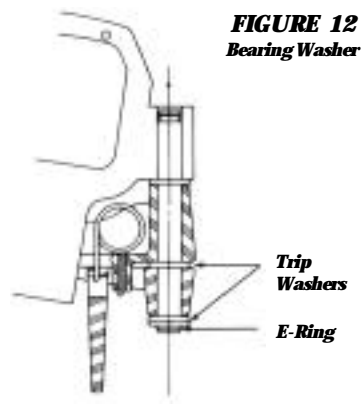

After bending the spring, be sure there is not too much wire left. If there is, cut the end off so that it won't rub against the lower trip casting. The assembly must be put together before it goes on the shaft.

Be sure spacer washers are in place as shown in Figure 12. Some water causes lime deposits, which should be cleaned off. Lime deposits can cause the mechanism to stick after a few years use.

Model No. 25 Powdered Metal Trip Models (yellow color)

Removing and replacing the trip spring for these sprinklers is the same in every respect as for sand cast trip models expect that the spring is held in place by a preform on one leg of the spring. No bending and cutting of the wire is required. The new spring is installed by pressing the spring leg with the preform through the appropriate hole and then following the above instructions for the sand-cast trip models.

Models No. 35 and No. 65D

Although somewhat different in their parts, the operation of these models is basically the same as the No. 25.

11 Setting Part Circle Friction Collars

The purpose of the friction collars is to control the arc of the circle of coverage. On the 25, 35, and 65D, the collars must be moved with the fingers only. Never use pliers in setting these collars. Use of pliers will cause the collars to lose their tension and, after a few settings, they will no longer hold their position.

SPRINKLER REPAIR SERVICE

If, after following the directions in this manual, your Rain Bird sprinkler does not operate properly, take it to your dealer or distributor for servicing. If they do not have the facilities for necessary repairs, contact the factory for the nearest authorized servicing facility.

**DO NOT USE
OIL • GREASE • PIPE DOPE**

**RAIN BIRD SPRINKLERS
ARE WATER LUBRICATED**

Rain Bird Agri-Products Co.
633 W. Foothill Blvd.
Glendora, CA 91741-2469
Phone: (800) 435-5624
Fax: (626) 852-7310

www.rainbird.com

Rain Bird International, Inc.
145 N. Grand Ave.
Glendora, CA 91741-2469
Phone: (626) 963-9311
Fax: (626) 963-4287