

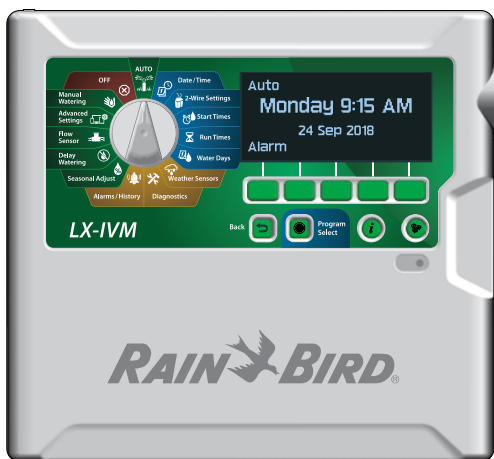

## ESP-LXIVM Controller Troubleshooting Guide



For product manuals, instructional videos and FAQs,  
please visit: [www.rainbird.com/esplxivm](http://www.rainbird.com/esplxivm)

For free professional support for programming and  
troubleshooting, please call: **1-866-544-1406**



## Local Rain Bird Contact Information

Distributor Mgr:

---

Email:

---

Phone:

---

Area Specification Mgr  
Public Agency Manager:

---

Email:

---

Phone:

---

Contractor Account Mgr:

---

Email:

---

Phone:

---

Water Conservation Mgr:

---

Email:

---

Phone:

---

# Contents

Local Rain Bird Contact Information.....	2
<b>Tools.....</b>	<b>4</b>
Recommended.....	4
Useful .....	5
<b>LX-IVM Compatible Valves .....</b>	<b>5</b>
<b>Controller Features .....</b>	<b>6</b>
Front Panel.....	6
2-Wire Settings .....	7
Diagnostics .....	7
Cabinet Components.....	8
<b>Basic Programming .....</b>	<b>9</b>
<b>Troubleshooting Flow Charts .....</b>	<b>10</b>
Getting Started.....	10
2-Wire Mapping .....	11
No Water Days, No Run Times, ... ..	13
Shorted Paths.....	14
Shorted Path (Manual Method) .....	15
Duplicate Address .....	19
Flow Alarm .....	20
Ping Valve / Sensor (Ping Test) .....	22
<b>Field Wiring Diagnostics.....</b>	<b>23</b>
Tools and Equipment .....	23
Total System Milliamp Draw .....	23

Field Wiring Issues .....	23
Broken Wire (Open Circuit) List Not Responding.....	24
Short Circuit .....	25
Ground Fault .....	26
Relay Wiring.....	27
IVM Power Filter Connection.....	29
<b>Controller Diagnostics.....</b>	<b>30</b>
<b>IVM Interface Module .....</b>	<b>37</b>
LED Indicators.....	37
LED Status .....	38
Module Status .....	38
2-Wire Path Status.....	38
Individual Path Status.....	38

## Tools

### Recommended

- MAXI Cable 2-Wire communications cable.
- Rain Bird WC20 splice kits for ALL electrical wiring connections.
- Rain Bird genuine Wire Stripper

For video showing proper wire splice instructions and other installation tips, please visit:

[www.rainbird.com/esplxivm](http://www.rainbird.com/esplxivm)



NOTE: If installing or repairing communications wiring for IQ Software, do not install the communications cables in the same conduit as the 2-Wire path wiring.



**Rain Bird  
Wire Stripper**

## Useful

- **Milliamp Meter**  
Recommended Model: Armada Pro 93
- **As-Built Drawing**  
If you don't have it, make it using a cable locator
- **LX-IVM Troubleshooting Tools**

A list of ESP-LXIVM Controller Troubleshooting Videos can be found here:

<https://www.rainbird.com/esplxivm>



**Milliamp  
Meter**

## LX-IVM Compatible Valves

Videos for ESP-LXIVM compatible valves ,connecting and troubleshooting can be found here:

- **PGA Series**  
<https://www.rainbird.com/products/pga-series>
- **PEB Series**  
<https://www.rainbird.com/products/pebpsb-series>
- **EFB-CP Series**  
<https://www.rainbird.com/products/efb-cp-series>
- **BPE Series**  
<https://www.rainbird.com/products/300-bpes>



NOTE: Rain Bird HV, DV, and JTV Series residential valves are not compatible with IVM-SOL. Use only Rain Bird commercial series valves for ESP-LXIVM installations:



NOTE: Physical interference on any valves can be addressed through "clocking" to avoid being "in-line" with IVM-SOL or removing the component (e.g. Flow Control).

# Controller Features

## Front Panel

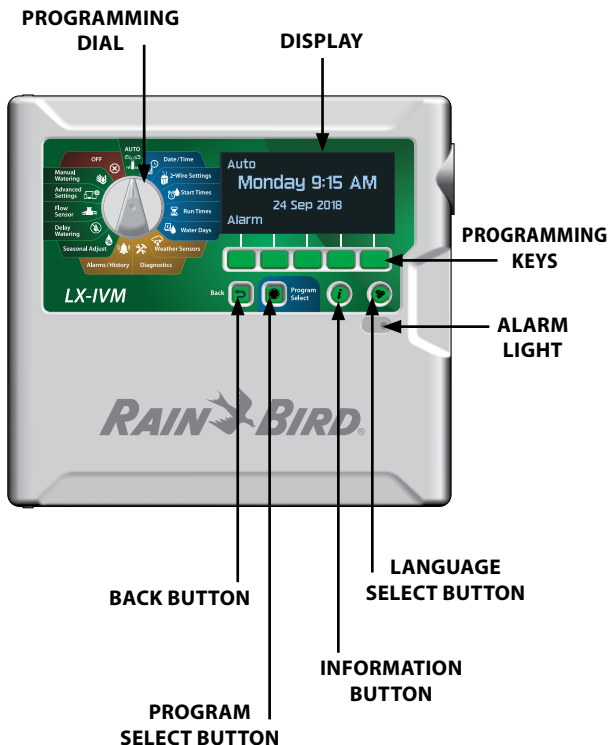

## 2-Wire Settings

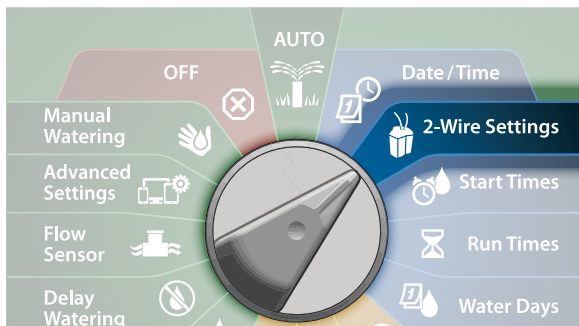

## Diagnostics



# Cabinet Components

## IVM 2-WIRE INTERFACE MODULE

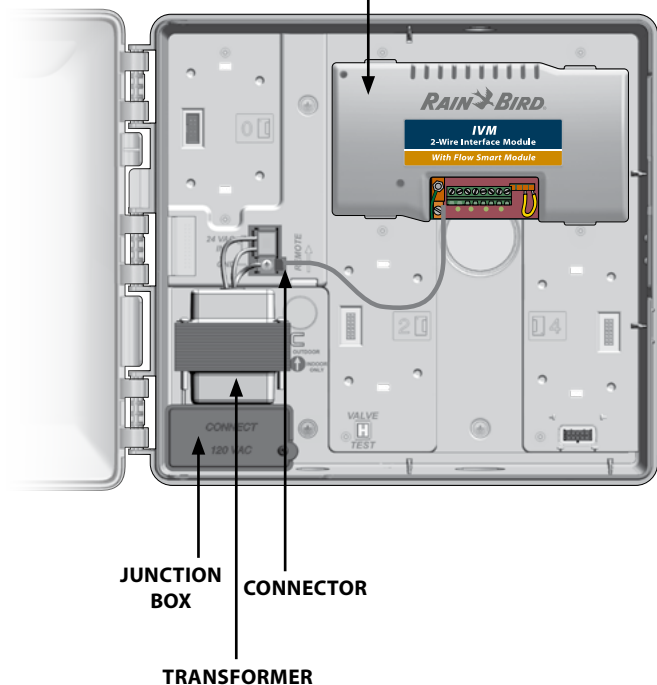



# Basic Programming

The ESP-LXIVM Controller has 2-Wire Settings to help get you started and guide you through each step of the installation and hardware setup process.

It's most effective to use the 2-Wire Settings in the order they appear in the **2-Wire Settings** menu, as follows:

1. Master Valves
2. Weather Sensors (if present)
3. Station Setup
4. Flow Sensors (if present)

## Installation, Programming & Operation Guide

For more information see the LX-IVM Field Device Installation Guide that came with the LX-IVM Controller.

Or download the LX-IVM User Manual at:

[www.rainbird.com/esplxivm](http://www.rainbird.com/esplxivm)

# Troubleshooting Flow Charts

## Getting Started

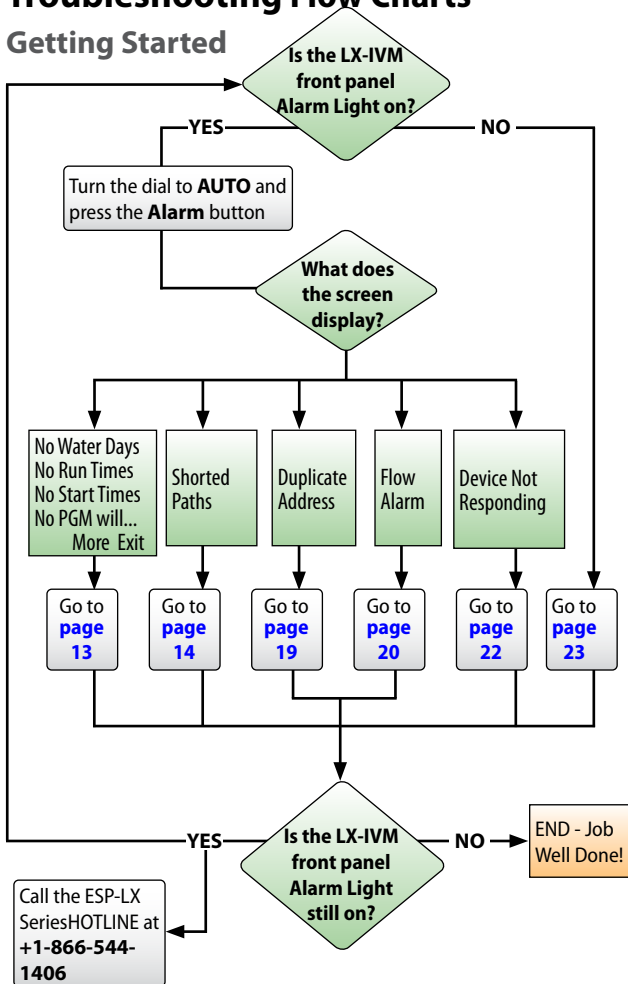

## 2-Wire Mapping

2-Wire Mapping “maps” or records information on the wire-path of any connected IVM devices. A total of 4 wire paths are available in a LX-IVM Controller.



**NOTE:** While this information is helpful for diagnostics, not doing 2-wire mapping WILL NOT affect irrigation functions. But if 2-wire mapping is NOT done, it will raise an alarm at the controller.

*To initiate 2-wire mapping, follow the steps below:*

### Turn the Dial to 2-Wire Settings

1. At the Advanced Station Settings screen, press the Down Arrow key to select 2-Wire Mapping, then press Next.
2. At the 2-Wire Device Mapping screen, press the + and – keys to set the desired hour (from 0 to 23), then press the Right Arrow key.

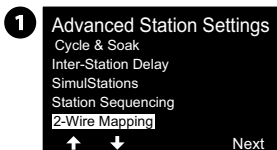

3. Press the + and – keys to set the desired minute (from 1 to 59), then press Next.
4. At the confirmation screen, press Start to begin Device Mapping.



**NOTE:** All irrigation is disrupted during the mapping process.

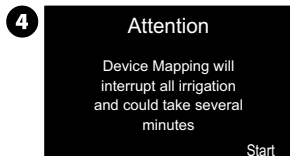

5. A confirmation screen shows the process is set to run.

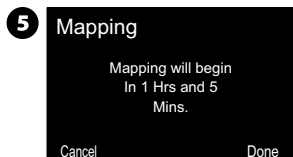

*The following pictures show the List Not responding screen without and with 2-wire mapping done.*

Without 2-wire mapping

A black rectangular screen with white text. The title is 'LIST NOT RESPONDING'. Below it is the date and time 'AT 01/01/18 12 : 00 PM'. A table follows with three columns: 'Type', '#', and 'Path'. The table contains four rows of data. At the bottom are three navigation icons (up, down, refresh) and the word 'Ping'.

Type	#	Path
STA	002	---
STA	004	---
STA	008	---
STA	010	---

With 2-wire mapping

A black rectangular screen with white text. The title is 'LIST NOT RESPONDING'. Below it is the date and time 'AT 01/01/18 12 : 00 PM'. A table follows with three columns: 'Type', '#', and 'Path'. The table contains four rows of data. At the bottom are three navigation icons (up, down, refresh) and the word 'Ping'.

Type	#	Path
STA	002	2
STA	004	2
STA	008	2
STA	010	2

## No Water Days, No Run Times, ...

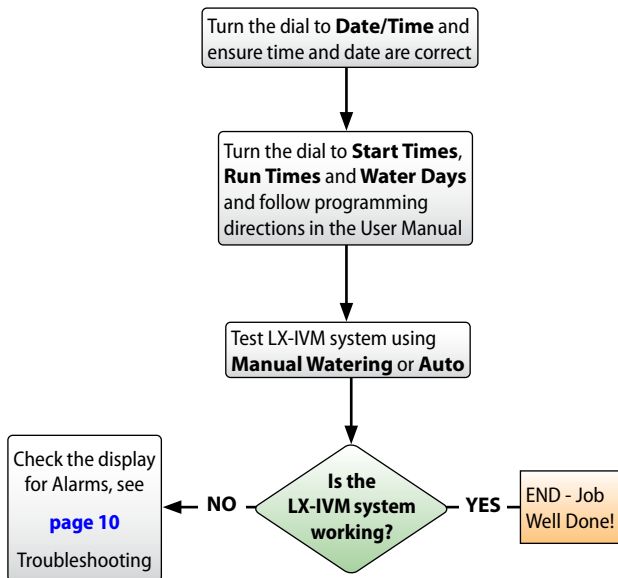

# Shorted Paths

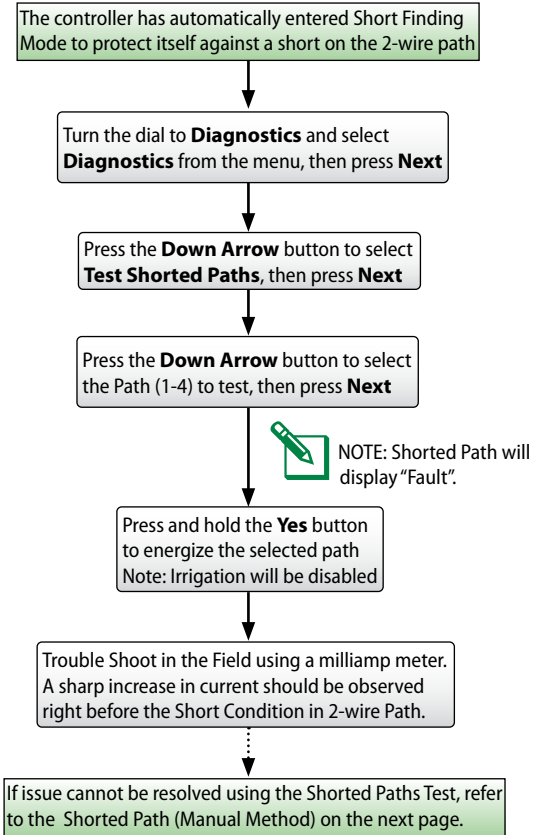

Next Page 

# Shorted Path (Manual Method)

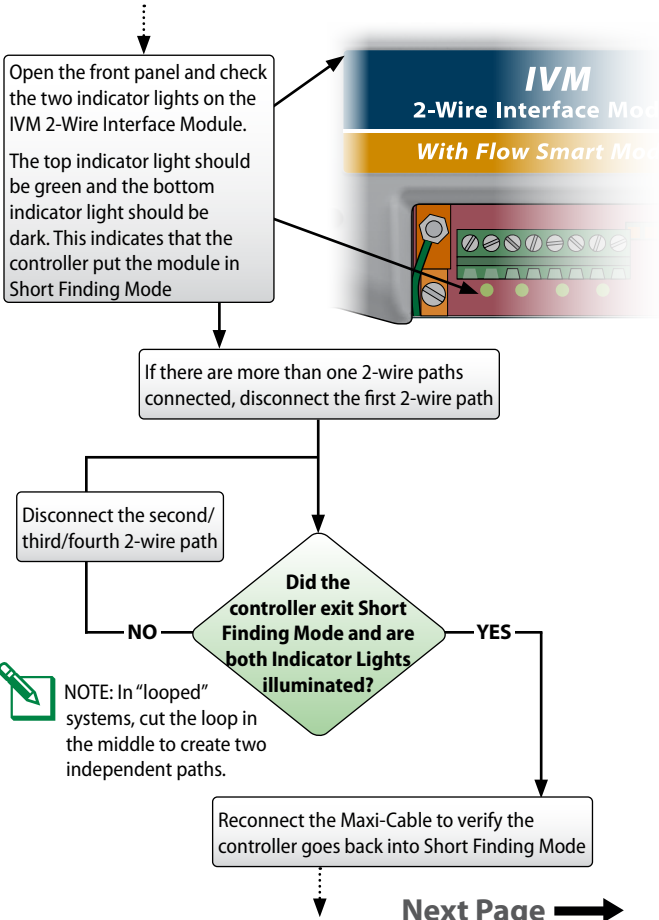

## Shorted Path (Manual Method) cont.

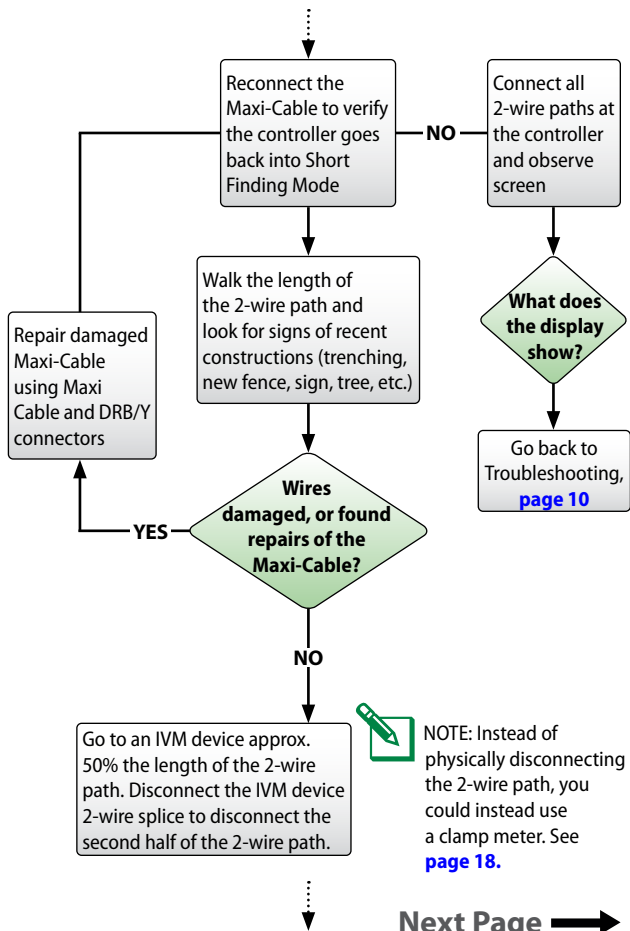



## Shorted Path (Manual Method) cont.

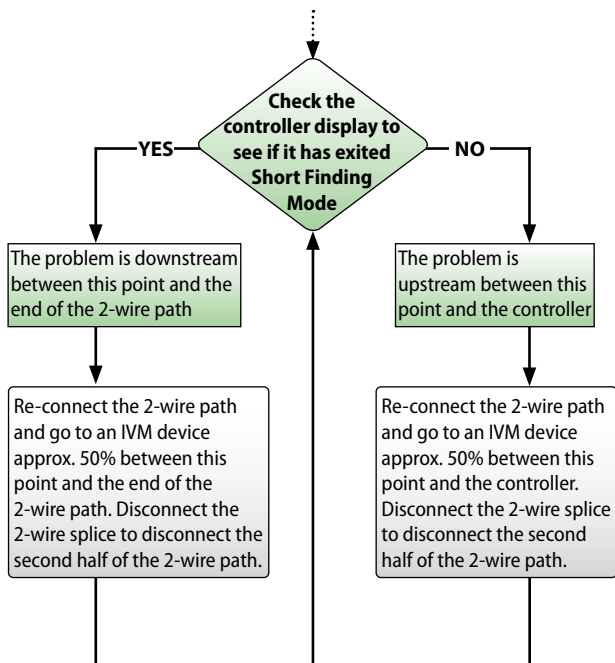

NOTE: Once a small section 2-wire path is identified as having an issue, use "Energize Path for Testing" and Milliamp Meter to track for a sharp increase in test current before the location of the short.

For video instructions on **Automatic Short Finding Mode**, please visit:

[www.rainbird.com/esplxivm](http://www.rainbird.com/esplxivm)

Next Page 

## Shorted Path (Manual Method) cont.

Alternatively you can measure current draw in your system using Diagnostics/ Diagnostics/Controller Output:



NOTE: Before measuring the amperage, calculate the approximate current that the 2-wire path is consuming.

### System Amperage Calculation

	Quantity of IVM-SOL	X	0.67 mA
+	Quantity of IVM-OUT	X	0.67 mA
+	Quantity of other IVM-SEN	X	6 mA
=	Approximate total system amperage in mA		

If there is a mismatch, follow a process similar to [page 10](#) to disconnect 50% of devices and redo calculation above. Continue to disconnect 50% of devices until you identify section of 2-wire Path with issues.



NOTE: Self-healing: Note that IVM Controller tracks the health of the 2-wire Path to see if shorts are resolved and then automatically resumes irrigation. You do not need go back to the Controller to reset or restart.

For video instructions on **Locating a Short on the Two-Wire Path**, please visit: [www.rainbird.com/esplxivm](http://www.rainbird.com/esplxivm)

# Duplicate Address

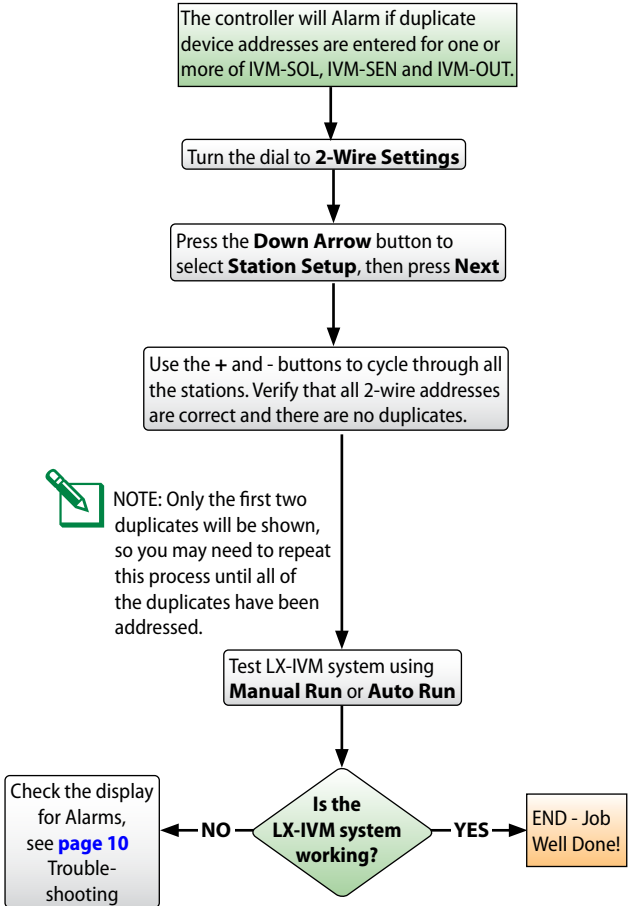

# Flow Alarm

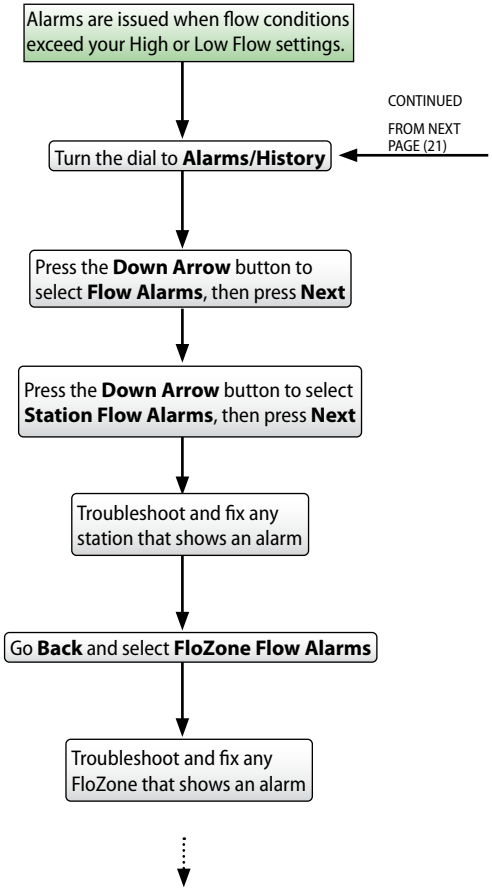

Next Page →

# Flow Alarms cont.

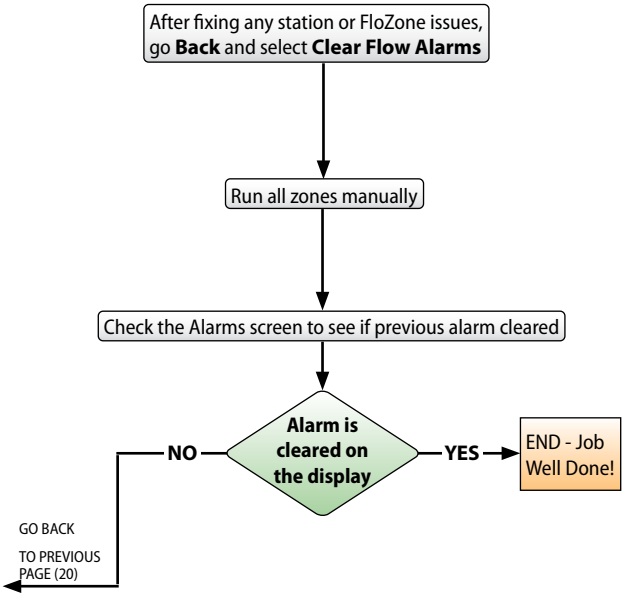

## Ping Valve / Sensor (Ping Test)

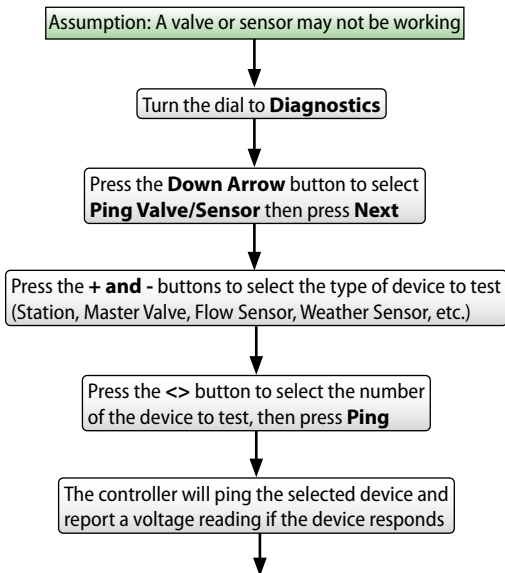

### Interpreting Ping Results

If the device does not respond verify the address and check the wire splices. The voltage reading is a measurement of the charge of the device capacitors.

If the voltage is low, wait a minute then ping again.

If the voltage is still low (below 23 volts), disconnect the device from the 2-wire path and connect directly to an unused wire path at Controller and repeat Ping Test. If the voltage is fine, the issue is with 2-wire path / splicing. If the voltage is still bad, replace the device.

# Field Wiring Diagnostics

The ESP-LXIVM Controller includes multiple diagnostic functions to help you determine the cause of a field wiring issue.

## Tools and Equipment

- An accurate “as-built” showing wire path and 2-wire device locations, the number and type of the 2-wire devices on each wire path, and 2-wire addresses
- Filled out LX-IVM Controller Programming Guide with 2-wire addresses and station/MV/sensor assignments
- A Volt/Ohm Meter (multi-meter) capable of reading 0 to 50 volts AC/DC and resistance from 0 to 1,000,000 Ohms
- A Clamp Meter for measuring AC current with a precision of 1.0 mA (milliamp)
- Wire tracing and fault finding equipment
- Spare system components and tools including: spare IVM-SOL, IVM-SEN device, WC20 Splice Kits and wire strippers

## Total System Milliamp Draw

Before troubleshooting a field wiring issue, calculate the expected total system draw in milliamp (mA). This value can be compared to actual readings during troubleshooting.

- Each IVM-SOL, IVM-OUT draws 0.67mA
- IVM-SEN draws 6 mA
- Add up the total devices of each type for each wire path and calculate the wire path mA draw
- Add the mA for each wire path together for the total system mA draw

## Field Wiring Issues

Field wiring issues are typically caused by a broken wire, a short circuit or a ground fault in the 2-wire path. Refer to the section that best describes the observed symptoms to troubleshoot.

- Broken Wire (Open Circuit)
- Short Circuit
- Ground Fault

**Next Page** 



**NOTE:** A majority of field wiring issues are caused by poor wire splices. Use only WC20 Splice Kits. All splices should be made in splice boxes.



**NOTE:** If the 2-wire path is Looped, disconnect the loop half way out before troubleshooting.

## Broken Wire (Open Circuit) List Not Responding

If there is a broken wire causing an open circuit in the 2-wire path, you will notice one or more stations are not running even though they are programmed to operate. If the system is using flow sensing, you will receive a low (zero) flow alarm for each disconnected 2-wire station.

### Controller Diagnostics

1. Turn the dial to Test All Stations / Check System. Select 2-Wire Diagnostics.
2. Select the List Not Responding. The results will indicate that one or more devices have an open circuit and you will be prompted to Check Wiring. Go to the location of the 2-wire devices that are not responding and check all wire splices.

### 2-Wire Path Diagnostics

1. Note the "List Not Responding" displays and corresponding wire paths. If you notice that all the 2-wire devices that are not responding are in a single leg of the 2-wire path, the open circuit exists between the last working 2-wire device and the first non-working 2-wire device. Check the splices at that location first. Also look for signs of recent construction/digging between the working and non-working 2-wire devices.



**NOTE:** If 2-Wire mapping is not done, the wire path column will not include any information.

2. Turn the controller dial to 2-Wire Diagnostics; Select Short Finding; Turn Short Finding Mode On. Use a Clamp Meter to measure the Amp Draw of the 2-wire path cable conductors at the last working device and the first non-working device. Note any discrepancies in the readings. You must know the number and type of each device downstream to know what the mA reading up should be reading (see the Total System Milliamp Draw section for more information).



## Short Circuit

If there is a short circuit (can be caused by crossed red and black wires) in the 2-wire path, the controller Alarm light will be illuminated and the alarm will inform you the controller has switched to Short Finding Mode. You must fix the short circuit before the controller will switch back to normal irrigation mode.

### 2-Wire Path Diagnostics

1. Disconnect each 2-wire path cable one at a time from the controller IVM 2-Wire Interface Module until the controller exits Short Finding Mode. Reconnect that 2-wire path cable, and if the Short Finding Mode returns you know the short is on that leg of the 2-Wire path.
2. Refer to the as-built to see the location of the 2-wire path. Walk the route of the 2-wire path cable and check for signs of recent construction/digging.
3. Find a device location about half-way down the 2-wire path cable. Disconnect the splices. See if the controller is still in Short Finding Mode. If the Short Finding Mode has cleared, the problem is downstream of this location. If the controller is still in Short Finding Mode, the problem is between this location and the controller. Keep disconnecting segments of the 2-wire path until you isolate the problem.
4. Use a Clamp Meter to measure the Amp Draw of the 2-wire path cable conductors at the last working device and the first non-working device. Note any discrepancy in the readings. You must know the number and type of each device downstream to know what the mA reading up should be reading (see the Total System Milliamp Draw section for more information).
5. The problem may be caused by a device that was damaged by a lightning power surge. The controller will exit Short Finding Mode when the damaged device is disconnected from the 2-wire path.

## Ground Fault

A ground (earth) fault can be caused when a 2-wire path conductor is leaking to ground, possibly due to a bad wire splice, or a nicked or damaged cable. This issue may come and go depending on the soil moisture level. When the soil is very wet the problem will be worse than when the soil is dry.

### Controller Diagnostics

1. Turn dial to Diagnostics / Diagnostics / Control Output.
2. Select Controller. Note the Milliamp (mA) reading. The mA reading will be higher than normal when current is leaking to ground. You must know the number and type of each device in the system to know what the mA reading should be reading (see the Total System Milliamp Draw section for more information).
3. Disconnect each 2-wire path cable one at a time from the controller IVM 2-Wire Interface Module. Recheck the Control Output to isolate which segment of the 2-wire path has the ground fault.
4. Find a device location about half-way down the 2-wire path cable. Disconnect the splices.
5. Check the Control Output to see if the ground fault has been isolated. If the Control Output is normal, the problem is downstream of this location. If the Control Output still shows the ground fault, the problem is between this location and the controller. Keep disconnecting segments of the 2-wire path until you isolate the problem.

### 2-Wire Path Diagnostics

1. Turn the controller dial to Diagnostics / Diagnostics / Test Shorted Path.
2. Use a Clamp Meter to measure the Amp Draw of the 2-wire path cable conductors at various splice locations. Note any discrepancy in the readings. You must know the number and type of each device downstream to know what the mA reading up should be reading (see the Total System Milliamp Draw section for more information).

## Relay Wiring

### For valves without compatible latching solenoids.

IVM-SOL device can be used to connect any Rain Bird Commercial Valve to the LX-IVM Controller. For Non-Rain Bird Valve, use IVM-OUT device in conjunction with a compatible DC latching solenoid to connect to a LX-IVM controller. In the event, a compatible DC latching solenoid is not available, you can use the Rain Bird Pump Start Relay with following modifications to power the AC Solenoid.

1. Connect 110V relay to the + or - 24VAC terminals at the controller's IVM 2-wire Interface Module.



NOTE: Do not connect 2-wire path to the 110V relay terminals.

2. Unplug PSR relay coil wires and output to AC Solenoid.



NOTE: Feed the solenoid wires through bottom of the PSR enclosure.

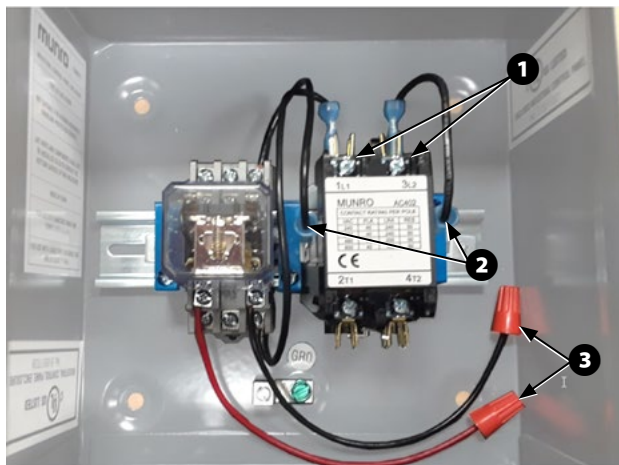

3. Connect the red and white IVM-OUT wire to the red wire of the DC Latching Relay. Connect the black and white IVM-OUT wire to the black wire of the DC Latching Relay.
4. Connect the red IVM-OUT wire to the red wire on the 2-Wire path. Then connect the black IVM-OUT wire to the black wire on the 2-Wire path.

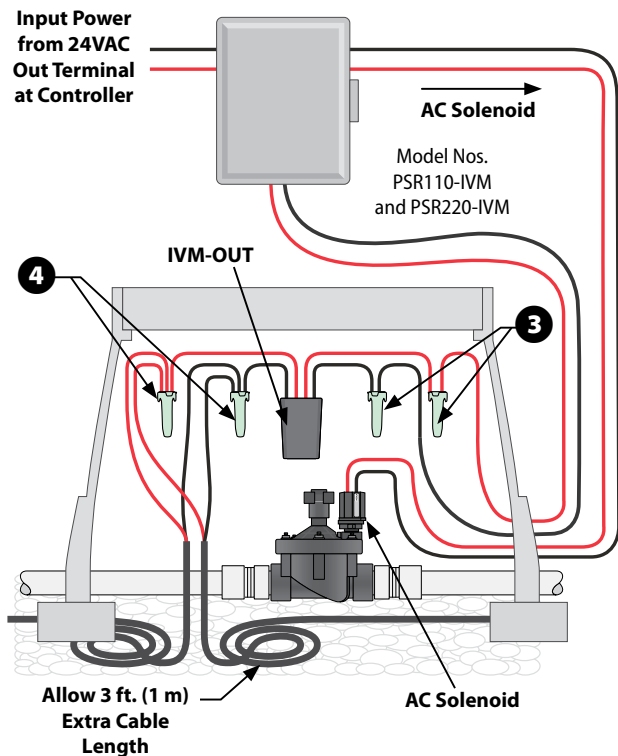

# IVM Power Filter Connection

Electrical Noise in the input power can cause undesirable behavior of the LXIVM Controllers. Sources of Electrical Noise include VFD Pump and other Electrical Equipment.

Rain Bird recommends the GSP-IVM Filter to filter the noise from the input power and ensure normal operation of the Controller. Symptoms can include inconsistent operation of the stations (stations not running as programmed) and inability read flow from a compatible flow sensor.

Rain Bird recommends the following modification to the controller to “filter out” the noise and ensuring normal operations of the Controller.

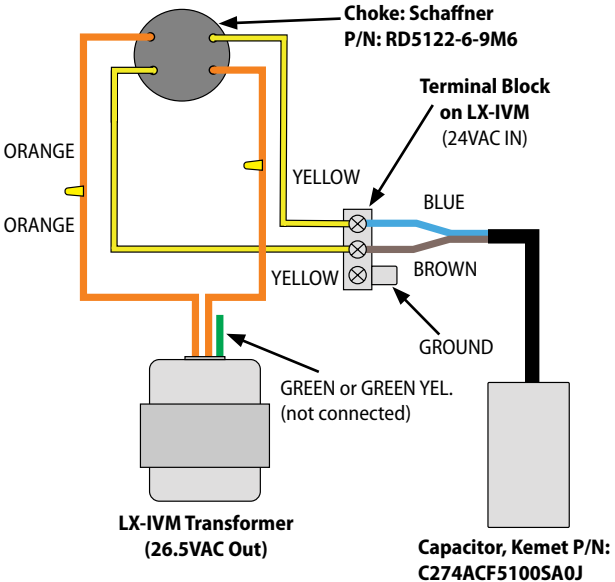

NOTE: IVM Filter Kit can be sourced from Rain Bird GSP via the online services store (link below).

<https://servicesstore.rainbird.com/ivm-filter.html>

# Controller Diagnostics

Use this table to troubleshoot issues using the built-in diagnostic features of the ESP-LXIVM controller.

Category	Issue	Potential Cause	Solution	
Controller Alarms	Red alarm light on the controller front panel is illuminated.	The controller is reporting an alarm condition.	Turn dial to Auto, press the Alarm button, review the alarm conditions, and address the issue(s).	
	Controller alarm; No 2-Wire Module.	The IVM 2-Wire Interface Module is not properly attached to the controller module slots.	Check the upper status light on the IVM 2-Wire Interface Module. It should be solid green if it is properly connected to the controller. Remove and reinstall the module making sure it is fully seated in the module slots.	
	Controller alarm; 2-Wire path Off.	Someone has manually turned the 2-wire path Off.	Turn dial to Off, press the 2-Wire Path button, and turn the 2-wire path On.	
	Controller alarm; Duplicate Device Address.	Duplicate Device addresses have been entered.	Note the duplicate Device Addresses posted in the alarm screen, verify and enter the correct Device addresses.	
	Controller alarm; Short Finding Mode.	2-wire path is shorted and the controller has automatically switched to the Short Finding Mode. The lower left status light on the controller is dark.		Disconnect the 2-wire cables from the IVM 2-Wire Interface Module one at a time until the alarm condition clears. The lower left status light on the controller will alternate between red and green when the wire path with the short is removed.
				Trace the path of this 2-wire cable and look for source of issue (disturbed soil, new tree or fence post, etc).
Disconnect the 2-wire cable halfway between the controller and end of cable and check to see if the alarm clears to help identify short location on the cable.				
Use a volt/ohm and clamp meter to identify which devices are receiving power.				
		Fix the short and check that the alarm is cleared.		
Controller alarm; No Device Addresses.	Device addresses have not been entered for any stations.	Turn dial to 2-Wire Settings / Station Setup. Enter the address (see label on each Device) for each station. Addresses are also required for Master Valves, Weather Sensors and Flow Sensor.		

Category	Issue	Potential Cause	Solution
Controller Alarms	Controller alarm; Zero Learned Flow.	The Learn Flow Utility has recorded a zero (0) flow rate for one or more station.	Turn dial to Flow Sensor / Set Flow Rates / View Flow Rates / View Station Rates. Check for stations that have a 0 flow rate and are labeled Learned.
			<ul style="list-style-type: none"> <li>• If all stations have learned a 0 flow check flow sensor/ input connections, Flow Sensor configuration, FloZone assignments, etc.</li> <li>• If only one or a few stations have learned a 0 flow rate check the valve operation (flow control stem position, solenoid, wiring, etc.).</li> <li>• If just small flow rate valves/stations (like drip zones) have learned a 0 flow rate the flow sensor may be too large for the lower flow rates. Check the product technical specs for the minimum flow rate of the flow sensor.</li> </ul>
Controller alarm; Flow Alarm.	FloWatch (flow sensing utility) has detected a high or low flow condition.		Turn dial to Alarms / History / Flow Alarms, and review the posted Station and/or FloZone (mainline) flow alarms. Note the station(s) or FloZone(s) that were identified. If you configured FloWatch to Diagnose & Eliminate or Alarm & Shut Down, the problem station(s) or FloZone(s) will be quarantined. Clear the Flow Alarms and test the system.
			<ul style="list-style-type: none"> <li>• Station flow alarms – Manually turn on the station. Turn dial to Flow Sensor / View Current Flow. The current and expected flow rates will be listed. Check the valve &amp; sprinklers to identify the issue and correct it. If sprinklers or nozzles have been replaced, relearn the station flow rate.</li> </ul>
			<ul style="list-style-type: none"> <li>• FloZone alarms - Manually start a program. Turn dial to Flow Sensor, View Current Flow. The current and expected flow rates will be listed. Check the water source(s) and mainline to identify the issues and correct it.</li> <li>• If FloZone high flow alarms are being triggered by manual watering (QCV, manually bleeding valves, etc.) consider using the MV Water Window located under the Manual Watering dial position. Configure window open and close times, days of the week, MV(s) you want open, and the expected additional flow rate to allow for the manual watering.</li> </ul>

Category	Issue	Potential Cause	Solution
Controller Alarms	Controller alarm; Invalid Module Config.	A non-compatible module has been inserted into one of the controller module slots.	Remove any recently added modules, one at a time, until the alarm condition clears.
			<ul style="list-style-type: none"> <li>ESP-LXME/-LXMEF Controller 4-, 8-, &amp; 12-Station Modules, FSM Flow Smart Modules, M50 and SM75 Modules are not compatible.</li> </ul>
	Controller alarm; No PGM will Auto Run.	Incomplete programming.	Turn dial to Diagnostics / Confirm Programs / Program Summary. Missing programming parameters are identified by an N. For programs to automatically run you need to program Start Days, Start Times, and Station Run Times.
	Controller Alarm; No Power – Irrigation Functions are Disabled.	No primary power to the controller transformer	Check the power input to the controller transformer. The display is being powered by the 9v backup battery.
Front panel ribbon cable is disconnected		Check both ends of the ribbon cable to make sure it is firmly connected to the backplane and front panel.	
2-Wire Path Issues	Communication with 2-wire devices is intermittent.	2-wire cable or splices are leaking to ground or between conductors.	Turn dial to Diagnostics / Control Output. The controller voltage output and 2-wire path milliamp draw will be displayed.
			<ul style="list-style-type: none"> <li>If there are no issues you will see Current Limit OK, Current Overload OK.</li> </ul>
			<ul style="list-style-type: none"> <li>If the 2-wire cable leaks are drawing a high amount of current you will see Current Limit Not OK, Current Overload OK. Use the troubleshooting tips above to find and fix the 2-wire cable/splice issues.</li> <li>If the 2-wire cable leaks are drawing a high amount of current you will see Current Limit Not OK, Current Overload Not OK. The controller will have automatically switched to Fault Finding Mode. Use the troubleshooting tips above to find and fix the 2-wire cable/splice issues.</li> </ul>
Controller loses connection to 2-wire devices after a heavy irrigation or rainfall event.	Communication signal and power leaks to ground.	<ul style="list-style-type: none"> <li>Single-jacketed cable and/or incorrect wires splices were used. When incorrect cable/splices become submerged it can create leakage to ground. Double-jacketed 14-2UF Maxi 2-Wire Cable and WC20 Splice Kits are required.</li> </ul>	



Category	Issue	Potential Cause	Solution
IVM-SEN/ Sensor	The controller is not getting data from a flow or weather sensor connected to a IVM-SEN/ Sensor on the 2-wire path.	Sensor wiring polarity is reversed.	Many sensor including flow sensors require wires to be connected with correct polarity (+ / -). If the sensor has colored or labeled wires, connect as follows: <ul style="list-style-type: none"> <li>• Sensor red (+) wire to the IVM-SEN Sensor red wire.</li> <li>• Sensor black (-) wire to the IVM-SEN Sensor black wire.</li> </ul>
		Flow sensor output pulse rate is not compatible with the LX-IVM Controller.	The LX-IVM Controller requires a minimum input of 2 pulses per 10 seconds for the smallest station flow rate. Pulse rates of less than 2 pulses per 10 seconds will not be registered. Change to a compatible flow sensor.
		Weather sensor type is not compatible.	The LX-IVM Controller is not compatible with 4-20 mA or 0-5V weather sensors (discrete switched sensors only).
Programs	Programs are running at random times.	Multiple start times have been programmed unintentionally.	Turn dial to Diagnostics / Confirm Programs / Review Program. Review each program using the Program Button to select the program. Check for multiple start times on an individual program. In some cases users' mix-up start times and stations and can inadvertently program the system to start multiple times per day.
		Water Windows have been configured so programs are paused and resume later.	Turn dial to Delay Watering / Water Window. Use the Programs Button to select a program 1 - 40. Water Windows control the hours of the day a program is allowed to operate. If a program starts outside a Water Window it is paused until the window opens. If the program is still running when the Water Window closes the program is paused and will automatically start the next time the window opens. Adjust the Water Window open and close times to allow the program to complete.
Station Sequencing	Stations are not running in station number sequence	Station Sequencing set to Sequence by Station Priority	The LX-IVM offers 2 station sequencing modes: <ul style="list-style-type: none"> <li>• Sequence by Station Numbers (default) – Station selection criteria: a) Non-Irrigation Priority; b) Station number low to high; c) Program assignment 1 - 40.</li> <li>• Sequence by Station Priority (automatically used if FloManager is On) – Station selection criteria: a) Station Priority Non-Irrigation, High, Medium, Low; b) Station Run Time longest to shortest; c) Station number low to high; d) Program Assignment 1 - 40.</li> </ul> To change Station Sequencing mode turn dial to 2-Wire Settings / Advanced / Station Sequencing. Use the +/- softkeys to change the selection.

Category	Issue	Potential Cause	Solution
Station Valves	A station valve is not operating.	Valve is manually closed or solenoid is damaged.	Turn dial to Manual Watering / Start Station. Select the station making sure it has a run time and press run. Check to see if the valve is operating and if it isn't, address the valve issue.
		Station does not have run time for a program with start days and a start time.	Turn dial to Diagnostics / Confirm Program / Station Run Time. Note which programs the station has run times programmed. Use Program Summary to make sure that program has start days and start times.
Station Valves	A station valve is not operating.	IVM-SOL or valve wires are not spliced correctly.	Turn dial to Diagnostics / Diagnostics / Ping List not Responding. If the ping test fails check the device and valve wire splices and repeat the ping test.
		Incorrect address.	Check the address of the station (label on the IVM device that is connected to the valve) and verify the address is entered correctly. Turn dial to 2-wire Setting / Station Setup to access Station Address.
		Incorrect Valve Type	Turn Dial to 2-wire Setting / Station Setup / Valve Types. Valve types configure the decoder inrush amps and duration for opening a valve solenoid. The LX-IVM Valve Types are preconfigured for Rain Bird commercial valve models. Information for configuring Valve Types to work with other valves can be found in the controller manual. Note: Rain Bird residential valves (DV, JTV, HV) are not compatible with the LX-IVM system or IVM-SOL.
		2-wire path from the controller is not connected to this area.	Ping other valves on the same 2-wire path leg. If these pings are also unsuccessful, check for an open wire connections on the 2-wire path.
Master Valves	The Master Valve will not open when stations are operating.	MV is assigned to a different FloZone than the stations.	Turn dial to 2-Wire Settings / Master Valves. Press Next to advance to FloZone (FZ) Setup screen. MV needs to be assigned to the same FloZone as the stations that receive water from this water source.
		MV is Normally Open but has been configured as a Normally Closed MV.	If the MV valve is Normally Open (powered to close) it needs to be configured as Normally Open. Turn dial to 2Wire Settings / MV Setup. Change MV from Normally Closed (default) to Normally Open.
		Station not configured to open Master Valve.	Go to 2-Wire Settings / Station Setup to make sure the station is configured as requiring a Master Valve.
		MV Address is incorrect.	Check the address of the MV (label on the IVM device that is connected to the MV) and verify the address is entered correctly. Turn dial to Setup Wizards / Master Valves to access MV Address.

Category	Issue	Potential Cause	Solution
Master Valves	The Master Valve will not open when stations are operating.	2-wire device or valve wires are not spliced correctly.	Turn dial to Diagnostics / Diagnostics / Select Ping MV and ping the MV address. If the ping test fails  check the decoder and valve wire splices and repeat the ping test.
		IVM-Device is not functioning or damaged.	Turn dial to Diagnostics / Diagnostics / Ping Valve or Sensor, then ping the MV address. If the ping test fails swap the device, enter the new address and repeat the ping test.
IVM 2-Wire Interface Module	No output from the module.	Fuses in the module have blown due to short or secondary power connected to the 2-wire path.	Find the source of the short or power connected to the 2-wire path and address the problem. A replacement 2-wire Module is available for purchase.
		Module is in Automatic Short Finding Mode due to short or secondary power connected to the 2-wire path.	Find the source of the short or power connected to the 2-wire path and address the problem.
Pump Start Relays	The controller cannot close the pump start relay that is connected to a IVM-OUT.	Amp draw of the pump start relay is more than the Device can provide.	Use a Rain Bird PSR-Series Pump Start Relay that incorporates an ice-cube relay, double relay system. You can also add an ice-cube relay to the existing pump start relay. Contact Rain Bird Technical Services or Global Support Plan for relay model and wiring diagram.
Controller LCD Display	The controller display is either too light or too dark.	The display contrast needs to be adjusted.	Turn dial to Off, press Contrast +/- buttons to adjust display contrast.
	Controller display is blank.	Controller LCD display is damaged.	Plug in a 9V battery into the battery slot on the back of the controller front panel. If information is now visible on the display it is not damaged and working correctly. See other potential causes. If no information is displayed, remove the 2-wire module. If the alarm light on the front panel turns on after 1 minute but no information is in the display, the LCD is damaged and the front panel should be replaced. A replacement panel is available for purchase.
		Primary power to the controller has been lost or turned off.	This can be verified by checking the status lights on the 2-wire module. If both status lights on the module are dark the primary power is likely off. Find primary power source to the controller and turn it on. If the power breaker is tripped or fuse is blown, find source of problem, fix the issue, and turn the power back on.
		Controller ribbon cable is not connected or damaged.	Check to make sure the ribbon cable is securely connected to both the controller backplane and the front panel. If the cable has broken wires or connectors, replace it.

Category	Issue	Potential Cause	Solution
Simul Stations (Simultaneous Station Operation)	Too many or too few stations are operating simultaneously when program(s) operate.	LX-IVM (Controller) SimulStations are configured incorrectly.	Turn dial to 2-wire Setting / Advanced / SimulStations. Select LX-IVM SimulStations and adjust the maximum number of simultaneous irrigation stations you want to allow to operate across all programs at any time. Non- Irrigation SimulStations control stations with Non-Irr Priority.
		PGM (Program) SimulStations are configured incorrectly.	Turn dial to 2-wire Setting / Advanced SimulStations. Select PGM SimulStations and adjust the maximum number of simultaneous irrigation stations you want to allow to operate simultaneously within the currently selected program. Move the Program Button to select the other programs 1 - 40.
Weather Sensors	Weather sensor is not preventing controller manual operation.	This is by design.	Manual station, program or test program operation (from the front panel or a remote) is allowed regardless of the weather sensor state. To see the current state of a weather sensor, turn the dial to Weather Sensors. The status of each sensor is displayed.
	Wireless weather sensor is not providing input to the controller.	Sensor receiver is not wired to the controller module correctly.	The IVM 2-Wire Interface Module includes 4 terminals for wireless weather sensor connections. Wiring connections should be made as follows: <ul style="list-style-type: none"> <li>• Sensor receiver power wires to + and – terminals.</li> <li>• Sensor receiver sensor wires to Sen and C terminals.</li> </ul>
Controller Knock-outs	I am having trouble removing the knock-outs on the ESP-LX Series Controller plastic cabinet.	Unlike knock-outs on a metal enclosure, these plastic knock-outs are designed to be removed by applying force to the center at the dimple.	Prior to installing the cabinet, place on a flat surface with the knock-out facing up. Locate the dimple in the center of the knock-out you wish to remove. Place the tip of a large Phillips screwdriver in the dimple. Use a rubber or wooden mallet to firmly strike the top of the screwdriver. The knock-out should pop out in a single piece. If it breaks, use pliers to remove the pieces. Do not use a flat-bladed screwdriver around the outside of the knock-out as this could crack the case.

# IVM Interface Module

This section explains the LED Status indicators on the IVM 2-Wire Interface Module.

## LED Indicators

**MODULE STATUS**

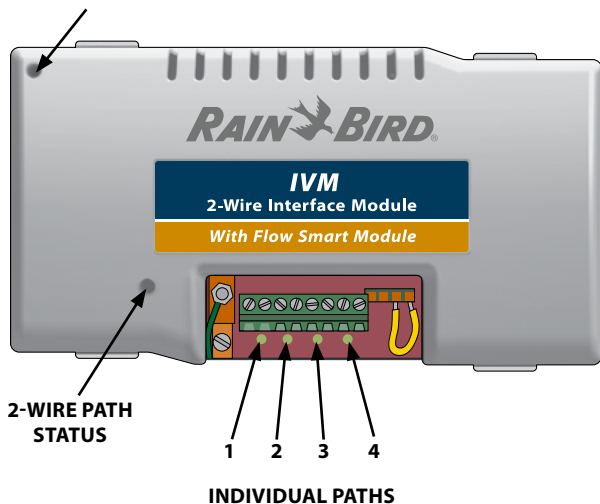

# LED Status

## Module Status

Module State	Description	LED Light
POWER OFF	Power off or module is held in reset.	Dark
POWER UP	During initial power up or after reset	Briefly lights GREEN to indicate power applied
ENUMERATION or ERROR	Waiting for enumeration.	Flashing RED
CONFIGURATION	After enumeration, while receiving device addresses and configuration from the front panel	Flashing ORANGE
NORMAL	After configuration download is complete (from front panel and setting all IVM-SEN to either flow or weather). This is the Normal up and running state.	Solid GREEN
SHORT ADDRESS CONFIGURATION	During the Normal state, there are devices in the field that have not yet been programmed with short addresses. All other normal communication to field devices still function while in this state.	Flashing GREEN

## 2-Wire Path Status

Module State	Description	LED Light
POWER OFF	Power off or module is held in reset.	Dark
2-wire ON	Normal state with 2-Wire path powered on.	Blinking GREEN
2-wire OFF	2-Wire path powered down.	Dark

## Individual Path Status

Module State	Description	LED Light
POWER OFF	Power off or module is held in reset.	Dark
Individual path enabled	Path connected (2-Wire path may be on or off).	Solid GREEN
Individual path disabled	Path disconnected (2-wire path may be on or off).	Solid RED



## **Rain Bird Corporation**

6991 E. Southpoint Road  
Tucson, AZ 85756  
Phone: (520) 741-6100

### **Questions?**

Call the Rain Bird Professional Support Line at

**+1-866-544-1406**

or else visit our web site at  
[www.rainbird.com/esplxseries](http://www.rainbird.com/esplxseries)

### **Rain Bird Rewards:**

[www.rainbird.com/rewards](http://www.rainbird.com/rewards)  
Phone - 1-888-370-1814

### **Global Service Plan:**

[www.rainbird.com/gsp](http://www.rainbird.com/gsp)  
Phone: 866-GSP-XPRT (477-9778)

®Registered trademark of Rain Bird Corporation

©2020 Rain Bird Corporation 23DE20